

ELOTECH
INDUSTRIELELEKTRONIK GMBH

R1140 : The Temperature Controller with Data-Interface

- RS 232-C, RS 485, 0/20mA
- Profibus DP
- CANopen



R1140

DIN-Format: 48x96mm, 1/8-DIN
Installation depth: 122mm

OPERATING MANUAL

1. Contents

1. Contents	2
2. Type Code	2
3. Technical Data	3
4. R1140-10: Connection diagram	4
5. Display and Keyboard.....	6
6. Operating Levels	7
6.1 Configuration Level	8
6.2 Parameter Level.....	15
6.3 Operating Level.....	18
7. CANopen, general.....	20
8. Profibus DP, general	20
9. Error Displays.....	21
10. Installation Instructions	21
11. Parameter Adjustments.....	22

**Please read this operating manual carefully before starting up.
Observe the installation and connecting instructions.
Take care to the separat interface- and data transmission descriptions.
See: www.elotech.de**

Disclaimer of liability

We have checked the contents of the document for conformity with the hardware and software described. Nevertheless, we are unable to preclude the possibility of deviations so that we are unable to assume warranty for full compliance. The information given in the publication is, however, reviewed regularly. Necessary amendments are incorporated in the following editions. We would be pleased to receive any improvement proposals which you may have.

2. Type Code

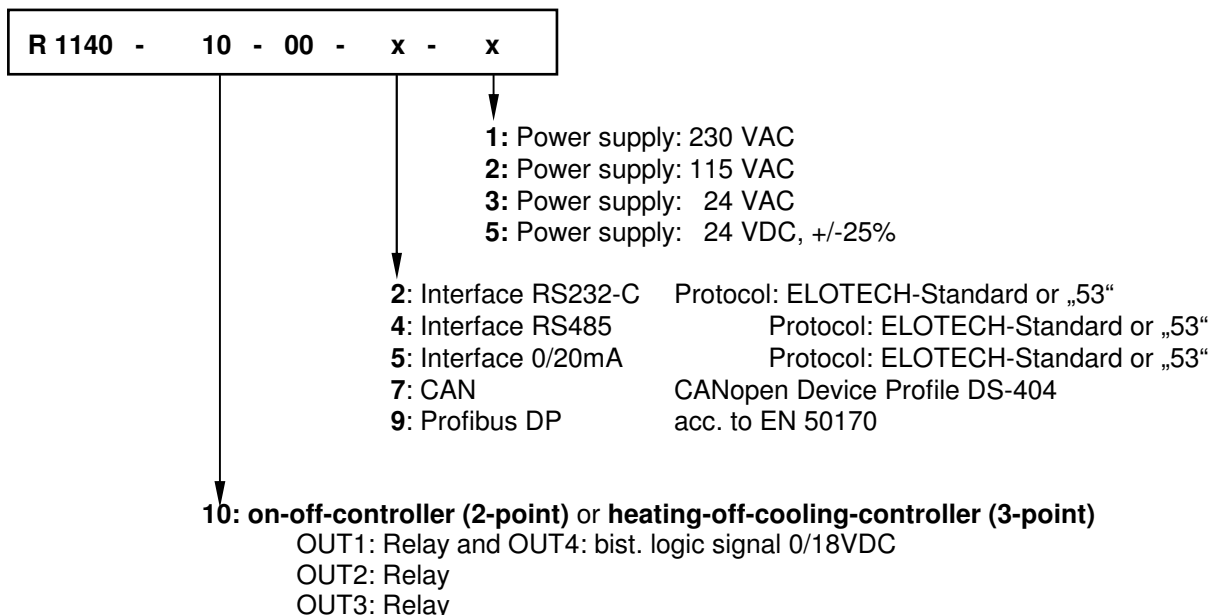

3. Technical Data

Input Thermocouple:	Built-in internal compensation point and protection against sensor breakage and incorrect polarity. Re-calibration not required for a line resistance of up to 50 Ohms. Calibration accuracy: $\leq 0,25\%$
Input RTD:	Built-in protection against sensor breakage and short circuit. Max. permissible line resistance by 3-wire connection: 80 Ohms Sensor current: $\leq 0,5 \text{ mA}$ Calibration accuracy: $\leq 0,2 \%$
Input 0/4-20mA:	Load max. 10 Ohm
Linear error:	$\leq 0,2 \%$
Influence of the ambient temperature:	$\leq 0,01 \%$ / K
External contacts (K1-K3):	Ext. potential-free contact, switching voltage appr. 24 VDC, max. 1mA.
Control outputs:	- Relay (UR appr.), max. 250 VAC, max. 3 A (cos-phi = 1) - Logic / bist. voltage signal, 0/18 V dc, max. 10 mA, short-circuit proof
Alarm output: -OUT 2:	- Relay (UR appr.), max. 250 Vac, max. 3 A (cos-phi = 1). Only for 2-point-controller configuration.
-OUT 3:	- Relay (UR appr.), max. 250 Vac, max. 3 A (cos-phi = 1).
7-Segment-Display:	Process: 10 mm red, Set: 10 mm red
Data protection:	EAROM
CE-Mark	Tested according to 2004/108/EC; EN 61326-1; industrial areas Electr. safety: EN 61010-1
Power supply:	Standard: 230 VAC; $\pm 10 \%$, 48-62 Hz, 3,5VA. (Others: see Type Code).
Connections:	Screw terminals (UR appr.). Protection mode IP 20 (DIN 40050), Insulation class C.
Permissible operating conditions:	Operating temperature: 0...50 °C / 32...122 °F Storage temperature: -30...70 °C / -22...158 °F Climate class: KWF DIN 40040; Equivalent to annual average max. 75 % rel. humidity. No condensation.
Casing:	Format: 48 x 96 mm (DIN 43700). Installation depth 122 mm Panel cutout: 45 +0,6 mm x 92 +0,8 mm Material: Noryl, self-extinguishing, non-drip, UL 94-V1 Protection mode: IP 20 (DIN 40050), IP 50 front side
Weight:	app. 420g

Subject to technical improvements!

4. R1140-10: Connection diagram

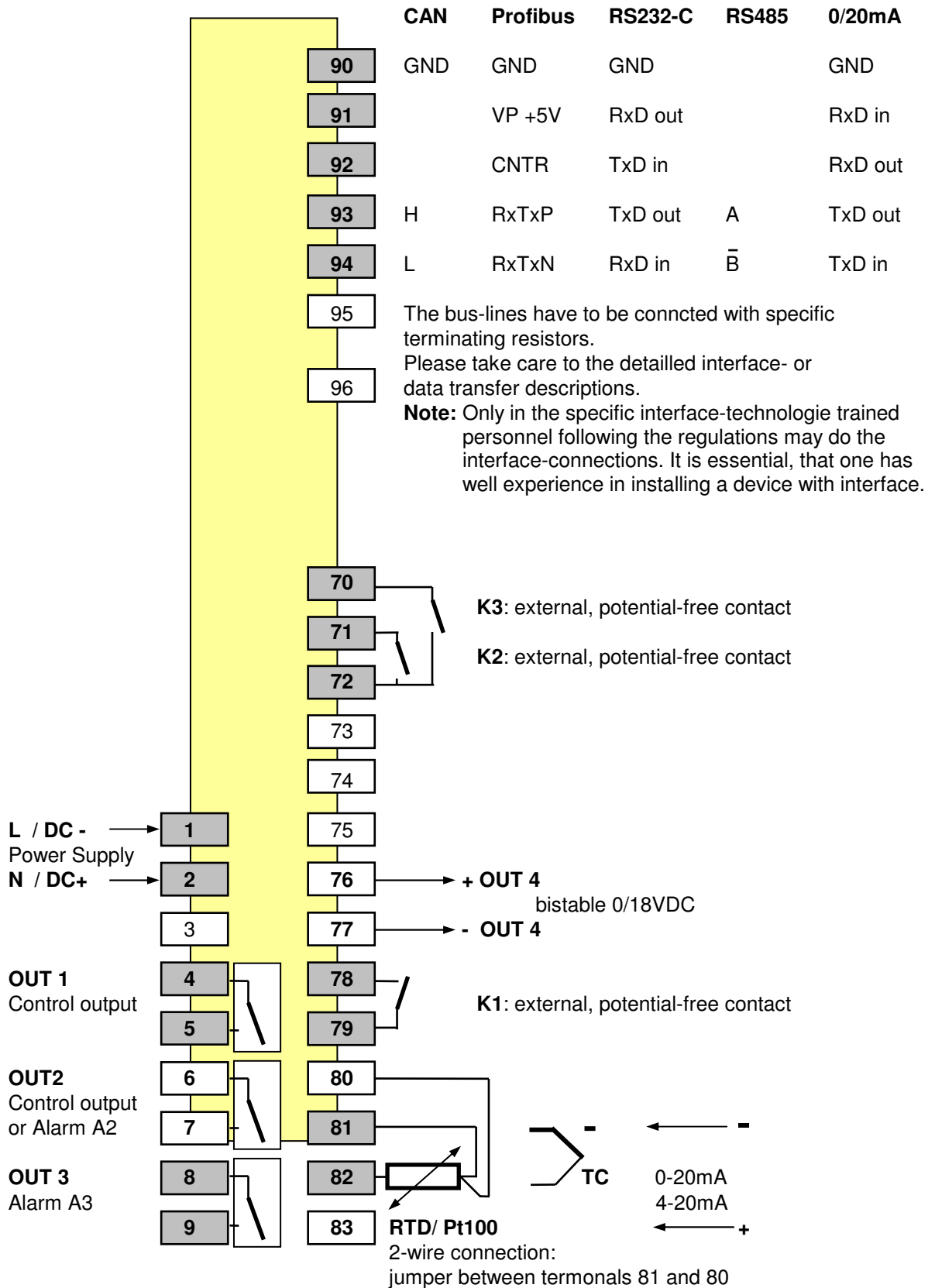

It is not permitted to connect the grounds of the sensor- and bist. voltage-outputs with each other.

Control- and Alarm Outputs:

OUT1 = Control output	2-point-controller: 3-point-controller:	"Heating" e.g. „Cooling“ „Heating“
OUT2 = Control output or alarm output	3-point-controller: 2-point-controller:	„Cooling“ Alarm 2
OUT3 = Alarm Output	Alarm 3	
OUT4 = Control-output	Logic output (0/18VDC) instead of output OUT1 or output OUT2 Please take attention at Configuration level: parameter „Out4“	

Functions of the external, potential-free contacts K1 – K3:

Contact K1:

Setpoint Controlling

K1: open = Setpoint 1 (SP1) valid
K1: closed = Setpoint 2 (SP2) valid

Contact K2:

Adjustment lock (LOC)

K2: open = Adjustment lock only via the selected "software code"
K2: closed = Adjustment locked (according to the chosen software code)

Contact K3:

CAN - Interface:

K3: open = CAN: „operational“. Operation only with CANopen protocol.
K3: closed = CAN: „operational“ always active.
„K3“ must be closed, if the instrument is equipped with a CAN-interface but not used.

5. Display and Keyboard



Display PROCESS:
Standard: **actual process value**

Display SET:
Standard: **setpoint value**

LED 1: OUT1, control output „on“
LED 2: OUT2, control output „on“ or alarm output A2
LED 3: OUT3, alarm output A3

LED SP2: Setpoint 2 active

P

1. Parameter preselection
2. Sets the parameter back to the originally stored value.
Any alterations made to the parameters, that are not confirmed (E-key) within 30 seconds, will not be accepted and the parameter will return to its originally stored value.



Adjustment of chosen parameter (e.g. setpoint) to higher or lower values.
E.g. setpoint adjustment.



Short operation: single-step adjustment
Longer operation: quick-scanning

When the parameter adjustments have been altered but not entered, the display will flash bright/dark. In this case, please press key „E“.

E

Confirmation and storage of the pre-selected values (enter).
The display will shortly show a light chain as a control of this function.
To return to the process- and setpoint-display: press „E“ appr. 2 sec..

6. Operating Levels

The operation of the controller is divided into three levels.

Appr. two seconds after switching on the unit, the controller will automatically be in the operating level.

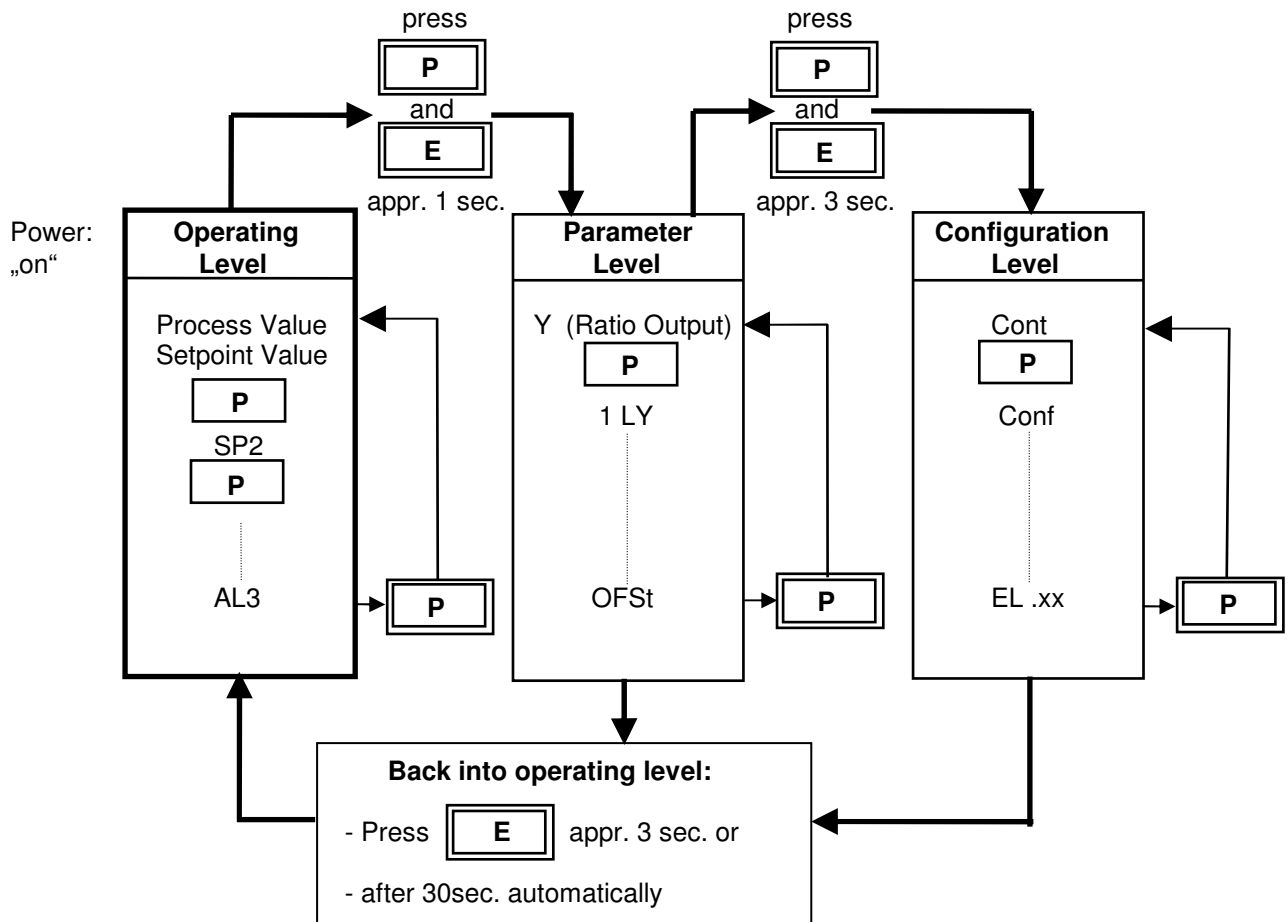

Operating level:

Process- and setpoint value will be displayed simultaneously.

Within the operating level the setpoints and the alarm values can be adjusted by pressing the "▲"/"▼" - keys. Every adjustment has to be quit by pressing the „E“ - key.

All parameters within the operating level can, in succession, be displayed by pressing the „P“ - key and adjusted by pressing the "▲"/"▼" - keys.

To switch off the controller function (stand-by operation), the parameter „Cont“ has to be programmed to „OFF“. After operating the „P“-key it is possible to preadjust the setpoint „SP1“.

Parameter level:

Enter this level by pressing the „P“ and „E“-key appr. 1 sec. simultaneously.

Within the parameter level the values are adjusted to suit the control behaviour to the individual process. Leave this level by pressing key „E“ appr. 3 sec..

Configuration level:

Enter this level by pressing the „P“ and „E“-key appr. 3 sec. simultaneously.

In the configuration level the controller type, sensor type, the sensor range, the alarm behaviour and the output type can be pre-selected.

This primary information has to be entered before taking the controller into operation.

The display of each single parameter within the parameter and configuration levels, and their adjustment, are made in the same way as within the operating level.

After either pressing the „E“ - key for approx. 3 seconds, or waiting for a period of approx. 30 seconds, the unit will automatically return to the operating level (display of process value and setpoint).

6.1 Configuration Level

(Press „P“ and „E“-key appr. 3sec.)

Display Parameter „Process“	Adjustment range Display „Set“
Cont	Controller on/off
	OFF Control action off (stand-by operation) on Control action on (ex works)
	Stand-by operation: All control outputs are switched „off“. The alarm-relays are not energized. All parameters can be preselected and preadjusted.
ConF	Controller configuration
	2P h 2-point-controller „heating“ (ex works) 2P c 2-point-controller „cooling“ 2Pnc 2-point-controller, non-linear-cooling*) 3P 3-point controller: "heating - off - cooling" 3Pnc 3-point controller: "heating - off - cooling", non-linear cooling*) *) Cooling action can be pre-selected with either linear or non-linear-cooling response curve (e.g. for vapour cooling).
SEn	Sensor selection
	P1 °C Pt 100, -50,0...100,0 °C P1 °F Pt 100, -58,0...212,0 °F P2 °C Pt 100, -100...200 °C P2 °F Pt 100, -148...392 °F P4 °C Pt 100, 0...400 °C (ex works) P4 °F Pt 100, 32...752 °F P8 °C Pt 100, 0...800 °C P8 °F Pt 100, 32...1472 °F L4 °C T/C Fe-CuNi (L), 0...400 °C L4 °F T/C Fe-CuNi (L), 32...752 °F L8 °C T/C Fe-CuNi (L), 0...800 °C L8 °F T/C Fe-CuNi (L), 32...1472 °F J8 °C T/C Fe-CuNi (J), 0...800 °C J8 °F T/C Fe-CuNi (J), 32...1472 °F n1 °C T/C NiCr-Ni (K), 0...1200 °C n1 °F T/C NiCr-Ni (K), 32...2192 °F S1 °C T/C Pt10Rh-Pt (S), 0...1600 °C S1 °F T/C Pt10Rh-Pt (S), 32...2912 °F 0-20 Current-Input 0-20mA 4-20 Current-Input 4-20mA

If the Sensor selection is changed, the following parameters will be reset and need to be re-adjusted:

Parameter „Cont“:	OFF	Setpoint:	Measuring range buttom end
Alarm values:	OFF	Switch-point difference:	0
Process value offset:	OFF		
Lower setpoint limitation:	Measuring range buttom end		
Higher setpoint limitation:	Measuring range top end		
Softstart:	OFF	Softstart setpoint:	OFF
Setpoint 2:	OFF	Setpoint ramp values:	OFF

Display Parameter
„Process“

Adjustment range
Display „Set“

The following parameters are only shown and only valid for standard signal inputs (0...20mA, 4...20mA). The difference between the bottom end of the display range and the top end must amount to a minimum of 100 units and a maximum of 2000 units.

rA.SP	decimal points	0; 1; 2	(ex works: 1)
rA.Hi	display range top end	rA.Lo+100digit ... 9999	(ex works: 100,0)
rA.Lo	display range bottom end	-1999 ... rA.Hi-100digit	(ex works: 0,0)

SP.Hi **higher setpoint limitation** SP.Lo ... top range (ex works: 400)

SP.Lo **lower setpoint limitation** bottom range ... SP.Hi (ex works: 0)

Co.A3	Alarm 3-Configuration OFF	alarm OFF, no alarm signalisation	(ex works)
	(switches relay OUT 3)		
	1	signal contact:	off-on
	2	limit contact:	off-on
	3	limit comparator:	off-on-off
	4	signal contact:	on-off
	5	limit contact:	on-off
	6	limit comparator:	on-off-on
	7	limit comp. with start-up suppression:	off-on-off

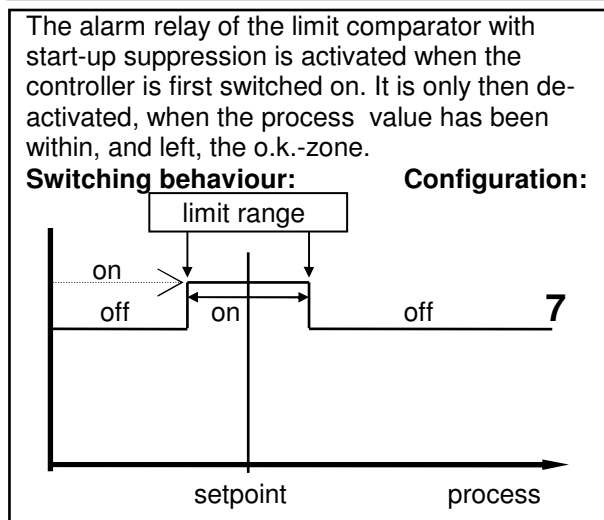
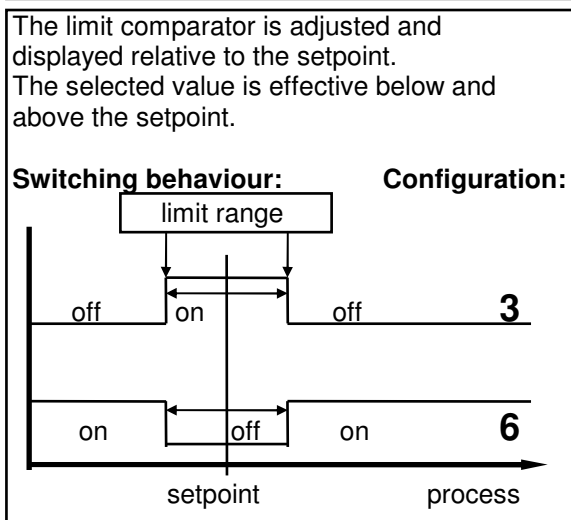
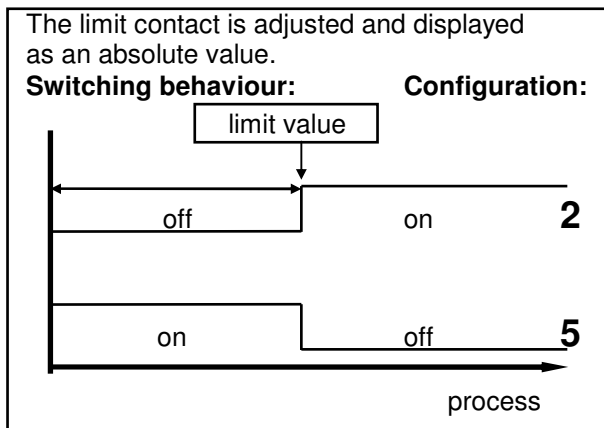
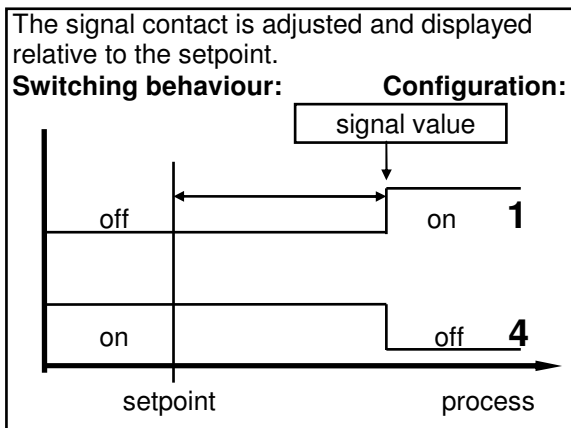

on: Relay "activated" or bistable voltage output "high".
off: Relay "not active" or bistable voltage output "low".

Display Parameter „Process“	Adjustment range Display „Set“				
rE.A3	Relay A3 switching behaviour	dir	on:	LED 3 „on“.	Relay A3 "activated"
			off:	LED 3 „off“.	Relay A3 "not active"
		inv	on:	LED 3 „on“.	Relay A3 "not active"
			off:	LED 3 „off“.	Relay A3 "activated"
Co.A2 Alarm 2-Configuration (switches relay OUT 2)	OFF		alarm OFF, no alarm signalisation	(ex works)	
		1	signal contact:	off-on	
		2	limit contact:	off-on	
		3	limit comparator:	off-on-off	
		4	signal contact:	on-off	
		5	limit contact:	on-off	
		6	limit comparator:	on-off-on	
7	limit comp. with start-up suppression:	off-on-off			
rE.A2	Relay A2 switching behaviour	dir	on:	LED 2 „on“.	Relay A2 "activated"
			off:	LED 2 „off“.	Relay A2 "not active"
		inv	on:	LED 2 „on“.	Relay A2 "not active"
			off:	LED 2 „off“.	Relay A2 "activated"

Please note:

In case of sensor error the alarms will react in the same way as range override.
The alarm contacts therefore do not offer protection against all types of plant breakdown.
With this in mind, we recommend the use of a second, independent monitor unit.

If a setpoint ramp has been programmed, the alarms that are relative to the setpoint (signal contact, limit comparator) follow the setpoint up the ramp.

Softstart (general function):

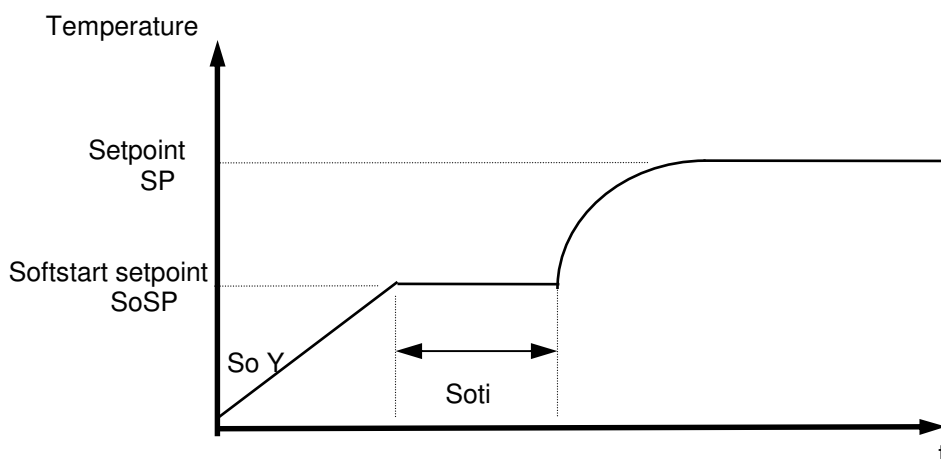

During the softstart the controllers' output response is limited to a pre-selected ratio, in order to achieve a slow baking out of high performance heat cartridges. Simultaneously the output clock frequency is quadrupled. Once the process value reaches the softstart setpoint, it remains stable at this value for a pre-selected hold-duration time. At the end of this period the process value rises to the valid setpoint. This results in a slower, more regular heating period.

For this purpose the bistable voltage output must be chosen, that actuates SSR relays.

If the softstart is active, the controllers' autotune function can't operated (Er.OP).
If a setpoint-ramp has been programmed, the softstart has priority, and the ramp will only become active after the softstart has been completed.

The softstart only works, if the parameter „1 P“ (prop. band) is programmed > 0,1%.
During the softstart-phase it is not possible to change the setpoint values.
For this, the softstart-phase has to be stopped: Set parameter „So.St“ to „OFF“

So.St Softstart	OFF: Softstart not active (ex works) So.Y, So.SP and So.ti are not shown.	
	On: Softstart active Adjust the following parameters.	
So. Y Softstart output ratio	10 ... 100%	(ex works: 30%)
So.SP Softstart setpoint	SP.Lo SP.Hi	(ex works: 0)
So.ti Softstart duration time	OFF; 0,1 ... 9,9 min.	(ex works: OFF)

Display Parameter „Process“	Adjustment range Display „Set“		
Hand	manual output ratio	OFF Auto Man	(ex works)
		Setting: OFF Controller action, no manual output ratio	
		Setting: Auto In event of sensor break the controller automatically maintains the last valid output ratio as the actuating signal. An „H“ is then displayed as the first digit in the setpoint display, followed by the valid output ratio. This ratio can be manually altered in steps of 1% (up/down-keys; enter). Under the following circumstances, the output ratio will be 0%: - if the output ratio at time of the sensor break was 100%. - if the control deviation was more than 0,25% of the total range at the time of sensor break. - if the prop. band (P; xp) = 0. - if the softstart function was active at the time of the sensor break. A few seconds after the sensor break has been rectified, the controller returns to automatic operation and calculates the required output ratio. An additional signal can be issued in the event of sensor break, if the alarm contacts are programmed accordingly.	
		Setting: MAn The controller now operates only as an actuator. Within the operation level, an output ratio can be entered instead of the setpoint. Setpoint display: An „H“ is then displayed as the first digit in the setpoint display, followed by the output ratio. H - xx: cooling output ratio. Process display: Displays the actual process value. There is no controlling action.	
LOC	Adjustment lock	OFF P C n.SP1 ALL	no adjustment lock (ex works) parameter and configuration levels locked all parameters apart from SP1 locked (not SP1) all parameters locked
		All parameters that have been locked with „LOC“ can be selected and read, but not altered. This adjustment cannot be changed if the external contact K2 is closed.	

The following parameters are only valid, if the unit is equipped with a **CAN interface**.

Adr	Unit address	1 127	(ex works: 1)
bAud	Baud rate	10k, 20k, 50k, 100k, 125k, 250k, 500k, 1MBaud	(ex works: 20)
	CANopen-specification:	CANopen Master: no CANopen Slave: yes Extended Boot-up: no Minimum Boot-up: yes COB ID Distribution: yes; default via SDO Node ID Distribution: no; via device keyboard No. of POD's: 0RX, 1TX PDO Modes: async. Variable PDO mapping: no Emergency message: yes Life guarding: yes No. of SDO's: 1RX, 1TX Device Profile: CiA DS-404	
	Details:	- Object Dictionary ELOTECH - Shortform Object Dictionary ELOTECH R1140 - CANopen Device Profile CiA DS-404	

The following parameters are only valid, if the unit is equipped with a **PROFIBUS DP – interface**.

rEMO	Remote operation	OFF on	Controller operation via the keyboard. It is only possible to programm and operate the controller via the Profibus – interface.
Adr	Device address	1 125	
bAud	Baud rate	The baud rate will be detected and displayed automatically. It is not adjustable.	
		ndEt	no baud rate detected.
		12 n	12 MBaud
		6 n	6 MBaud
		3 n	3 MBaud
		1,5 n	1,5 MBaud
		500	500 kBaud
		187,5	187,5 kBaud
		93,75	93,75 kBaud
		45,45	45,45 kBaud
		19,2	19,2 kBaud (will not be supported)
		9,6	9,6 kBaud (will not be supported)
	Details:	ELOTECH - Profibus DP description	

Display Parameter
„Process“

Adjustment range
Display „Set“

The following parameters are only valid, if the unit is equipped with a **serial interface: RS232, RS485, 0/20mA**.

Prot	Protocol preselection	ELO 53	ELOTECH- standard protocol Protokoll 53 (type 5310)
Adr	Unit adress	1 ... 255	(ex works: 1) The computer addresses the unit/controller at this adress. Each unit has ist own adress. With RS-485 it is possible to adress 32 units.
For	Data format	7E1 7o1 7E2 7o2 7n2 8E1 8o1 8n1 8n2	7 data, even, 1 stopbit 7 data, odd, 1 stopbit 7 data, even, 2 stopbit 7 data, odd, 2 stopbit 7 data, none, 2 stopbit 8 data, even, 1 stopbit 8 data, odd, 1 stopbit 8 data, none, 1 stopbit 8 data, none, 2 stopbit
bAud	Baud rate	OFF; 0,3 ... 9,6 kBaud	(ex works: 9,6) The baud rate denotes the transmission rate at which one bit is transmitted.
	Details:	Sep. interface description: - ELOTECH – standard-protocol: SST1300-E - Protokoll 53: SST1140-53-E.DOC	

1140

EL.xx Control number

No function. End of configuration level

6.2 Parameter Level

(Press „P“ and „E“-key appr. 1sec.)

Display Parameter „Process“	Adjustment range Display „Set“
Y	valid output ratio -100...100 % The output ratio shows the momentary calculated ratio. It cannot be altered. The display is in percent of the installed performance capability for heating or cooling. Output ratio for cooling is shown as a negative value.
1 LY	OUT1- or OUT4 output ratio limit 0...100 % (ex works: 100)
2 LY	OUT2- or OUT4 output ratio limit 0...100 % (ex works: 100) Only: heating-off-cooling configuration. A limitation of the output ratio is only necessary when: - the heating or cooling energy supply is grossly overdimensioned compared to the power required, or - to turn off a control output (setting = 0%). Under normal circumstances no limitation is needed (setting = 0%). The limitation becomes effective, when the controllers' calculated output ratio is greater than the maximum permissible (limited) ratio. Warning! The output ratio limitation does not work during autotune.
1 P	OUT1 - prop.band (P) or OUT4 OFF; 0,1...100,0 % (ex works: 3,0) if Xp = OFF, the next parameter to follow is „1 Sd“ = control sensivity OUT1
1 d	OUT1 - rate (D) or OUT4 OFF; 1...200 secs (ex works: 30)
1 J	OUT1 - reset (I) or OUT4 OFF; 1...1000 secs (ex works: 150) Normally the controller works using PD/I control action. This means, controlling without deviation and with practically no overshoot during start-up. The control action can be altered in its structure by making the following adjustments to the parameters: a. no control action, on-off (setting P = OFF) b. P-action (setting D and I = 0) c. PD-action (setting I = 0) d. PI-action (setting D = 0) e. PD/I modified PID-action
1 CY	OUT 1 - cycle time heating or OUT4 0,5...240,0 secs (ex works: 10,0) The switching frequency of the actuator can be determined by adjusting the cycle time. This is the total time needed for the controller to switch on and off once. OUT 1: Relay outputs: cycle time > 10 secs OUT 4: Bistable voltage outputs: cycle time 0,5...10 secs

Display Parameter
„Process“

Adjustment range
Display „Set“

1 Sd	control sensitivity heating OUT1 or OUT4	Only if 1 P = OFF : OFF; 0,1... 80,0 °K OFF; 0,01... 8,00 °K	(ex works: 0,1)
-------------	--	--	-----------------

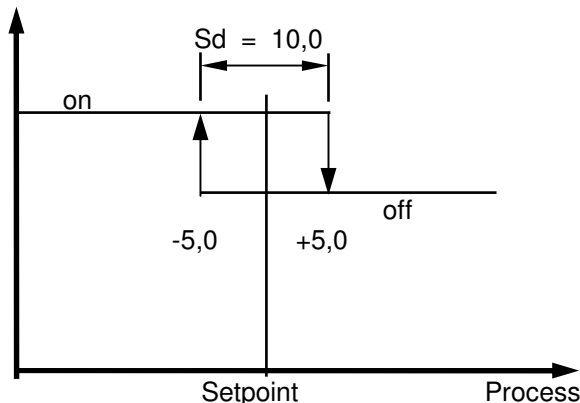

The following parameters apply **only to the configuration of heating-off-cooling** controllers and are valid for cooling control action:

Sh	switch-point difference	OFF; 0,1...80,0 °K OFF; 0,01...8,00 °K This parameter raises the setpoint (switch-point) for cooling output by the displayed value. It can be help to reduce the switching frequency between the heating and cooling outputs, if this is to high. Simultaneously activation of heat and cool outputs is not possible.	(ex works: OFF)
2 P	OUT2- prop.band (P) or OUT4	OFF; 0,1...100,0 % if Xp = OFF, the next parameter to follow is „2 Sd“ = control sensivity OUT2	(ex works: 3,0)
2 d	OUT2- rate (D) or OUT4	OFF; 1...200 secs	(ex works: 30)
2 J	OUT2- reset (I) or OUT4	OFF; 1...1000 secs Control action: see description OUT1 (heating)	(ex works: 150)
2 CY	OUT 2- cycle time cooling or OUT4	0,5...240,0 secs	(ex works: 10,0)
2 Sd	control sensitivity cooling OUT2 or OUT4	Only if 2 P = OFF : OFF; 0,1... 80,0 °K OFF; 0,01... 8,00 °K	(ex works: 0,1)

Display Parameter „Process“	Adjustment range Display „Set“
OPt selftuning (autotune)	OFF self tuning out of action on self tuning on request (one time) Auto self tuning automatically if the controller is switched on and if the difference between process value and setpoint is > 7 % of the range.

The tuning algorithm determines the characteristic values within the controlled process, and calculates the valid feedback parameters (P,D,I) and the cycle time ($C = 0.3 \times D$) of a PD/I-controller for a wide section of the range.

The determined parameters for heating are also adopted for cooling.

The selftuning activates during start-up shortly before the setpoint is reached. The setpoint must amount to the least 5% of the total range.

If activated after the setpoint has already been reached, the temperature will first drop by approx. 5% of the total range, in order to detect the exact amplification of the process.

The tuning algorithm can be activated at any time by selecting the OPT=on and pressing the „E“-key.

During self tuning „OPT“ is shown in the display, alternating with the setpoint value.

Using the heat-cool controller, the temperature drop will be accelerated by switching on the cooling for a short duration.

It is not possible to start the selftuning mode, if the softstart function or the manual mode is activated.

Display: error warning „Er.OP“. Press Key „E“ to quit the error warning.

After having calculated the correct feedback parameters, the controller will lead the process value to the setpoint.

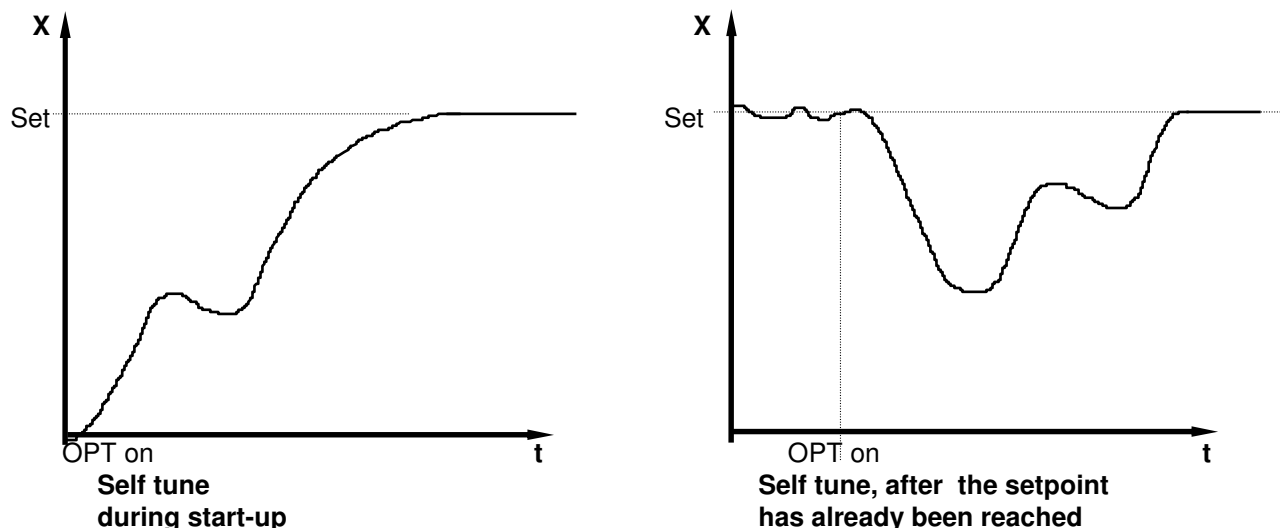

Self-tuning can be stopped by selecting the option OPT = OFF and pressing the „E“ - key.

OFSt process value offset -999 ... OFF ... 1000 °K (ex works: OFF)
 -99,9 ... OFF ... 100,0 °K

This parameter serves to correct the input signal, e.g. for:

- the correction of a gradient between the measuring point and the sensor tip,
- the line resistance balancing of 2-line RTD (Pt100) sensors and
- correction of the control deviation when using P- or PD-action.

If for example the offset value is set to +5°C, then the real temperature measured by the sensor (when process is balanced) is 5°C less than the setpoint and the displayed process value.

6.3 Operating Level

Display Parameter „Process“	Adjustment range Display „Set“
--------------------------------	-----------------------------------

Process

and

Setpoint 1 OFF, SP.Lo...SP.Hi (ex works: 0)

are displayed simultaneously.

This is the basic display.

SP1 Setpoint 1 SP.Lo ... SP.Hi (ex works: OFF)
 If parameter „Cont“ is programmed „on“, the setpoint can be adjusted directly in the operating level and is active, if the external contact K1 is opened.
 If parameter „Cont“ is programmed „OFF“, the parameter SP1 has to be selected (press key „P“). Then the setpoint can be preadjusted.

SP2 Setpoint 2 OFF; SP.Lo ... SP.Hi (ex works: OFF)
 The 2. setpoint is active, when the external contact K1 is closed.
 The corresponding LED „SP2“ lights up on the faceplate, and the second set-point is shown in the display.
 Please note, that the value of the second setpoint cannot be changed in the operating level.
 In order to change the value the parameter SP2 has to be selected.

SP \uparrow rising ramp OFF; 0,1...100,0 °C/min. or °F/min. (ex works: OFF)

SP \downarrow falling ramp OFF; 0,1...100,0 °C/min. or °F/min. (ex works: OFF)

A programmed ramp is always activated when the setpoint is altered or when the mains supply is switched on. The ramp constructs itself out of the momentary process value and the pre-selected setpoint. If the ramp is active, the corresponding LED lights up on the faceplate. The ramp can be activated for both setpoint1 and setpoint2. By programming the second setpoint accordingly a setpoint profile can be obtained (please see example below).

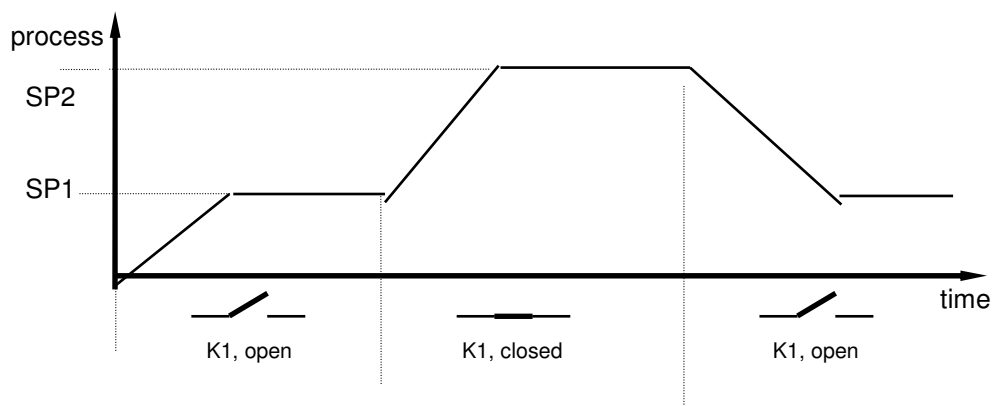

Display Parameter „Process“	Adjustment range Display „Set“	
AL 3 Alarm 3, Out3	signal contact, setpoint dependent	
	OFF; -999...1000 °K	(ex works: OFF)
	OFF; -99,9...100,0 °K	
	limit comparator, setpoint dependent	
	OFF; 1...1000 °K	
	OFF; 0,1...100,0 °K	
	limit contact, process value dependent	
	OFF; range bottom ... range top	
AL 2 Alarm 2, Out2	Alarm 2 is only available, if the controller is programmed as a 2-point-controller in the configuration-level.	
	signal contact, setpoint dependent	
	OFF; -999...1000 °K	(ex works: OFF)
	OFF; -99,9...100,0 °K	
	limit comparator, setpoint dependent	
	OFF; 1...1000 °K	
	OFF; 0,1...100,0 °K	
	limit contact, process value dependent	
	OFF; range bottom ... range top	

The range of adjustment is dependant on the sensor and the alarm configuration. Both have to be set in the configuration level.

7. CANopen, general

Please note: A CAN-interface has to be connected on it's both ends with terminating resistors.

See:

- Object Dictionary ELOTECH
- Shortform Object Dictionary ELOTECH R1140
- CANopen Device Profile CiA DS-404 -

Download: www.elotech.de → Technical Data → CANopen - Description

8. Profibus DP, general

The controller series R1140 can be equipped with a Profibus-DP-inteface acc. EN 50170.
It is essential, that one has well experience in installing a Profibus-device.

The communication is always controlled by the Profibus-master. The control device is always the „slave“.
All process-, parameter- and configuration datas can be transferred.

Interface: RS485
Twisted pair 2-wire connection. See EN 50170, Chapt. 2

Network-Topology: Linear bussystem with activ bus termination on both ends.
Spot lines are possible (depending of the used cable type):
3-12Mbit/sec. = max. lenght: 1,5m
1,5Mbit/sec. = max. lenght: 6,5m

Baud rate and wiring lenght (without repeater):
The baud rate will be detected by the Profibus-master automatically.
The maximal wiring lenght depends of the used baud rate.

Baud rate	Max. wiring lenght
93,745 kbit/sec.	1200m
187,5 kbit/sec.	1000m
500 kbit/sec.	400m
1,5 Mbit/sec.	200m
3 – 12 Mbit/sec.	100m

Connections: The terminals (signals) VP and GND only are to be used to connect the external terminating resistors.
There are no further connections allowed.

Device Adress: Each device has it's own adress (1...125), wich will be programmed via parameter „Adr“.
If a new adress number has been programmed, please switch the device off and on again,
to overtake the new adress.
There are up to 32 device addresses in one segment programable.
With the help of a repeater up to 127 devices can be connected.

Special:

- Configuration channel für reading and writing of all available parameters.
- Configurable process data moduls.
- Diagnostic warnings, to detect sensor- and/or system errors.
- Easy connection to IPC`s or PLC`s.

Information about the Profibus-communication: see parameter „Adr“.

Dec.-point off: Profibus not connected or master not activ.
Dec.-point flashes: Master detected – Device expects parameter
Dec.-point on: Data Exchange Modus

See: **Elotech-Discription and Data transfer Profibus-DP**

9. Error Displays

Display	Cause	Possible remedy
SP.Lo	Lower setpoint limit has been reached	Reduce limit, if need be
SP.Hi	Upper setpoint limit has been reached	Increase limit, if need be
LOC	Parameter has been locked	Unlock, if need be
Hand	Instrument operates in manual mode Automatically switch over because of a sensor error (if this is programmed).	Check sensor and cable
Er.Hi	Top range end has been exceeded, sensor defect	Check sensor and cable
Er.Lo	Bottom range end has been exceeded, sensor defect	Check sensor and cable
Er.OP	Selftuning error	Extinguish error signal by pressing the „E“-key. Check the self tuning conditions and restart.
Co.A3	Alarm configuration alarm A3 = OFF	No alarm monitoring possible
Co.A2	Alarm configuration alarm A2 = OFF	No alarm monitoring possible
Er.SY	System error	Extinguish error signal by pressing the „E“-key. Check all parameters. If the error signal continues please send the controller back for examination.

10. Installation Instructions

Make certain that the devices described here are used only for the intended purpose.

They are intended for installation in control panels.

The controller must be installed so that it is protected against impermissible humidity and severe contamination. In addition, make sure that the permitted ambient temperature is not exceeded.

The electrical connections have to be made by well trained personnel according to the relevant locally applicable regulations only.

If using a thermocouple sensor, the compensation cables must be laid directly to the controller terminals.

Transducers must be connected only in compliance with the programmed range.

Transducer cables and signal lines (e.g. logic or linear voltage outputs) must be laid physically separated from control lines and mains voltage supply cables (power cables).

To keep the CE-conformity it is necessary, to use for sensor- and low voltage signal lines shielded cables. Spatial separation between controller and inductive loads is recommended.

Interference from contactor coils must be suppressed by connecting adapted RC-combinations parallel to the coils.

Control circuits (e.g. for contactors) should not be connected to the mains power supply terminals of the controller.

IMPORTANT:

Before operation, the unit must be configured for its intended purpose (e.g. controller type, sensor type and range, alarm adjustment etc.).

Please see „Configuration Level“.

11. Parameter Adjustments

1. Configuration level:

Ex works:

Customers adjustments:

Cont	Controller function	on	
ConF	Controller Configuration	2P h	(heat-only)
Out4	Configuration Output OUT4	OFF	
SEn	Sensor Configuration	P4 °C	(0.400 °C, RTD)
rA.SP	decimal points	not displayed	
rA.Hi	display range top end	not displayed	
rA.Lo	display range bottom end	not displayed	
SP.Hi	Upper Setpoint Limitation	400	
SP.Lo	Lower Setpoint Limitation	0	
Co.A3	Alarm 3-Configuration	OFF	
rE.A3	Switching behaviour relay A3	dir	
Co.A2	Alarm 2-Configuration	OFF	
rE.A2	Switching behaviour relay A2	dir	
So.St	Softstart function	OFF	
So.Y	Softstart output ratio	not displayed	
So.SP	Softstart setpoint	not displayed	
So.ti	Softstart duration ime	not displayed	
HAnd	Auto-/Manual operation	OFF	
LOC	Adjustment lock	OFF	
CAN:			
Adr	Device adress	1	
bAud	Baud rate	20	
Profibus-DP:			
rEMo	remote operation	on	
Adr	Device address	1	
bAud	Baude rate	ndEt	(automatic installation)
RS232, RS485, 0/20mA:			
Prot	Protocoll preselection	ELO	
Adr	Device adress	1	
For	Data format	7E1	
bAud	Baud rate	9,6	
1140	Control number: EL.xx	read only	

2. Parameter level:**Ex works:****Customers adjustments:**

Y	Actual output ratio	read only	
1 LY	OUT 1/4- Output ratio limitation	100	
2 LY	OUT 2- Output ratio limitation	not displayed	
1 P	OUT 1/4- Proportional band (P)	3,0	
1 d	OUT 1/4- Rate (D)	30	
1 J	OUT 1/4- Reset time (I)	150	
1 CY	OUT 1/4- Output cycle time	15,0	
1 Sd	OUT 1/4- Control sensitivity	not displayed	
Sh	Switch-point difference	not displayed	
2 P	OUT 2- Proportional band (P) „cooling“	not displayed	
2 d	OUT 2- Rate (D) „cooling“	not displayed	
2 J	OUT 2- Reset time (I) „cooling“	not displayed	
2 CY	OUT 2- Output cycle time „cooling“	not displayed	
2 Sd	OUT 2- Control sensitivity „cooling“	not displayed	
OPt	Self tuning	OFF	
OFSt	Process value offset	OFF	

3. Operating level:**Ex works:****Customers adjustments:**

	Actual process value (process)	read only	
	Setpoint (set)	OFF	
SP2	Setpoint 2	OFF	
SP ↑	Setpoint ramp, rising	OFF	
SP ↓	Setpoint ramp, falling	OFF	
AL3	Alarm point 3	OFF	
AL2	Alarm point 2	OFF	



ELOTECH
INDUSTRIELELEKTRONIK GMBH

ELOTECH Industrieelektronik GmbH

Verbindungsstr. 27

D – 40723 Hilden

Tel. 0049 2103 / 23055 Fax. 0049 2103 / 23057

www.elotech.de

email:elotech@t-online.de