

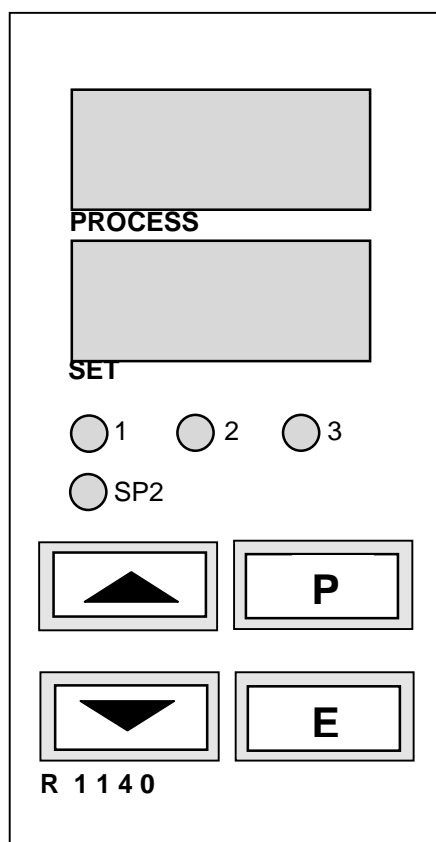

**ELOTECH**  
INDUSTRIELELEKTRONIK GMBH

## R 1140 : The Temperature Controller



Format: 48x96 mm (1/8-DIN)  
Installation depth: 122 mm

### Description and Operation Manual

## Contents

Type code	Page	2
Connection diagram		3
Technical data		4
Display and keyboard		5
Operating levels, general		6
Configuration level		7
Parameter level		13
<b>Operating level</b>		<b>16</b>
Error displays		17
Installation instructions		17
Parameterlist		18

**Please read this operating manual carefully before starting up.  
Observe the installation and connecting instructions.**

## Type Code

R 1140 - x - 00 - z

- ↓
- 1: Power supply: 230 VAC  
2: Power supply: 115 VAC  
3: Power supply: 24 VAC  
5: Power supply: 24 VDC, +/-25%
- ↓
- 00:** Sensor input (standard):  
Pt100 (RTD); Fe-CuNi (Type L), Type J, Type K, Type S; 0-20mA, 4-20mA
- 01:** Sensor input (option):  
Pt100 (RTD); Fe-CuNi (Type L), Type J, Type K, Type S; 0-10VDC
- ↓
- 10:** **2-Point- (heat-only or cool-only) / 3-Point- (heating-off-cooling) controller**  
OUT1: Relay and OUT4: bist. voltage 0/18VDC-signal  
OUT2: Relay  
OUT3: Relay
- 14:** **3-Point-step-controller**, see separate description (e.g. for motor valves)  
OUT1: Relay and OUT4: bist. voltage 0/18VDC-signal  
OUT2: Relay  
OUT3: Relay
- 60:** **Continous controller**  
OUT4: continous output signal 0/4...20mA  
OUT2: Relay, alarm 2  
OUT3: Relay, alarm 3  
**or**  
**2-Point- (heat-only or cool-only) / 3-Point- (heating-off-cooling) controller with analogue process output signal**  
OUT1: Relay  
OUT2: Relay  
OUT3: Relay  
OUT4: Process value output signal 0/4...20mA



## Technical Data

<b>Input Thermocouple:</b>	Built-in internal compensation point and protection against sensor breakage and incorrect polarity. Re-calibration not required for a line resistance of up to 50 Ohms. Calibration accuracy: $\leq 0,25\%$
<b>Input RTD:</b>	Built-in protection against sensor breakage and short circuit. Max. permissible line resistance by 3-wire connection: 80 Ohms Sensor current: $\leq 0,5$ mA Calibration accuracy: $\leq 0,2\%$
<b>Input 0/4-20mA:</b>	Load max. 10 Ohm
<b>Input 0-10VDC:</b>	Load $>10\text{KOhm/V}$
Linear error:	$\leq 0,2\%$
Influence of the ambient temperature:	$\leq 0,01\% / \text{K}$
<b>Setpoint selection (k1):</b>	Ext. potential-free contact, switching voltage appr. 24 V dc, max. 1 mA. Selection between SP1 (main setpoint) and SP2.
<b>Control outputs:</b>	- Relay (UR appr.), max. 250 Vac, max. 3 A (cos-phi = 1)  - Logic / bist. voltage signal, 0/18 V dc, max. 10 mA, short-circuit proof  - Continuous ( version R1140-60): 0/4...20 mA, Load max. 500 Ohm Linearity: $\leq 1,5\%$ Delay time: app. 2 secs.
<b>Alarm output:</b> -OUT 2:	- Relay (UR appr.), max. 250 Vac, max. 3 A (cos-phi = 1). Only for 2-point-controller and continuous-controller configuration.
-OUT 3:	- Relay (UR appr.), max. 250 Vac, max. 3 A (cos-phi = 1).
<b>Process output:</b> -OUT 4:	Only version R1140-60. Equivalent to the choosen range. 0/4...20 mA Load max. 500 Ohms Linearity: $\leq 1,5\%$ Delay time: app. 2 secs.
<b>7-Segment-Display:</b>	Process: 10 mm red, Set: 10 mm red
<b>Data protection:</b>	EAROM
<b>CE-Mark</b>	Tested according to 89 / 336 / EEC. EN 50081-2, EN 50082-2 Electr. safety: EN 61010
<b>Power supply:</b>	Standard: 230 V AC. $\pm 10\%$ , 48...62 Hz. Others possible. See Type Code.
<b>Connections:</b>	Screw terminals (UR appr.). Protection mode IP 20 (DIN 40050), Insulation class C.
<b>Permissible operating conditions:</b>	Operating temperature: 0...50 °C / 32...122 °F Storage temperature: -30...70 °C / -22...158 °F Climate class: KWF DIN 40040; Equivalent to annual average max. 75 % rel. humidity. No condensation.
<b>Casing:</b>	Format: 48 x 96 mm (DIN 43700). Installation depth 122 mm Panel cutout: 45 +0,6 mm x 92 +0,8 mm Material: Noryl, self-extinguishing, non-drip, UL 94-V1 Protection mode: IP 20 (DIN 40050), IP 50 front side
<b>Weight:</b>	app. 380g

Subject to technical improvements!

## Display and Keyboard

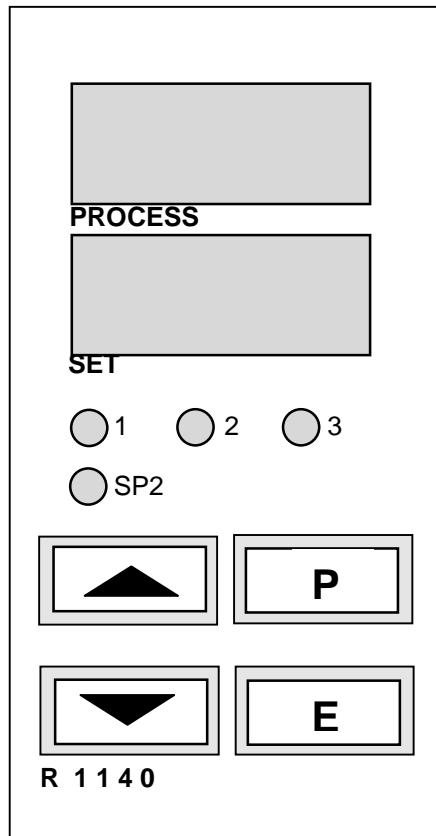

**Display PROCESS** : Process Value  
**Display SET** : Setpoint Value

**LED 1:** Output OUT1 active: Control Output

**LED 2:** Output OUT2 active: Control Output or Alarm Output A2

**LED 3:** Output OUT3 active: Alarm Output A3

**LED SP2:** Setpoint 2 active

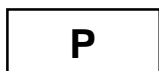

Parameter key



Adjustment of chosen parameter (e.g. setpoint) to higher or lower values.  
 E.g. setpoint adjustment.



Short operation: single-step adjustment

Longer operation: quick-scanning

When the parameter adjustments have been altered but not entered, the display will flash bright/dark.



Confirmation and storage of the pre-selected values

The display will shortly show a light chain as a control of this function.

To return to the process- and setpoint-display: press „E“ appr. 2 sec..

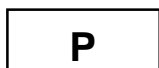

Sets the parameter back to the originally stored value.

Any alterations made to the parameters, that are not confirmed (E-key) within 30 seconds, will not be accepted and the parameter will return to its originally stored value.

## Operating Levels

The operation of the controller is divided into three levels.

Two seconds after switching on the unit, the controller will automatically be in the operating level.

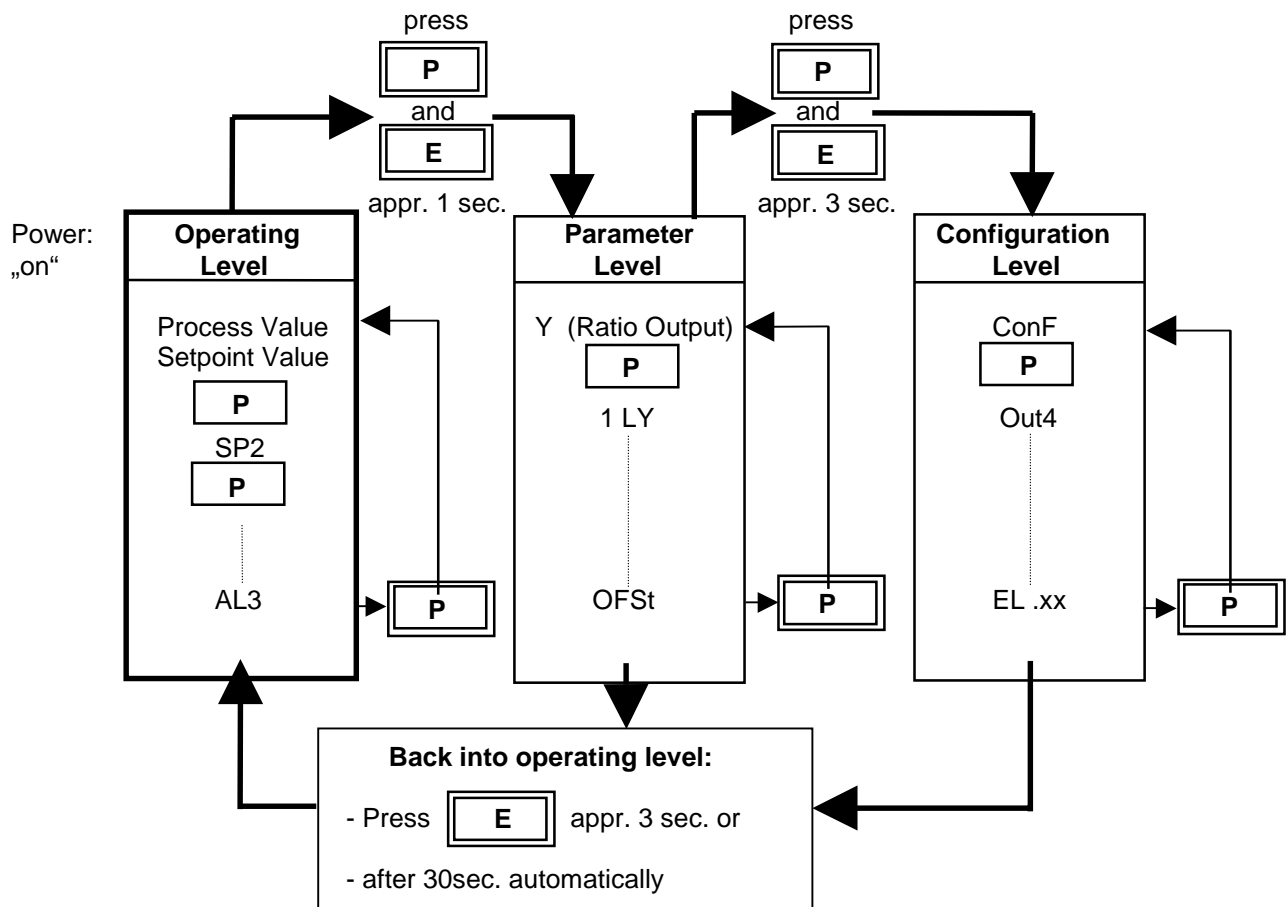

### Operating level

Process- and setpoint value will be displayed simultaneously.

Within the operating level the setpoints and the alarm value can be adjusted by pressing the "▲"/"▼" - keys.

Every adjustment has to be quit by pressing the „E“ - key.

All parameters within the operating level can, in succession, be displayed by pressing the „P“ - key and adjusted by pressing the "▲"/"▼" - keys.

### Parameter level

Enter this level by pressing the „P“ and „E“-key appr. 1 sec. simultaneously.

Within the parameter level the values are adjusted to suit the control behaviour to the individual process.

Leave this level by pressing key „E“ appr. 3 sec..

### Configuration level

Enter this level by pressing the „P“ and „E“-key appr. 3 sec. simultaneously.

In the configuration level the controller type, sensor type, the sensor range, the alarm behaviour and the output type can be pre-selected.

**This primary information has to be entered before taking the controller into operation.**

The display of each single parameter within the parameter and configuration levels, and their adjustment, are made in the same way as within the operating level.

After either pressing the „E“ - key for approx. 3 seconds, or waiting for a period of approx. 30 seconds, the unit will automatically return to the operating level (display of process value and setpoint).

Display "Process"	Parameter	Display „Set“	
<b>ConF</b>	<b>Controller configuration</b>	2P h	2-point- or continuous-(OUT4) controller „heating“ (ex works)
		2P c	2-point- or continuous-(OUT4) controller „cooling“
		2Pnc	2-point- or continuous-(OUT4)controller, non-linear-cooling*)
		3P	3-point controller:"heating - off - cooling"
		3Pnc	3-point controller:"heating - off - cooling", non-linear cooling*)
			*) Cooling action can be pre-selected with either linear or non-linear-cooling response curve(e.g. for vapour cooling).
<b>Out4</b>	<b>Configuration Output 4</b>	OFF	OUT4 not active
	<b>Only valid for type R1140-10:</b>		
	- Controller output, instead of OUT1:	bi 1	Logic output / bistable voltage signal 0/18VDC
	- 3-point-controller output „cooling“, instead of OUT2:	bi 2	Logic output / bistable voltage signal 0/18VDC
	<b>Only valid for type R1140-60:</b>		
	- Controller output, instead of OUT1:	C1. 0	0...20mA control output
		C1. 4	4...20mA control output
	- 3-point-controller output „cooling“, instead of OUT2:	C2. 0	0...20mA control output
		C2. 4	4...20mA control output
	- Process value output:	Pr. 0	0...20mA process value output
		Pr. 4	4...20mA process value output
<b>Sen</b>	<b>Sensor selection</b>	P1 °C	Pt 100, -50,0...100,0°C
		P1 °F	Pt 100, -58,0...212,0°F
		P2 °C	Pt 100, -100...200 °C
		P2 °F	Pt 100, -148...392 °F
		P4 °C	Pt 100, 0...400 °C (ex works)
		P4 °F	Pt 100, 32...752 °F
		P8 °C	Pt 100, 0...800 °C
		P8 °F	Pt 100, 32...1472 °F
		L4 °C	T/C Fe-CuNi (L), 0...400 °C
		L4 °F	T/C Fe-CuNi (L), 32...752 °F
		L8 °C	T/C Fe-CuNi (L), 0...800 °C
		L8 °F	T/C Fe-CuNi (L), 32...1472 °F
		J8 °C	T/C Fe-CuNi (J), 0...800 °C
		J8 °F	T/C Fe-CuNi (J), 32...1472 °F
		n1 °C	T/C NiCr-Ni (K), 0...1200 °C
		n1 °F	T/C NiCr-Ni (K), 32...2192 °F
		S1 °C	T/C Pt10Rh-Pt (S), 0...1600 °C
		S1 °F	T/C Pt10Rh-Pt (S), 32...2912 °F
		0-20	Current-Input 0-20mA <u>or</u>
			Voltage-Input 0-10VDC (Option: 01)
		4-20	Current-Input 4-20mA

If the Sensor selection is changed, the following parameters will be reset (setting in brackets) and need to be re-adjusted:

All Setpoints (set to OFF); ; alarm values (OFF); control sensivity ( 0); process offset(OFF); lower setpoint limitation (SP.Lo); higher setpoint limitation (SP.Hi).

Display "Process"	Parameter	Display „Set“
----------------------	-----------	------------------

---

The following parameters are only valid for standard signal inputs (0...20mA, 4...20mA). The difference between the bottom end of the display range and the top end must amount to a minimum of 100 units and a maximum of 2000 units. By adjustment of one of the above parameters, the other in this case will automatically follow.

<b>rA.SP</b>	<b>decimal points</b>	0; 1; 2	(ex works: 1)
<b>rA.Hi</b>	<b>display range top end</b>	rA.Lo ... 9999	(ex works: 100,0)
<b>rA.Lo</b>	<b>display range bottom end</b>	-1999 ... rA.Hi	(ex works: 0,0)

<b>SP.Hi</b>	<b>higher setpoint limitation</b>	SP.Lo ... top range	(ex works: 400)
--------------	-----------------------------------	---------------------	-----------------

<b>SP.Lo</b>	<b>lower setpoint limitation</b>	bottom range ... SP.Hi	(ex works: 0)
--------------	----------------------------------	------------------------	---------------

Display  
"Process"

Parameter

Display  
„Set“

**Co.A3 Alarm 3-Configuration**  
(OUT 3)

OFF  
1  
2  
3  
4  
5  
6  
7

alarm OFF, no alarm signalisation (ex works)  
signal contact: off-on  
limit contact: off-on  
limit comparator: off-on-off  
signal contact: on-off  
limit contact: on-off  
limit comparator: on-off-on  
limit comp. with start-up suppression: off-on-off

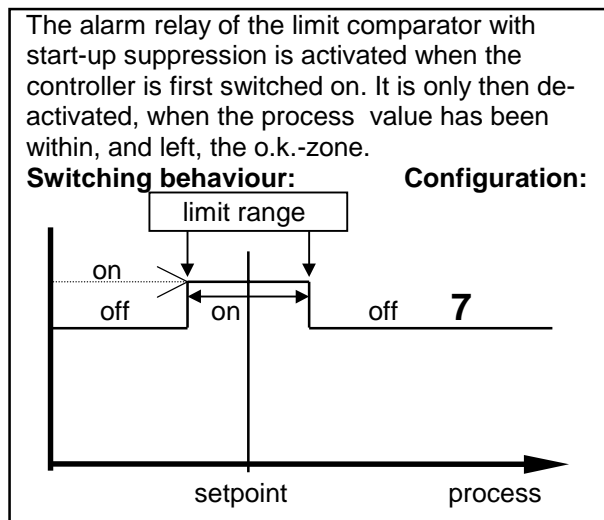
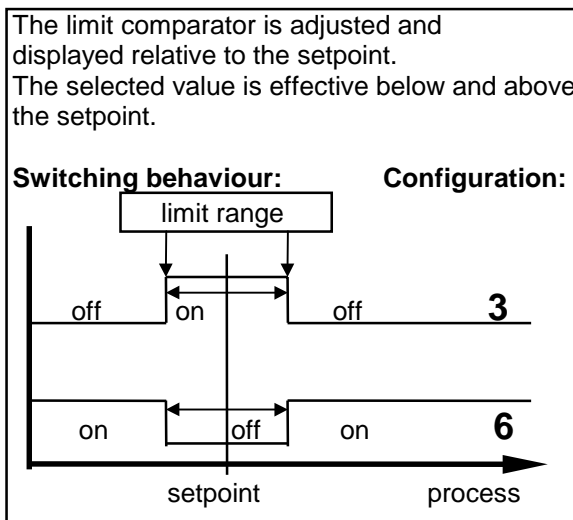
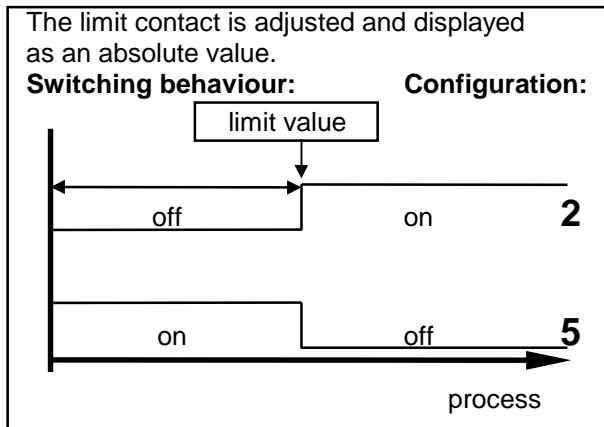
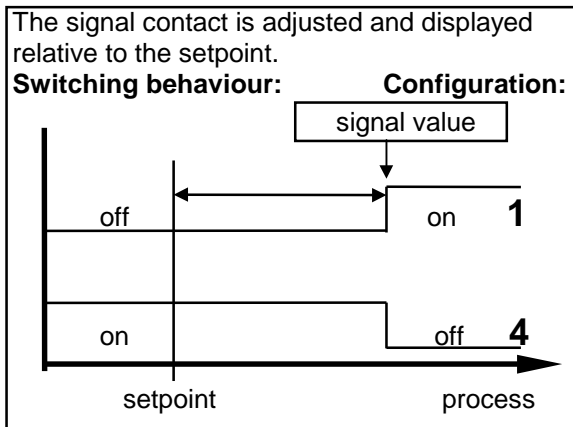

on: Relay "activated" or bistable voltage output "high".  
off: Relay "not active" or bistable voltage output "low".

If a setpoint ramp has been programmed, the alarms that are relative to the setpoint (signal contact, limit comparator) follow the setpoint up the ramp.

**Please note:**

In case of sensor error the alarms will react in the same way as range override. The alarm contacts therefore do not offer protection against all types of plant breakdown. With this in mind, we recommend the use of a second, independent monitor unit.

**Co.A2 Alarm 2-Configuration** see Co.A3 (alarm 3 - configuration)  
(switches OUT 2)

Only for 2-point- (heat-only) , 3-point-(heating mode) and continuous- (heating) controller configurations:

### Softstart (general function):

Temperature

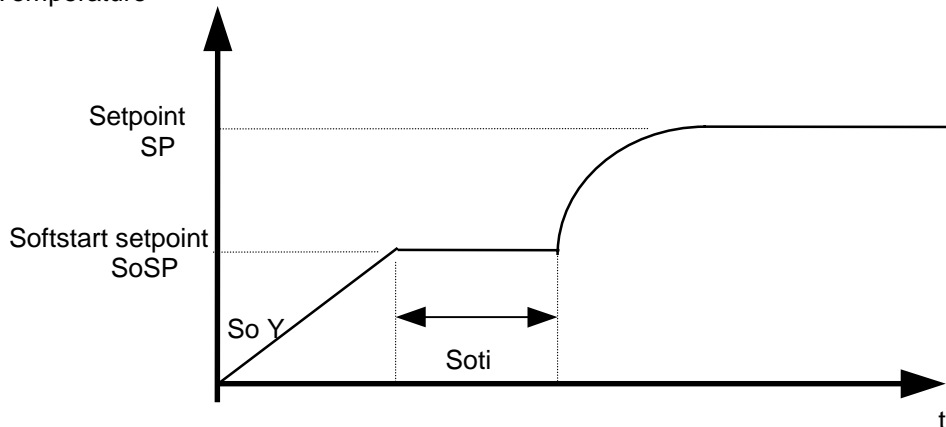

During the softstart the controllers' output response is limited to a pre-selected ratio, in order to achieve a slow baking out of high performance heat cartridges.

Simultaneously the output clock frequency is quadrupled. Once the process value reaches the softstart setpoint, it remains stable at this value for a pre-selected hold-duration time.

At the end of this period the process value rises to the valid setpoint.

This results in a slower, more regular heating period.

For this purpose the bistable voltage output must be chosen, that actuates SSR relays.

If the softstart is active, the controllers' autotune function can't operated (Er.OP).

If a setpoint-ramp has been programmed, the softstart has priority, and the ramp will only become active after the softstart has been completed.

The softstart only works, if the parameter „1 P“ (prop. band) is programmed  $> 0,1\%$ .

During the softstart-phase it is not possible to change the setpoint values.

For this, the softstart-phase has to be stopped.

<b>So. Y</b>	<b>Softstart output ratio</b>	OFF: Softstart not active 10 ... 100%	(ex works)
<b>So.SP</b>	<b>Softstart setpoint</b>	range: SP.Lo .... SP.Hi	(ex works: 0)
<b>So.ti</b>	<b>Softstart duration time</b>	OFF; 0,1 ... 9,9 min.	(ex works: OFF)

Display "Process"	Parameter	Display „Set“
<b>Hand</b>	<b>manual output ratio</b>	OFF (ex works) Auto Man  <u>Setting: OFF</u> not active  <u>Setting: Auto</u> In event of sensor break the controller automatically maintains the last valid output ratio as the actuating signal. An „H“ is then displayed as the first digit in the setpoint display, followed by the valid output ratio. This ratio can be manually altered in steps of 1% (up/down-keys; enter). Under the following circumstances, the output ratio will be 0%: - if the output ratio at time of the sensor break was 100%. - if the control deviation was more than 0,25% of the total range at the time of sensor break. - if the prop. band (P; xp) = 0. - if the soft start was active at the time of the sensor break. A few seconds after the sensor break has been rectified, the controller returns to automatic operation and calculates the required output ratio. An additional signal can be issued in the event of sensor break, if the alarm contacts are programmed accordingly.  <u>Setting: MAn</u> The controller now operates only as an actuator. Within the operation level, an output ratio can be entered instead of the setpoint. An „H“ is then displayed as the first digit in the setpoint display, followed by the output ratio. - : cooling output ratio. There is no controlling action.

Display "Process"	Parameter	Display „Set“
<b>Co.c1</b>	<b>Function of external contact k1</b>	<p>Loc    k1: open        = Adjustment lock only via "Software Code"              k1: closed      = Adjustment locked                                  (according to the chosen software code)</p> <p>SP2    k1: open        = Setpoint 1 (SP1) valid              k1: closed      = Setpoint 2 (SP2) valid</p>
<b>LOC</b>	<b>Adjustment lock</b>	<p>OFF        no adjustment lock (ex works)  P C        parameter and configuration levels locked  n.SP1      all parameters apart from SP1 locked (not SP1)  ALL        all parameters locked  All parameters that have been locked with „LOC“ can be selected and read, but not altered.  This adjustment cannot be changed if the external contact k1 is closed and if parameter „Co.c1“ = Loc:</p>
<b>1140</b>	<b>EL.xx</b>	<b>Control number</b>
		end of configuration level

## Parameter Level

Display "Process"	Parameter	Display „Set“
Y	<b>valid output ratio</b>	-100...100 % The output ratio shows the momentary calculated ratio. It cannot be altered. The display is in percent of the installed performance capability for heating or cooling. Output ratio for cooling is shown as a negative value.
1 LY	<b>OUT 1- output ratio limit or OUT 4</b>	0...100 % (ex works: 100)
2 LY	<b>OUT 2- output ratio limit or OUT4</b>	0...100 % (ex works: 100) Only: heating-off-cooling configuration. A limitation of the output ratio is only necessary when: <ul style="list-style-type: none"> <li>- the heating or cooling energy supply is grossly over-dimensioned compared to the power required, or</li> <li>- to turn off a control output (setting = 0%).</li> </ul> Under normal circumstances no limitation is needed (setting = 0%). The limitation becomes effective, when the controllers' calculated output ratio is greater than the maximum permissible (limited) ratio. <b>Warning!</b> The output ratio limitation does not work during autotune.
1 P	<b>OUT 1 - prop. band (P) or OUT 4</b>	OFF; 0,1...100,0 % (ex works: 3,0) if $X_p = \text{OFF}$ , the next parameter to follow is „1 Sd“ = control sensivity OUT 1
1 d	<b>OUT 1- rate (D) or OUT 4</b>	OFF; 1...200 secs (ex works: 30)
1 J	<b>OUT 1- reset (I) or OUT 4</b>	OFF; 1...1000 secs (ex works: 150) Normally the controller works using PD/I control action. This means, controlling without deviation and with practically no overshoot during start-up. The control action can be altered in its structure by making the following adjustments to the parameters: <ol style="list-style-type: none"> <li>a. no control action, on-off (setting P = OFF)</li> <li>b. P-action (setting D and I = 0)</li> <li>c. PD-action (setting I = 0)</li> <li>d. PI-action (setting D = 0)</li> <li>e. PD/I modified PID-action</li> </ol>
1 CY	<b>OUT 1- cycle time heating</b>	0,5...240,0 secs (ex works: 10,0) The switching frequency of the actuator can be determined by adjusting the cycle time. This is the total time needed for the controller to switch on and off once. OUT 1: Relay outputs: cycle time > 10 secs OUT4: Bistable voltage outputs: cycle time 0,5...10 secs OUT4: Continuous outputs: no function

Display  
"Process"

Parameter

Display  
„Set“

**1 Sd control sensivity heating OUT1  
or OUT4**

Only if 1 P = OFF :

OFF; 0,1... 80,0 °K  
OFF; 0,01... 8,00 °K

(ex works: 0,1)

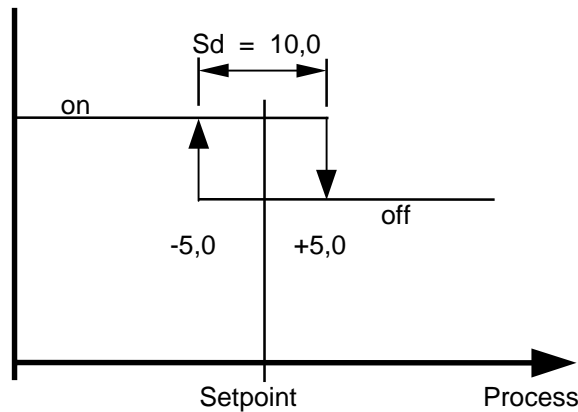

The following parameters apply only to the configuration of heat-cool controllers:

<b>Sh</b>	<b>switch-point difference</b>	OFF; 0,1...80,0 °K OFF; 0,01...8,00 °K This parameter raises the setpoint (switch-point) for cooling output by the displayed value. It can be help to reduce the switching frequency between the heating and cooling outputs, if this is to high. Simultaneously activation of heat and cool outputs is not possible.	(ex works: OFF)
<b>2 P</b>	<b>OUT2 / OUT4- cooling prop.-band (P)</b>	OFF; 0,1...100,0 % if Xp = OFF, the next parameter to follow is „2 Sd“ = control sensivity OUT 2	(ex works: 6,0)
<b>2 d</b>	<b>OUT2 / OUT4 - cooling rate (D)</b>	OFF; 1...200 secs	(ex works: 150)
<b>2 J</b>	<b>OUT2 / OUT4 - cooling reset (I)</b>	OFF; 1...1000 secs	(ex works: 15,0)
<b>2 CY</b>	<b>OUT2 / OUT4 - cooling cycle time</b>	0,5...240,0 secs	(ex works: 10,0)
Only if 2 P = OFF :			
<b>2 Sd</b>	<b>control sensivity cooling</b>	OFF; 0,1...80,0 °K OFF; 0,01...8,00 °K	(ex works: OFF)

**Opt self tuning**

see next pages please

Display "Process"	Parameter	Display „Set“
<b>OPt</b> self tuning (autotune)		OFF self tuning out of action on self tuning on request ( one time) Auto self tuning automatically if the controller is switched on and if the difference between process value and setpoint is > 7 % of the range.

The tuning algorithm determines the characteristic values within the controlled process, and calculates the valid feedback parameters ( P,D,I ) and the cycle time (  $C = 0.3 \times D$  ) of a PD/I-controller for a wide section of the range.

The determined parameters for heating are also adopted for cooling.

The self tuning activates during start-up shortly before the setpoint is reached. The setpoint must amount to the least 5% of the total range.

If activated after the setpoint has already been reached, the temperature will first drop by approx. 5% of the total range, in order to detect the exact amplification of the process.

The tuning algorithm can be activated at any time by selecting the OPT=on and pressing the „E“-key. During self tuning „Opt“ is shown in the display, alternating with the setpoint value.

Using the heat-cool controller, the temperature drop will be accelerated by switching on the cooling for a short duration.

After having calculated the correct feedback parameters, the controller will lead the process value to the setpoint.

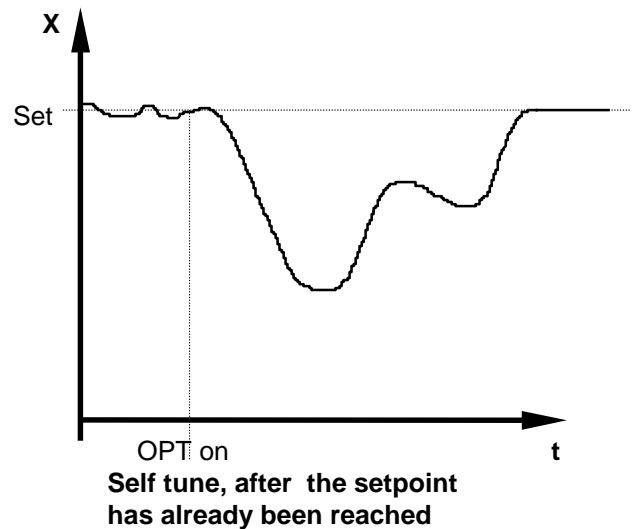
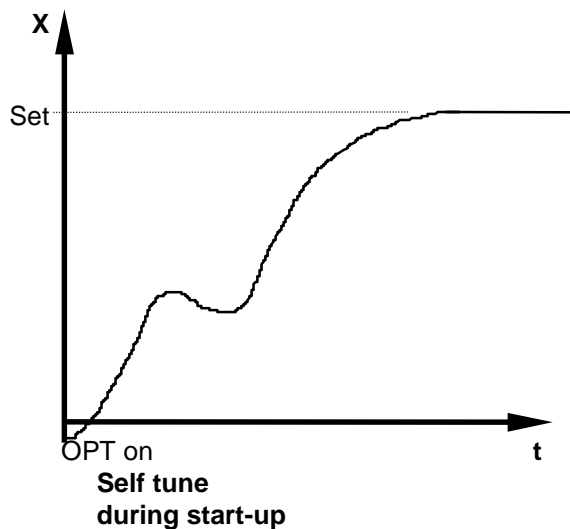

Self-tuning can be stopped by selecting the option OPT = OFF and pressing the „E“ - key.

<b>OFSt</b> process value offset	-999 ... OFF ...1000 °K	(ex works: OFF)
	-99,9 ... OFF ... 100,0 °K	

This parameter serves to correct the input signal, e.g. for:

- the correction of a gradient between the measuring point and the sensor tip,
- the line resistance balancing of 2-line RTD (Pt100) sensors and
- correction of the control deviation when using P- or PD-action.

If for example the offset value is set to +5°C, then the real temperature measured by the sensor (when process is balanced) is 5°C less than the setpoint and the displayed process value.

## Operating Level

Display "Process"	Parameter	Display "Set"
----------------------	-----------	---------------

---

**Process**  
(process)

and

<b>Setpoint 1</b> (set)	OFF, SP.Lo...SP.Hi	(ex works: 0)
----------------------------	--------------------	---------------

**are displayed simultaneously (basic setting).**

If setpoint 1 (SP1) is set to "OFF", the controller switches to stand-by.  
The setpoint display then shows "OFF". All main outputs are switched off and the alarm is de-activated.  
All parameters can be displayed and altered during stand-by.

<b>SP2 Setpoint 2</b>	OFF; SP.Lo SP.Hi	(ex works: OFF)
-----------------------	------------------	-----------------

The 2. setpoint is active when the external contact K1 is closed.  
The corresponding LED „SP2“ lights up on the faceplate, and the second set-point is shown in the display.“  
Please note, that the value of the second setpoint cannot be changed in the operating level.  
In order to change the value the parameter SP2 has to be selected.

<b>AL 3 Alarm 3, Out3</b>	signal contact, setpoint dependent	
	OFF; -999...1000 °K	(ex works)
	OFF; -99,9...100,0 °K	

limit comparator, setpoint dependent		
OFF; 1...1000 °K		(ex works)
OFF; 0,1...100,0 °K		

limit contact, process value dependent		
OFF; range bottom ... range top		

The range of adjustment is dependant on the sensor and the alarm configuration.  
Both have to be set in the configuration level.

<b>AL 2 Alarm 2, Out2</b>	for adjustments see „Alarm 3“ Alarm 2 is only available, if the controller is programmed as a 2-point- or a continuous-controller in the configuration-level.
---------------------------	--

## Error displays

<b>Display</b>	<b>Cause</b>	<b>Possible remedy</b>
SP.Lo	Lower setpoint limit has been reached	Reduce limit, if need be
SP.Hi	Upper setpoint limit has been reached	Increase limit, if need be
LOC	Parameter has been locked	Unlock, if need be
Hand	Instrument operates in manual mode Automatically switch over because of a sensor error (if this is programmed).	Check sensor and cable
Er.Hi	Top range end has been exceeded, sensor defect	Check sensor and cable
Er.Lo	Bottom range end has been exceeded, sensor defect	Check sensor and cable
Er.OP	Self tuning error	Extinguish error signal by pressing the „E“-key. Check the self tuning conditions and restart.
Er.SY	System error	Extinguish error signal by pressing the „E“-key. Check all parameters. If the error signal continues please send the controller back for examination.

## Installation Instructions

Make certain that the devices described here are used only for the intended purpose.

They are intended for installation in control panels.

The controller must be installed so that it is protected against impermissible humidity and severe contamination.

In addition, make sure that the permitted ambient temperature is not exceeded.

**The electrical connections must be made according to the relevant locally applicable regulations.**

If using a thermocouple sensor, the compensation cables must be laid directly to the controller terminals.

Transducers must be connected only in compliance with the programmed range.

Transducer cables and signal lines (e.g. logic or linear voltage outputs) must be laid physically separated from control lines and mains voltage supply cables (power cables).

To keep the CE-conformity it is necessary, to use for sensor- and low voltage signal lines shielded cables.

Spatial separation between controller and inductive loads is recommended.

Interference from contactor coils must be suppressed by connecting adapted RC-combinations parallel to the coils.

Control circuits (e.g. for contactors) should not be connected to the mains power supply terminals of the controller.

**IMPORTANT:**

Before operation, the unit must be configured for its intended purpose

(e.g. controller type, sensor type and range, alarm adjustment etc.). Please see „Configuration Level“.

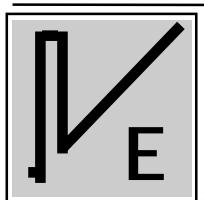

**ELOTECH Industrieelektronik GmbH**

**Verbindungsstr. 27**

**D – 40723 Hilden**

**Tel. 02103 / 23055 Fax. 02103 / 23057**

**Internet <http://www.elotech.de>**

## Parameter Adjustments

<b>1. Configuration level:</b>	<b>Ex works:</b>	<b>Customers adjustments:</b>
ConF Controller Configuration	2P h (heat-only)	
Out4 Configuration Output OUT4	OFF	
SEn Sensor Configuration	P4 °C (0.400°C, RTD)	
rA.SP decimal points	not displayed	
rA.Hi display range top end	not displayed	
rA.Lo display range bottom end	not displayed	
SP.Hi Upper Setpoint Limitation	400	
SP.Lo Lower Setpoint Limitation	0	
Co.A3 Alarm 3-Configuration	OFF	
Co.A2 Alarm 2-Configuration	OFF	
So.Y Softstart output ratio	OFF	
So.SP Softstart setpoint	not displayed	
So.ti Softstart duration ime	not displayed	
HAnd Auto-/Manual operation	OFF	
Co.c1 Function of external contact k1	Loc	
LOC Adjustment lock	OFF	
1140 Control number: EL.xx	read only	
<b>2. Parameter level:</b>	<b>Ex works:</b>	<b>Customers adjustments:</b>
Y Actual output ratio	read only	
1 LY OUT 1/4- Output ratio limitation	100,0	
2 LY OUT 2- Output ratio limitation	not displayed	
1 P OUT 1/4- Proportional band (P)	3,0	
1 d OUT 1/4- Rate (D)	30	
1 J OUT 1/4- Reset time (I)	150	
1 CY OUT 1/4- Output cycle time	15,0	
1 Sd OUT 1/4- Control sensivity	not displayed	
Sh Switch-point difference	not displayed	
2 P OUT 2- Proportional band (P) „cooling“	not displayed	
2 d OUT 2- Rate (D) „cooling“	not displayed	
2 J OUT 2- Reset time (I) „cooling“	not displayed	
2 CY OUT 2- Output cycle time „cooling“	not displayed	
2 Sd OUT 2- Control sensivity „cooling“	not displayed	
OPt Self tuning	OFF	
OFSt Process value offset	OFF	
<b>3. Operating level:</b>	<b>Ex works:</b>	<b>Customers adjustments:</b>
Actual process value (process)	read only	
Setpoint (set)	OFF	
SP2 Setpoint 2	OFF	
AL3 Alarm point 3	OFF	
AL2 Alarm point 2	OFF	