



ELOTECH
INDUSTRIELELEKTRONIK GMBH

R 1300: Microprocessor-based Multifunctional Controller



DIN-Format: 96 x 96 mm
Installation depth: 122 mm

Description And Operating Manual

No.: R1300-EN-98

03/2000

Contents

Typ code	Page	2
Connection diagram		3
Technical data		4
Display and keyboard		5
Operating levels		6
Configuration level		7
Parameter level		13
Operating level		17
Error displays		19
Installation instructions		19

Please read this operating manual carefully before starting up.

Observe the installation and connecting instructions.

Type Code

R 1300 - x - 00 - z



- 1: Power supply: 230 VAC (internal jumper : 115 V ac)
- 2: Power supply: 115 VAC (internal jumper : 230 V ac)
- 3: Power supply: 24 VAC
- 2: Power supply: 24 VDC , +/- 20%

- 1: OUT1, OUT2: Relay and bistab. voltage output for 2-point-, 3-point- and 3-point-step-controller
- 2: OUT1, OUT2: Relay and bistab. voltage output for 2-point-, 3-point- and 3-point-step-controller
 OUT4, continuous: Controller output: 0/4...20mA, 0/2...10 VDC to control "heating" or "cooling"
 Ser. Interface: RS 485 (RS232 upon request)
- 3: OUT1, OUT2: Relay and bistab. voltage for 2-point-, 3-point- and 3-point-step-controller
 OUT4, continuous: Programmable: Controller output 0/4...20mA, 0/2...10 VDC
 Process value output 0/4...20mA, 0/2...10 VDC
 Setpoint value output 0/4...20mA, 0/2...10 VDC
 OUT5, continuous: Programmable: Controller output 0/4...20mA, 0/2...10 VDC
 Process value output 0/4...20mA, 0/2...10 VDC
 Setpoint value output 0/4...20mA, 0/2...10 VDC
 Ser. Interface: RS 485 (RS232 upon request)
 Analog. Setpoint-Input: 0/4...20mA, 0...10 VDC

Connection Diagram

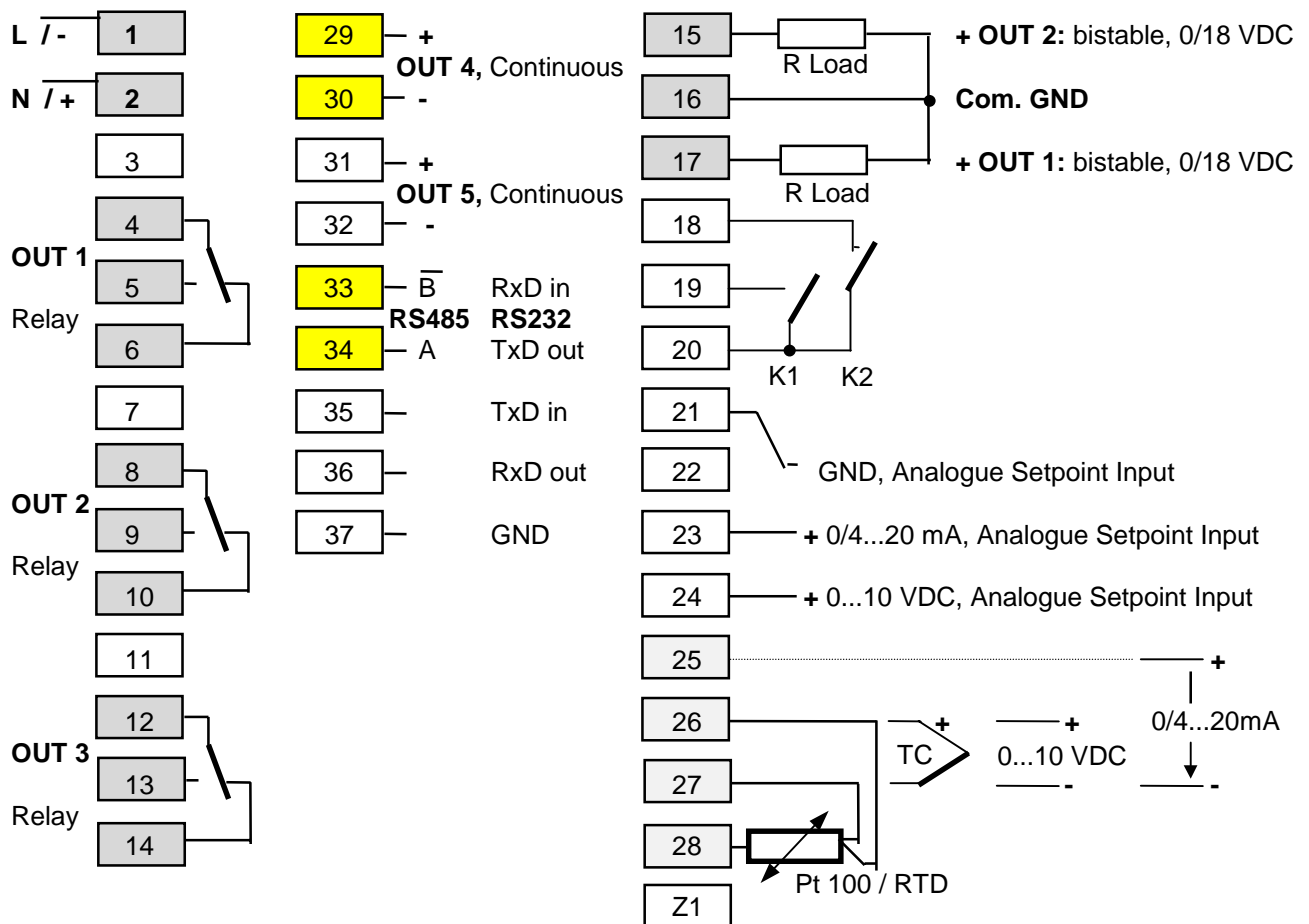

It is not permitted to connect the grounds of the sensor-, bist. voltage- and continuous-outputs with each other. RTD 2-wire connection: jumper between terminals 27 and 26.

OUT1: Control output	2-point-controller: "Heating" e.g „Cooling“ 3-point-controller: „Heating“ 3-point-step-controller: „On“
OUT2: Control output or alarm output	2-point-controller: Alarm 2 3-point-controller: „Cooling“ 3-point-step-controller: „Off“
OUT3: Alarm Output	Alarm 3
OUT4: Continuous Output	R1300-2: Controller Output R1300-3: Function: See Configuration Level. Controller output or analogue process value output or analogue setpoint output
OUT5: Continuous Output	R1300-3: Function: See Configuration Level. Controller output or analogue process value output or analogue setpoint output
Setpoint Controlling:	K1: open = Setpoint 1 (SP1) valid K1: closed = Depends of the configuration (see Parameter Co.SP): Setpoint 2 (SP2) or external, analog Setpoint value (SPA) valid
Adjustment lock (LOC):	K2: open = Adjustment lock only via "Software Code" K2: closed.= Adjustment locked (according to the chosen Software Code)

Technical Data

Input Thermocouple:	Built-in internal compensation point and protection against sensor breakage and incorrect polarity. Re-calibration not required for a line resistance of up to 50 Ohms. Calibration accuracy: $\leq 0,25\%$
Input RTD, Pt 100 (DIN):	2- or 3- wire connection possible. Built-in protection against sensor breakage and short circuit. Max. permissible line resistance by 3-wire connection: 80 Ohms Sensor current: $\leq 0,5$ mA Calibration accuracy: $\leq 0,2 \%$
Linear error:	$\leq 0,2 \%$
Influence of the ambient temperature:	$\leq 0,01 \%$ / K
Setpoint selection:	Ext. potential-free contact, switching voltage appr. 24 V dc, max. 1 mA. Selection between SP1 and SP2 or between SP1 and the analogue setpoint signal SPA.
Control outputs:	
-OUT 1:	Relay (UR appr.), (changeover contact) max. 250 Vac, max. 3 A (cos-phi = 1) and bist. voltage signal, 0/18 V dc, max. 10 mA, short-circuit proof
-OUT 2:	Relay (UR appr.), (changeover contact) max. 250 Vac, max. 3 A (cos-phi = 1) and bist. voltage signal, 0/18 V dc, max. 10 mA, short-circuit proof
-OUT 4 or OUT 5:	Continuous (version \geq R1300-2) The output signal (current or voltage) is determined automatically, dependand on load. 0/4...20 mA, load of max. 500 Ohm 0/2...10 V dc, load of > 1 k-Ohm Linearity: $\leq 1,5 \%$ Delay time: app. 2 secs.
Alarm output:	
-OUT 2:	Relay (UR appr.), (changeover contact) max. 250 Vac, max. 3 A (cos-phi = 1). Only for 2-point-controller and continuous-controller configuration.
-OUT 3:	Relay (UR appr.), (changeover contact) max. 250 Vac, max. 3 A (cos-phi = 1).
Setpoint input: (analogue)	(Only version R1300-3), equivalent to the choosen range 0...10 V dc 0...20 mA 4...20 mA
Process output: (analogue)	-OUT4 or OUT5: (Only version R1300-3), equivalent to the choosen range 0...10 V dc 0...20 mA 4...20mA Load max. 500 Ohms
Ser. Interface:	(\geq version R1300-2) RS 485, Protokoll: Standard (RS232: Option)
7-Segment-Display:	Process: 10 mm red, Set: 10 mm red
Data protection:	EAROM
EMC:	Tested according to 89 / 336 / EEC EN 50081-2, EN 50082-2
Power supply:	230 V ac, (internal jumper 115 V ac). Others possible. See Type Code. $\pm 10 \%$, 48...62 Hz
Connections:	Screw terminals (UR appr.). Protection mode IP 20 (DIN 40050), Insulation class C.
Permissible operating conditions:	Operating temperature: 0...50 °C / 32...122 °F Storage temperature: -30...70 °C / -22...158 °F Climate class: KWF DIN 40040; equivalent to annual average max. 75 % rel. humidity, no condensation
Casing:	Format: 96 x 96 mm (DIN 43700), installation depth 122 mm Panel cutout: 92 +0,5 mm x 92 +0,5 mm Material: Noryl, self-extinguishing, non-drip, UL 94-V1 Protection mode: IP 20 (DIN 40050), IP 50 front side
Weight:	app. 650g (R1300-1); app. 800g (R1300-2, R1300-3)

Subject to technical improvements!



Display and Keyboard

Display PROCESS : Process Value
 Display SET : Setpoint Value

LED OUT 1: Output OUT1 active: Control Output
 LED OUT 2: Output OUT2 active: Control Output or Alarm Output A2
 LED OUT 3: Output OUT3 active: Alarm Output A3

LED  : Setpoint ramp active

LED SP2 : Setpoint 2 active



Parameter key



Adjustment of chosen parameter (e.g. setpoint) to higher or lower values.



Short operation: single-step adjustment
 Longer operation: quick-scanning
 When the parameter adjustments have been altered but not entered, the display will flash bright/dark.



Confirmation and storage of the pre-selected values
 The display will shortly be switched dark as a control of this function.

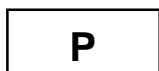

Sets the parameter back to the originally stored value.
 Any alterations made to the parameters, that are not confirmed (E-key) within 30 seconds, will not be accepted and the parameter will return to its originally stored value.

Operating Levels

The operation of the controller is divided into three levels.

Two seconds after switching on the unit, the controller will automatically be in the operating level.

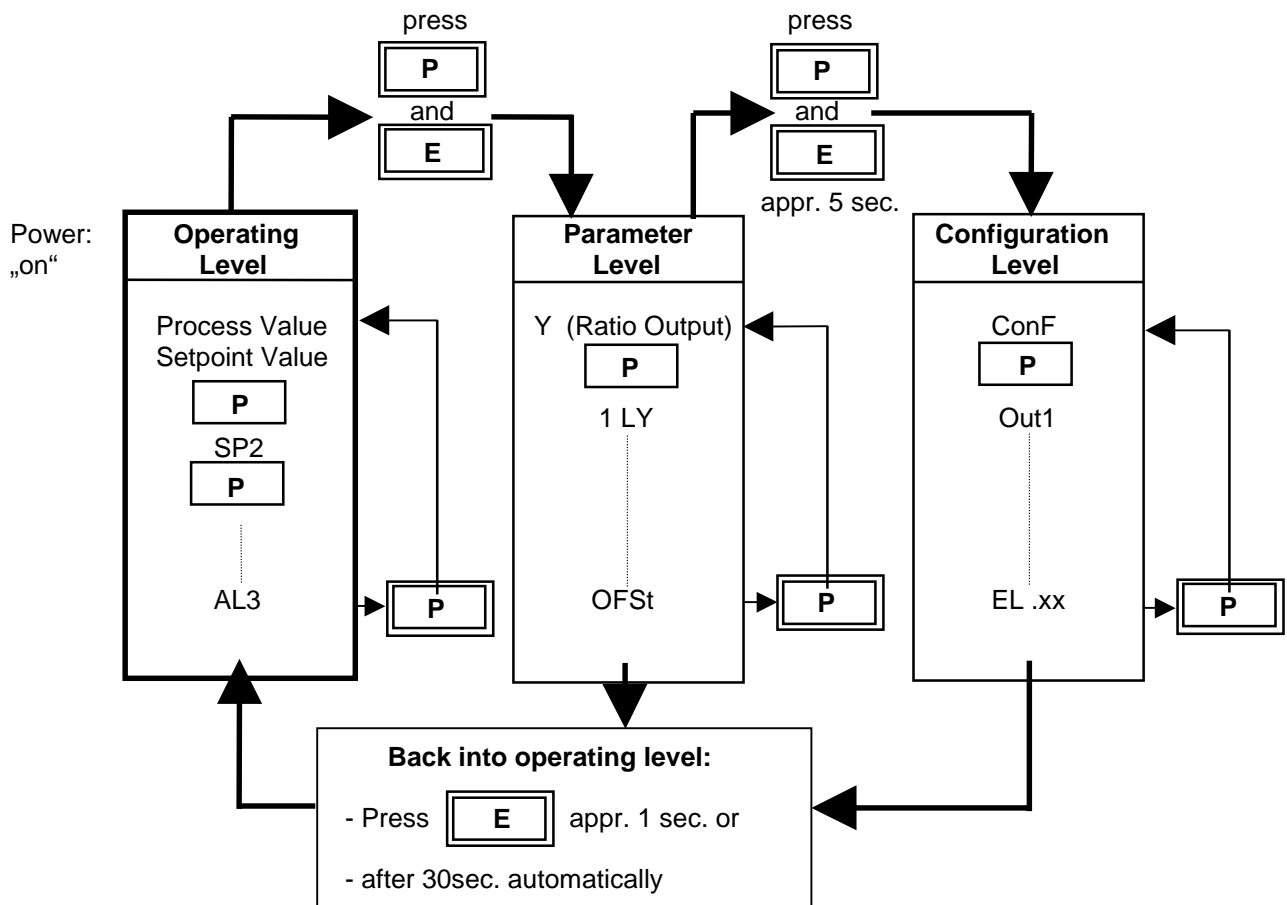

Operating level

Process- and Setpoint value will be displayed simultaneously.

Within the operating level the setpoints, the setpoint-ramp and the alarm value can be adjusted by pressing the "▲" / "▼" - keys.

Every adjustment has to be quit by pressing the „E“ - key.

All parameters within the operating level can, in succession, be displayed by pressing the „P“ - key and adjusted by pressing the "▲" / "▼" - keys.

Parameter level

Within the parameter level the values are adjusted to suit each individual process.

This level is reached by simultaneously pressing the "P" - and "E" -keys.

Configuration level

In the configuration level the controller type, input type, sensor range, alarm behaviour and the output type can be pre-selected.

This primary information has to be entered before taking the controller into operation.

The configuration level is reached by simultaneously pressing the "P" - and "E" - keys for a period of approx. 5 seconds.

The display of each single parameter within the parameter and configuration levels, and their adjustment, are made in the same fashion as within the operating level.

After either pressing the „E“ - key for approx. 1 second, or waiting for a period of approx. 30 seconds, the unit will automatically return to the operating level (display of process value and setpoint).

Display "Process"	Parameter	Display „Set“				
SEn	Sensor selection	P1 °C	Pt 100,	-50,0...100,0	°C	
		P1 °F	Pt 100,	-58,0...212,0	°F	
		P2 °C	Pt 100,	-90,0...205,0	°C	
		P2 °F	Pt 100,	-130...401	°F	
		P3 °C	Pt 100,	0,0...300,0	°C	
		P3 °F	Pt 100,	32...572	°F	
		P4 °C	Pt 100,	0...400	°C (ex works)	
		P4 °F	Pt 100,	32...752	°F	
		P8° C	Pt 100,	0...800	°C	
		P8 °F	Pt 100,	32...1472	°F	
		L4 °C	T/C Fe-CuNi (L),	0...400	°C	
		L4 °F	T/C Fe-CuNi (L),	32...752	°F	
		L8 °C	T/C Fe-CuNi (L),	0...800	°C	
		L8 °F	T/C Fe-CuNi (L),	32...1472	°F	
		J8 °C	T/C Fe-CuNi (J),	0...800	°C	
		J8 °F	T/C Fe-CuNi (J),	32...1472	°F	
		n1 °C	T/C NiCr-Ni (K),	0...1200	°C	
		n1 °F	T/C NiCr-Ni (K),	32...2192	°F	
		S1 °C	T/C Pt10Rh-Pt (S),	0...1600	°C	
		S1 °F	T/C Pt10Rh-Pt (S),	32...2912	°F	
			0 - 20	Current	0...20	mA
			4 - 20	Current	4...20	mA
			10 dc	Voltage	0...10	V dc

If the Sensor selection is changed, the following parameters will be reset (setting in brackets) and need to be re-adjusted:

All Setpoints (OFF); ramps (OFF); alarm value (OFF); control sensivity (0); process offset(OFF); lower setpoint limitation (SP.Lo); higher setpoint limitation (SP.Hi).

The following parameters are only valid for standard signal inputs (0...20mA, 4...20mA, 0...10Vdc). The difference between the bottom end of the display range and the top end must amount to a minimum of 100 units and a maximum of 2000 units. By adjustment of one of the above parameters, the other in this case will automatically follow.

rA.SP	decimal points	0; 1; 2	(ex works: 1)
rA.Hi	display range top end	rA.Lo ... 9999	(ex works: 100,0)
rA.Lo	display range bottom end	-1999 ... rA.Hi	(ex works: 0,0)

Only version R1300-3:

Sc.Hi	higher indication range limitation (20mA, 10 VDC)	valid for the analogue setpoint in- and outputs and the analogue process value output.
Sc.Lo	lower indication range limitation (0/4mA, 0/2 VDC)	valid for the analogue setpoint in- and outputs and the analogue process value output.

The difference between the bottom end of the range and the top end must be an amount to a minimum of 25% percent of the measuring range.

SP.Hi **higher setpoint limitation** Valid for the analogue input and the keyboard adjustments.
programming range: SP.Lo ... top range (ex works: 400)

SP.Lo **lower setpoint limitation** Valid for the analogue input and the keyboard adjustments.
programming range: bottom range ... SP.Hi (ex works: 0)

Display
"Process"

Parameter

Display
„Set“

Co.A3 Alarm 3-Configuration
(OUT 3)

OFF
1
2
3
4
5
6
7

alarm OFF, no alarm signalisation (ex works)
signal contact: off-on
limit contact: off-on
limit comparator: off-on-off
signal contact: on-off
limit contact: on-off
limit comparator: on-off-on
limit comp. with start-up suppression: off-on-off

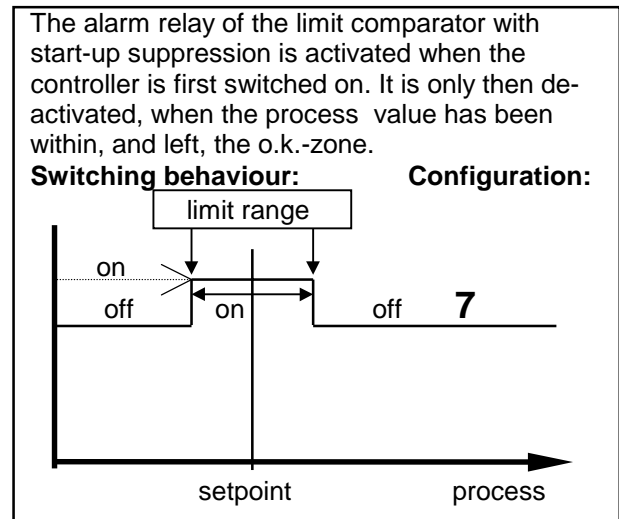
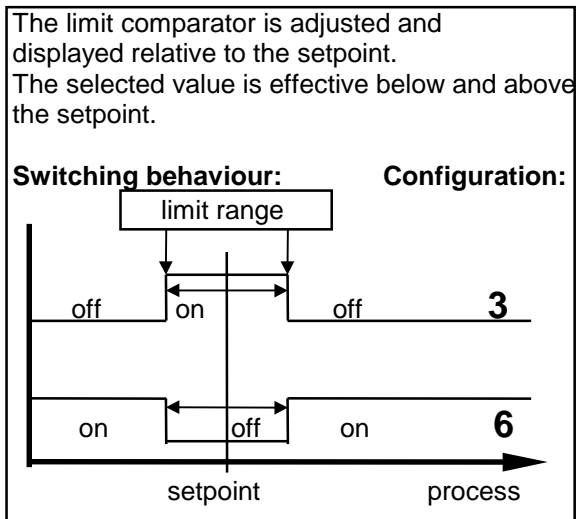
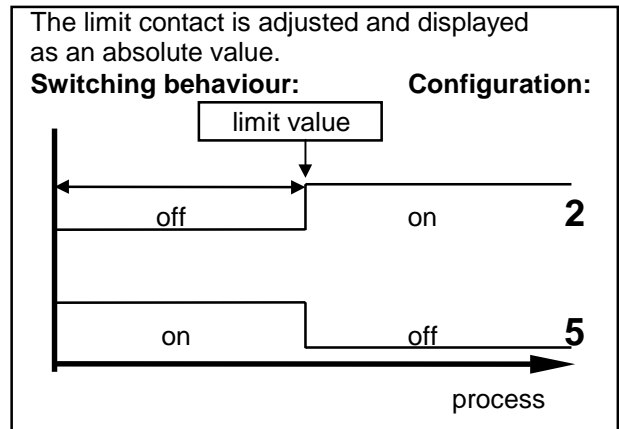
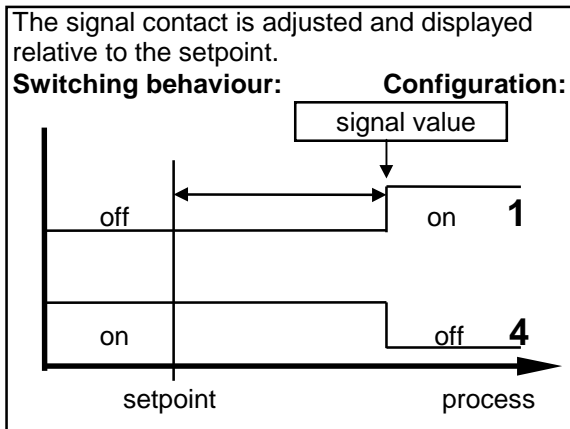

on: Relay "activated" or bistable voltage output "high".
off: Relay "not active" or bistable voltage output "low".

If a setpoint ramp has been programmed, the alarms that are relative to the setpoint (signal contact, limit comparator) follow the setpoint up the ramp.

Please note:

In case of sensor error the alarms will react in the same way as range override.
The alarm contacts therefore do not offer protection against all types of plant breakdown.
With this in mind, we recommend the use of a second, independent monitor unit.

Co.A2 Alarm 2-Configuration see Co.A3 (alarm 3 - configuration)
(switches OUT 2)

Only for 2-point- (heat-only) , 3-point-(heating mode) and continuous- (heating) controller configurations:

Softstart (general function):

Temperature

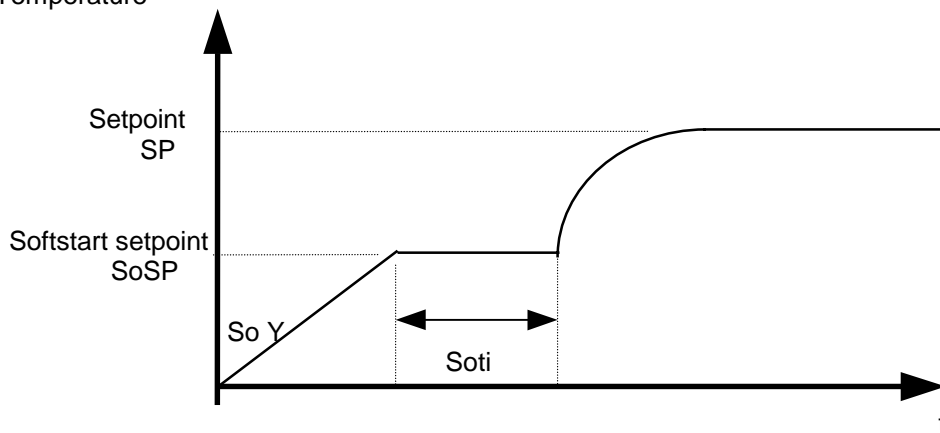

During the softstart the controllers' output response is limited to a pre-selected ratio, in order to achieve a slow baking out of high performance heat cartridges. Simultaneously the output clock frequency is quadrupled. Once the process value reaches the softstart setpoint, it remains stable at this value for a pre-selected hold-duration time. At the end of this period the process value rises to the valid setpoint. This results in a slower, more regular heating period.

For this purpose the bistable voltage output must be chosen, that actuates SSR relays.

If the softstart is active, the controllers' autotune function can't operated (Er.OP).

If a setpoint-ramp has been programmed, the softstart has priority, and the ramp will only become active after the softstart has been completed.

The softstart only works, if the parameter „1 P“ (prop. band, xp) is programmed > 0,1%.

So.St	Softstart	OFF: Softstart not active (ex works) Next parameter So.Y, So.SP, So.ti are not shown.	
		On: Softstart in action.	
So.Y	Softstart output ratio	10 ... 100%	(ex works: 10%)
So.SP	Softstart setpoint	range: SP.Lo SP.Hi	(ex works: 0)
So.ti	Softstart duration time	OFF; 0,1 ... 9,9 min.	(ex works: OFF)

Display "Process"	Parameter	Display „Set“
Hand	manual output ratio	OFF (ex works) Auto Man <u>Setting: OFF</u> not active <u>Setting: Auto</u> In event of sensor break the controller automatically maintains the last valid output ratio as the actuating signal. An „H“ is then displayed as the first digit in the setpoint display, followed by the valid output ratio. This ratio can be manually altered in steps of 1% (up/down-keys; enter). Under the following circumstances, the output ratio will be 0%: - if the output ratio at time of the sensor break was 100%. - if the controller is working along a setpoint-ramp. - if the control deviation was more than 0,25% of the total range at the time of sensor break. - if the prop. band (P; xp) = 0. - if the soft start was active at the time of the sensor break. A few seconds after the sensor break has been rectified, the controller returns to automatic operation and calculates the required output ratio. An additional signal can be issued in the event of sensor break, if the alarm contacts are programmed accordingly. <u>Setting: MAn</u> The controller now operates only as an actuator. Within the operation level, an output ratio can be entered instead of the setpoint. An „H“ is then displayed as the first digit in the setpoint display, followed by the output ratio. There is no controlling action.

Only ≥ version R-1300-3:

Co.SP Setpoint selection

- SP2 Setpoint setting controlled by the external contact K1
setpoint 2 valid, if K1 is closed (ex works)
- SPA.0 external, analogue setpoint valid, if K1 is closed.
setpoint signal: 0...20mA corresp. to the range.
- SPA.4 external, analogue setpoint valid, if K1 is closed.
setpoint signal: 4...20mA corresp. to the range
- SPA.U external, analogue setpoint valid, if K1 is closed.
setpoint signal: 0...10 Vdc corresp. to the range

Display "Process"	Parameter	Display „Set“
----------------------	-----------	------------------

Co.Sb	Sensor break	This parameter is only available when the controller is configured as a 3-point-step-controller. Behaviour in event of sensor break:		
	OFF	OUT1: off;	OUT2: off	(ex works)
	OUT2	OUT1: off	OUT2: on	
	OUT1	OUT1: on	OUT2: off	

LOC	Adjustment lock	OFF	no adjustment lock (ex works)
		P C	parameter and configuration levels locked
		n.SP1	all parameters apart from SP1 locked (not SP1)
		ALL	all parameters locked

All parameters that have been locked with „LOC“ can be selected and read, but not altered.
This adjustment cannot be changed if the external contact K2 is closed.

The following parameters are only valid, if the unit is equipped with a serial interface.
Only \geq version R-1300-2:

Adr	Unit adress	1 255	(ex works: 1)
		The computer addresses the unit at this adress. Each unit has ist own adress. It is possible to adress 32 units.	
For	Data format	7E1	7 data, even, 1 stopbit
		7o1	7 data, odd, 1 stopbit
		7E2	7 data, even, 2 stopbit
		7o2	7 data, odd, 2 stopbit
		7n2	7 data, none, 2 stopbit
		8E1	8 data, even, 1 stopbit
		8o1	8 data, odd, 1 stopbit
		8n1	8 data, none, 1 stopbit
		8n2	8 data, none, 2 stopbit
bAud	Baud rate	OFF; 0,3 ... 38,4 kBaud	(ex works: 9,6)
		The baud rate denotes the transmission rate at which one bit is transmitted.	

See interface-description: SST1300E

EL.xx	Control number	end of configuration level
--------------	-----------------------	----------------------------

Parameter Level		
------------------------	--	--

Display "Process"	Parameter	Display „Set“
Y	valid output ratio	-100...100 % The output ratio shows the momentary calculated ratio. It cannot be altered. The display is in percent of the installed performance capability for heating or cooling. Output ratio for cooling is shown as a negative value.
1 LY	OUT 1- output ratio limit OUT 4	0...100 % (ex works: 100)
2 LY	OUT 2- output ratio limit OUT 5	0...100 % (ex works: 100) Only: heating-off-cooling configuration. A limitation of the output ratio is only necessary when: - the heating or cooling energy supply is grossly overdimensioned compared to the power required, or - to turn off a control output (setting = 0%). Under normal circumstances no limitation is needed (setting = 0%). The limitation becomes effective, when the controllers' calculated output ratio is greater than the maximum permissible (limited) ratio. Warning! The output ratio limitation does not work during autotune.
1 P	OUT 1 - prop. band (P) OUT 4	OFF; 0,1...100,0 % (ex works: 3,0) if Xp = OFF, the next parameter to follow is „1 Sd“ = control sensitivity OUT 1
1 d	OUT 1- rate (D) OUT 4	OFF; 1...200 secs (ex works: 30)
1 J	OUT 1- reset (I) OUT 4	OFF; 1...1000 secs (ex works: 150) Normally the controller works using PD/I control action. This means, controlling without deviation and with practically no overshoot during start-up. The control action can be altered in its structure by making the following adjustments to the parameters: a. no control action, on-off (setting P = OFF) b. P-action (setting D and I = OFF) c. PD-action (setting I = OFF) d. PI-action (setting D = OFF) e. PD/I modified PID-action
1 CY	OUT 1- cycle time heating OUT 4	0,5...240,0 secs (ex works: 10,0) The switching frequency of the actuator can be determined by adjusting the cycle time. This is the total time needed for the controller to switch on and off once. a) Relay outputs: cycle time > 10 secs b) Bistable voltage outputs: cycle time 0,5...10 secs c) Continuous outputs: cycle time 0,5 secs

Display
"Process"

Parameter

Display
„Set“

The following parameters apply only to the configuration of 3-point-step-controllers:

P	xp, prop.-band (P)	OFF; 0,1...200,0 %		(ex works: 10,0)
tS	Motor, actuating time	5 ... 800 secs		(ex works: 40)
tn	reset time (I)	0,5 ... 80,0 min.		(ex works: 3,0)
Sd	control sensivity	OFF; 0,1...80,0 OFF; 0,01...8,00 OFF; 0,001...0,800	units units 1) units 2)	(ex works: OFF)
Sh	dead band	OFF; 0,1...80,0 units OFF; 0,01...8,00 OFF; 0,001...0,800	units 1) units 2)	(ex works: OFF)

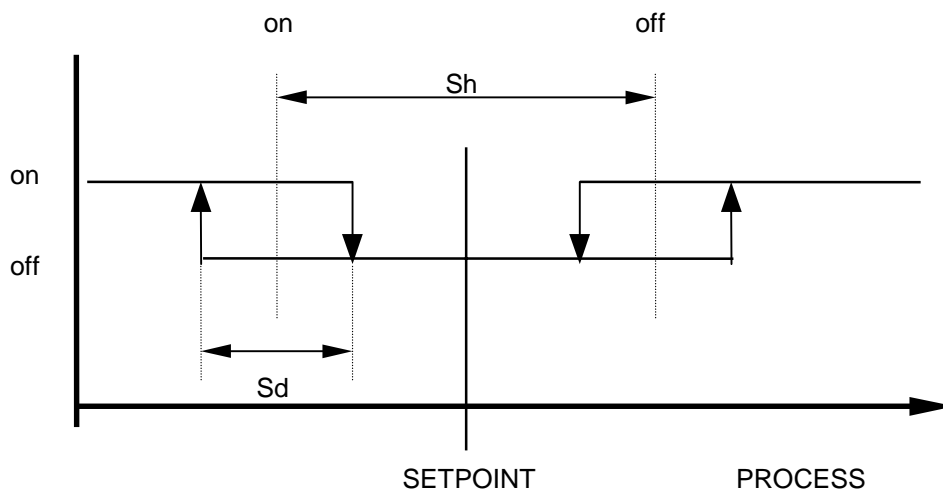

3-point-step-controllers use PI control action in combination with motor actuators. It is important, that SH should be several times larger than Sd. Switching frequency is dependant on the pre-selected feedback values.

Display "Process"	Parameter	Display „Set“
OPt	self tuning (autotune)	OFF self tuning out of action on self tuning on request (one time) Auto self tuning automatically if the controller is switched on and if the difference between process value and setpoint is > 7 % of the range.

The tuning algorithm determines the characteristic values within the controlled process, and calculates the valid feedback parameters (P,D,I) and the cycle time ($C = 0.3 \times D$) of a PD/I-controller for a wide section of the range.

The determined parameters for heating are also adopted for cooling.

The self tuning activates during start-up shortly before the setpoint is reached. The setpoint must amount to the least 5% of the total range.

If activated after the setpoint has already been reached, the temperature will first drop by approx. 5% of the total range, in order to detect the exact amplification of the process.

The tuning algorithm can be activated at any time by selecting the OPT=on and pressing the „E“-key. During self tuning „Opt“ is shown in the display, alternating with the setpoint value.

Using the heat-cool controller, the temperature drop will be accelerated by switching on the cooling for a short duration.

After having calculated the correct feedback parameters, the controller will lead the process value to the setpoint.

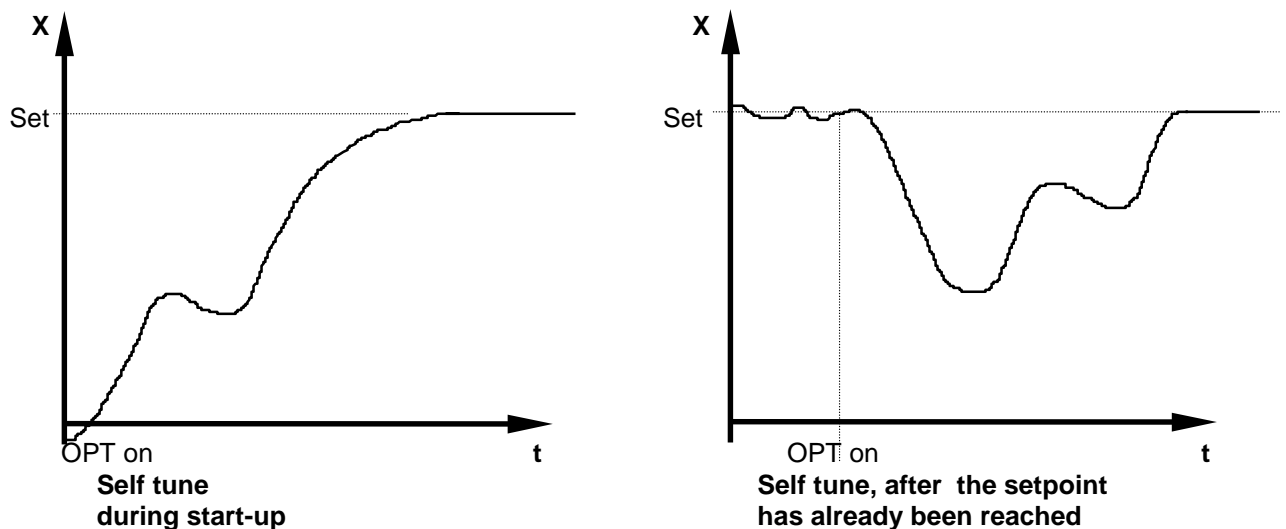

Self-tuning can be stopped by selecting the option OPT = OFF and pressing the „E“ - key.

OFSt	process value offset	-999 ... OFF ...1000 Units	(ex works: OFF)
		-99,9 ... OFF ... 100,0	1)
		-9,99 ... OFF ... 10,00	2)

This parameter serves to correct the input signal, e.g. for:

- the correction of a gradient between the measuring point and the sensor tip,
- the line resistance balancing of 2-line RTD (Pt100) sensors and
- correction of the control deviation when using P- or PD-action.

If for example the offset value is set to +5°C, then the real temperature measured by the sensor (when process is balanced) is 5°C less than the setpoint and the displayed process value.

Operating Level

Display	Parameter	Display "Set"
---------	-----------	---------------

"Process"

Process
(process)

and

Setpoint 1 OFF, SP.Lo...SP.Hi 4) (ex works: 0)
(set)

are displayed simultaneously (basic setting).

If setpoint 1 (SP1) is set to "OFF", the controller switches to stand-by.
The setpoint display then shows "OFF". All main outputs are switched off and the alarm is de-activated.
All parameters can be displayed and altered during stand-by.

SP2 Setpoint 2 OFF; SP.Lo SP.Hi 4) (ex works: OFF)

The 2. setpoint is active when the external contact K1 is closed.

The corresponding LED „SP2“ lights up on the faceplate, and the second set-point is shown in the display.“

Please note, that the value of the second setpoint cannot be changed in the operating level.
In order to change the value the parameter SP2 has to be selected.

SP \uparrow rising ramp OFF; 0,1...100,0 units/min. (ex works: OFF)
OFF; 0,01 ... 10,00 units/min. 1)
OFF; 0,001 ... 1,000 units/min. 2)

SP \downarrow falling ramp OFF; 0,1...100,0 units/min. (ex works: OFF)
OFF; 0,01 ... 10,00 units/min. 1)
OFF; 0,001 ... 1,000 units/min. 2)

A programmed ramp is always activated when the setpoint is altered or when the mains supply is switched on. The ramp constructs itself out of the momentary process value and the pre-selected setpoint. If the ramp is active, the corresponding LED lights up on the faceplate. The ramp can be activated for both setpoint1 and setpoint2.
By programming the second setpoint accordingly a setpoint profile can be obtained (please see example below).

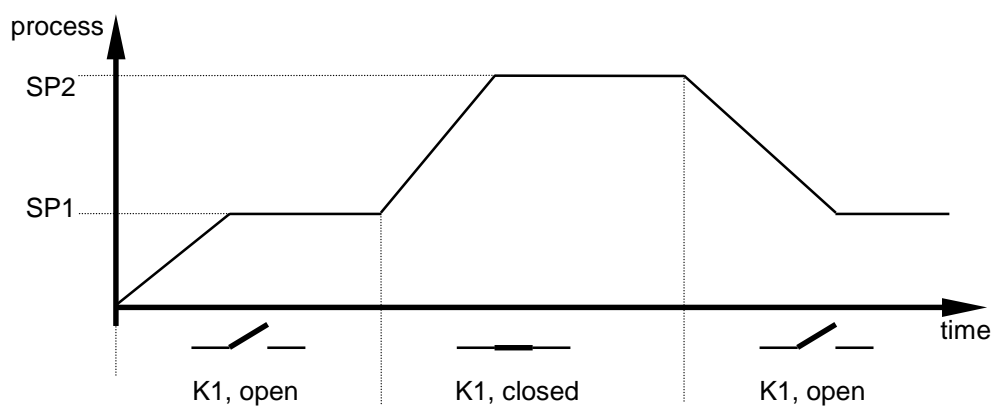

Error displays

Display	Cause	Possible remedy
SP.Lo	Lower setpoint limit has been reached	Reduce limit, if need be
SP.Hi	Upper setpoint limit has been reached	Increase limit, if need be
rA.Lo	Bottom range end has been reached (for standard signal inputs)	Reduce limit, if need be
rA.Hi	Top range end has been reached (for standard signal inputs)	Increase limit, if need be
LOC	Parameter has been locked	Unlock, if need be
Hand	Instrument operates in manual mode Automatically switch over because of a sensor error (if this is programmed).	Check sensor and cable
Er.Hi	Top range end has been exceeded, sensor defect	Check sensor and cable
Er.Lo	Bottom range end has been exceeded, sensor defect	Check sensor and cable
Er.SP	Analogue setpoint error, upper or lower value has been reached	Check setpoint signal and cable
Er.OP	Self tuning error	Extinguish error signal by pressing the „E“-key. Check the self tuning conditions and restart.
Er.SY	System error	Extinguish error signal by pressing the „E“-key. Check all parameters. If the error signal continues please send the controller back for examination.
Notes:	1) valid for ranges with one decimal point 2) valid for ranges with two decimal points 4) SP.Lo = lower setpoint limitation SP.Hi = upper setpoint limitation	

Installation Instructions

Make certain that the devices described here are used only for the intended purpose.
They are intended for installation in control panels.
The controller must be installed so that it is protected against impermissible humidity and severe contamination.
In addition, make sure that the permitted ambient temperature is not exceeded.

The electrical connections must be made according to the relevant locally applicable regulations.

If using a thermocouple sensor, the compensation cables must be laid directly to the controller terminals.
Transducers must be connected only in compliance with the programmed range.
Transducer cables and signal lines (e.g. logic or linear voltage outputs) must be laid physically separated from control lines and mains voltage supply cables (power cables). They must be shielded.
Spatial separation between controller and inductive loads is recommended.
Interference from contactor coils must be suppressed by connecting adapted RC-combinations parallel to the coils.
Control circuits (e.g. for contactors) should not be connected to the mains power supply terminals of the controller.

IMPORTANT:

Before operation, the unit must be configured for its intended purpose
(e.g. controller type, sensor type and range, alarm adjustment etc.). Please see „Configuration Level“.

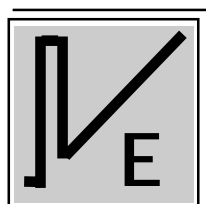

ELOTECH Industrieelektronik GmbH
Verbindungsstr. 27
D – 40723 Hilden
Tel. 02103 / 23055 Fax. 02103 / 23057
Internet <http://www.elotech.de>