

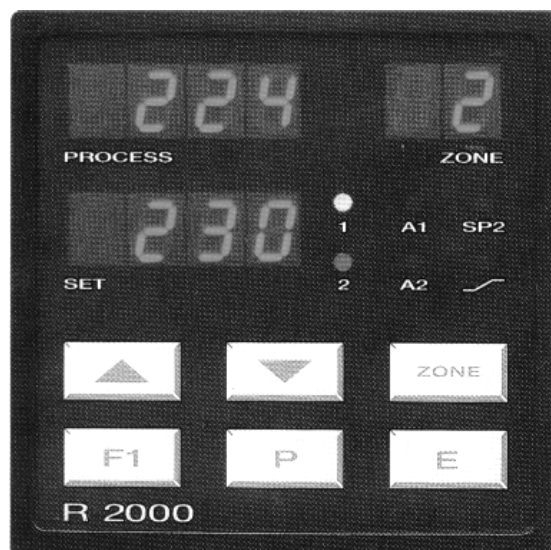

ELOTECH
INDUSTRIELELEKTRONIK GMBH

R2000 - B2 2 - Zones Temperature Controller

2 x Heating - Off or
2 x Heating - Off - Cooling or
1 x Heating - Off and 1 x Heating - Off - Cooling



Format: 96 x 96 mm (1/4-DIN)
Installation depth: 67 mm

DESCRIPTION AND OPERATING MANUAL

3.2 2 x heating-off-cooling controller (3-point controller)

Attention: Terminal 3 (\perp) has to be connected with a very short and big cable to earth potential (switching cabinet) !

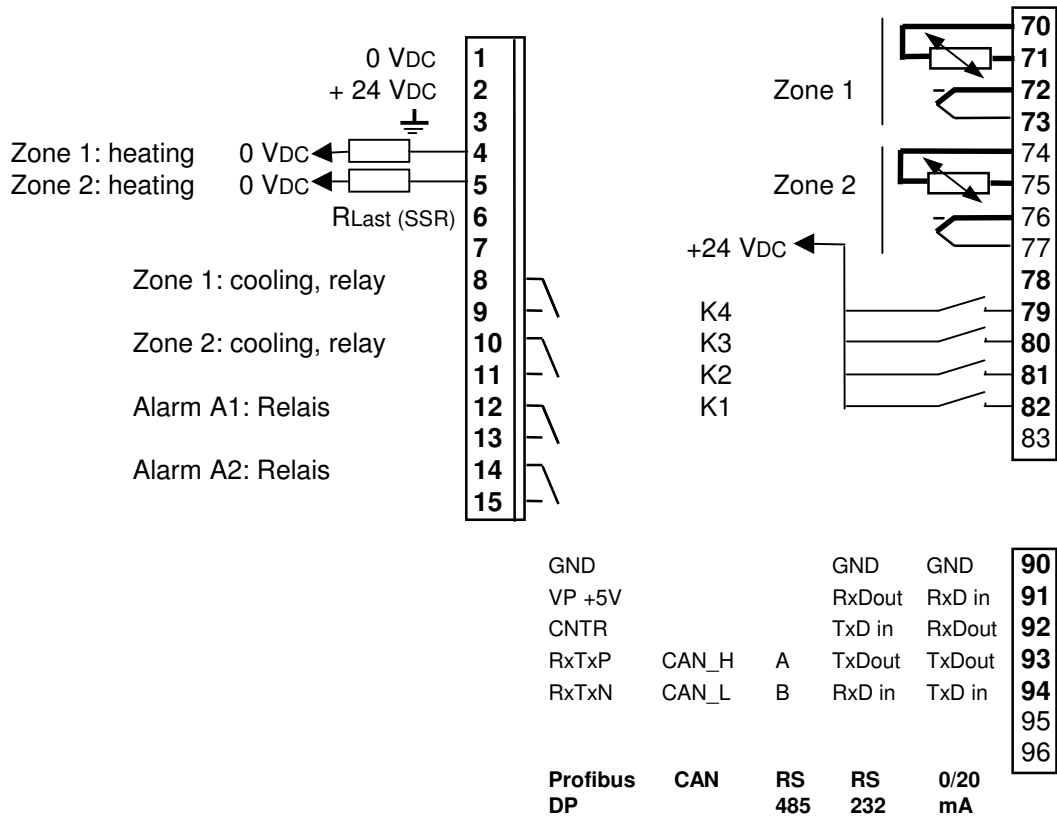

- Alarm Output A1:** Alarm 1 (Temperature-monitoring alarm A1 for both zones)
Alarm Output A2: Alarm 2 (Temperature-monitoring alarm A2 for both zones)
- Setpoint Controlling:** K1: open = Setpoint 1 (SP1) valid
 K1: closed = Setpoint 2 (SP2) valid, for both zones
- Adjustment lock (LOC):** K2: open = Adjustment lock only via „software code“
 K2: closed = Adjustment locked according to the choosen „software code“.
- Setpoint changing:** K3: open = individual setpoint adjustment for each zone
 K3: closed = if setpoint has been changed in one zone, this new setpoint is valid (will be overtaken) for the other zone automatically.
- CAN-Interface:** K4: open = CAN: „operational“. Operation only with CANopen protocoll.
 K4: closed = CAN: „operational“ always active.
 *) „K4“ must be closed, if the instrument is equipped with a CAN-interface but not used.

4. Display and Keyboard

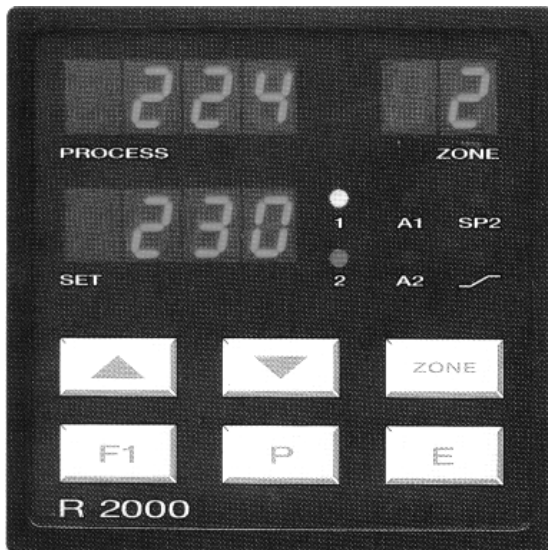

LED 1: Control output "heating" active
LED 2: Control output "cooling" active

LED A1: Alarm 1 activ
LED A2: Alarm 2 activ

LED SP2: Setpoint 2 valid
LED : Ramp function activ

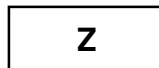

Zone preselection



Parameter key (parameter preselection)



Adjustment of chosen parameter (e.g. setpoint) to higher or lower values.



Short operation: single-step adjustment
Longer operation: quick-scanning
When the parameter adjustments have been altered but not entered with the "E"-key, the display will flash bright/dark.



Confirmation and storage of the pre-selected values.
The display will show a light chain as a control of this function.
Press 2 sec. to go back to the actual temperature and setpoint indication.

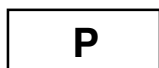

Sets the parameter back to the originally stored value.
Any alterations made to the parameters, that are not confirmed (E-key) within 30 seconds, will not be accepted and the parameter will return to its originally stored value.

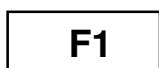

Function key, E. g. both zones are displayed cyclic (zone scanning on/off).
Zones, which are not in action (OFF), are not displayed.
The function of this key can be programmed into the configuration level of zone 0. See parameter „Co.F1“.

5. Tendency Display

After switching the instrument „on“ a temperature tendency display will be shown, to give an overview about the temperatures deviations relating to the setpoints in the individual controller zones.

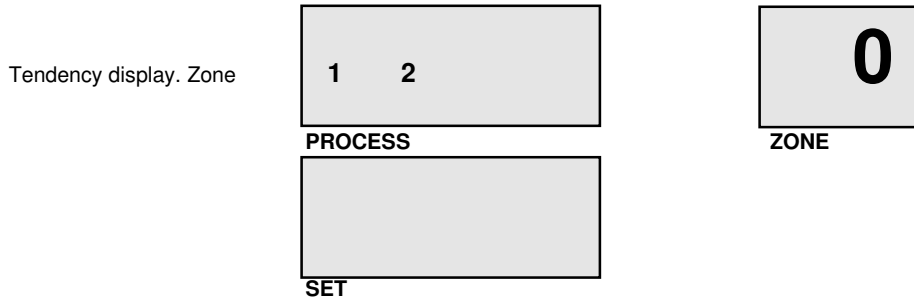

Symbols displayed in display „PROCESS“:

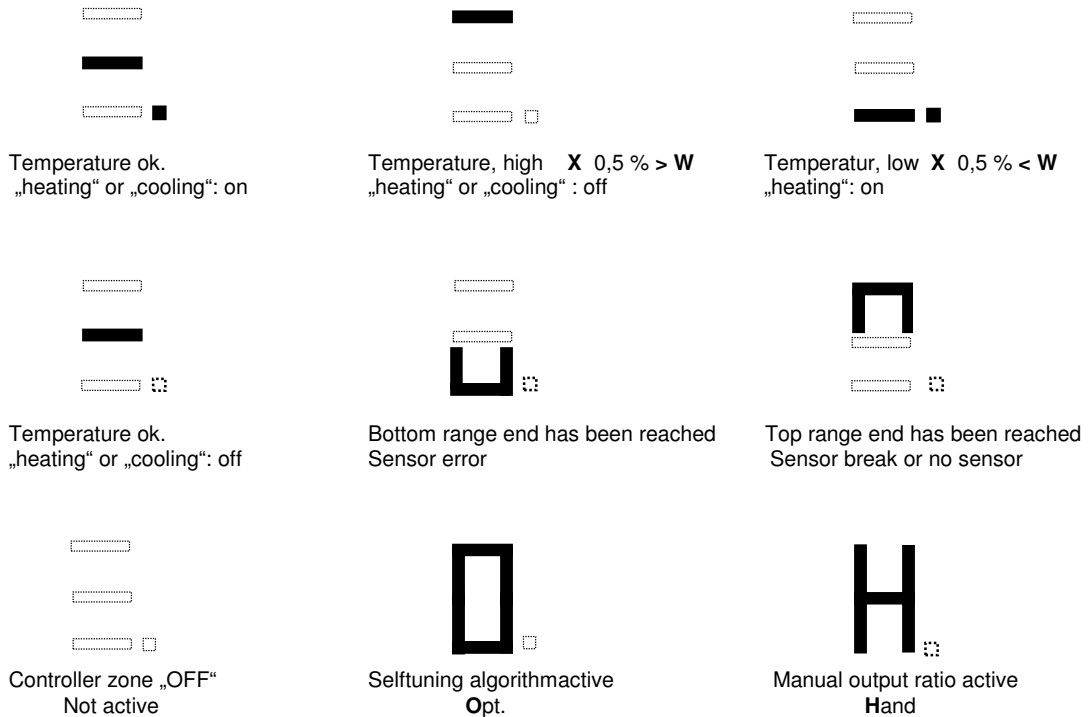

Attention: Dec.-point (on the right of the digit) flashing acc. to the actual output ratio „heating“ or „cooling“.
Flashing segments: alarm signalisation in the concerning zone

Zone scanning: Now (according to the configuration of key „F1“) the process and setpoint values of both zones are shown in a scanning mode.
If „F1“ is not configured in this mode (see configuration level) , the individual zones have to be selected manual by pressing key „ZONE“.

6. Operating Levels

The operation of the controller is divided into 3 levels.

After switching on the unit, it will be automatically in the operating level.

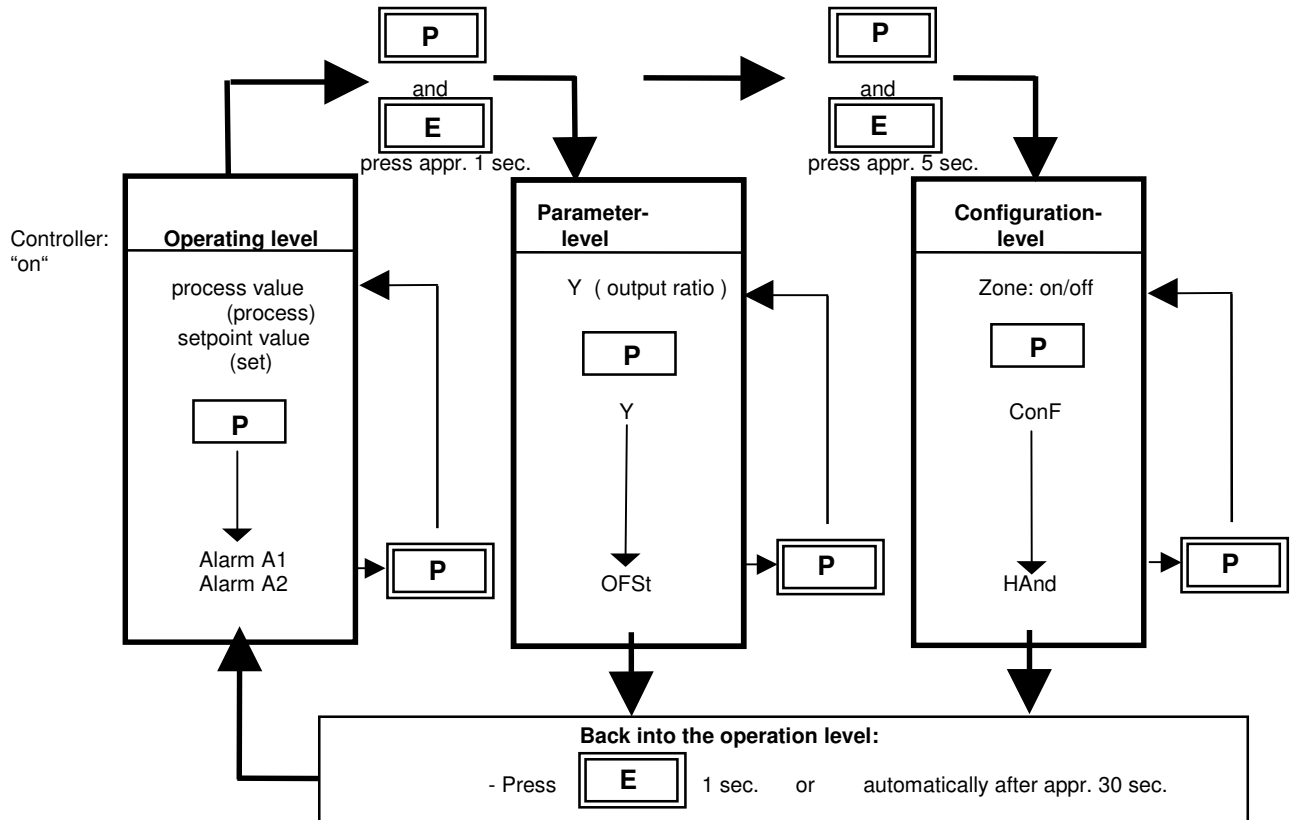

Operating level:

Process- and Setpoint value will be displayed simultaneously. Setpoint 2 and alarm values will be preselected.

Within the operating level the setpoint can be adjusted by pressing the "▲"/"▼" - keys.

Every adjustment has to be quit by pressing the „E“ - key.

All parameters within the operating level can, in succession, be displayed by pressing the „P“ - key and adjusted by pressing the "▲"/"▼" - keys.

Parameter level:

Within the parameter level the values are adjusted to suit each individual process.

This level is reached by simultaneously pressing the "P" - and "E" - keys.

The display of each single parameter within the parameter level and their adjustment, are made in the same fashion as within the operating level.

After either pressing the „E“ - key for approx. 1 second, or waiting for a period of approx. 30 seconds, the unit will automatically return to the operating level (display of process value and setpoint).

Configuration level; select zone 0 :

This primary informations have to be entered before taking the instrument into operation.

Here the general settings (concerning zone 1 and zone 2) have to be made.

The configuration level is reached by simultaneously pressing the "P" - and "E" - keys for a period of approx. 5 seconds.

- Sensor selection (RTD or Thermocouple)
- Alarm configuration
- Software key
- Function of key „F1“
- Serial interface informations

Configuration level; select zone 1 or zone 2 :

The configuration level is reached by simultaneously pressing the "P" - and "E" - keys for a period of approx. 5 seconds.

- Controller configuration (for each zone)
- Min. and max. setpoint range (for each zone)
- Input type (sensor type), sensor range (for each zone)

After either pressing the „E“ - key for approx. 1 second, or waiting for a period of approx. 30 seconds, the unit will automatically return to the operating level (display of process value and setpoint).

7. Configuration Level, general adjustments for zone 1 and zone 2

(Select Zone 0 and press keys „P“ and „E“ appr. 5 sec.)

Display "PROCESS"	Parameter	Adjustments or adjustment range „SET“
P - tc	Sensor connection	tc Zone 1 and 2: Thermocouple connection Pt Zone 1 and 2: RTD (Pt100) connection
Co.A1	Alarm 1-Configuration (switches relay A1)	OFF alarm OFF, no alarm signalisation (ex works) 1 signal contact, setpoint dependent: off-on 2 limit contact, process value dependent: off-on 3 limit comparator: off-on-off 4 signal contact: on-off 5 limit contact: on-off 6 limit comparator: on-off-on 7 limit comp. with start-up suppression: off-on-off

Please note: Each alarm contact works as a collecting contact for both zones.

The selected configuration is effective for all control zones.

The individual temperature alarms A1 of all zones are connected to the main, common contact A1.

If a control zone indicates a fault (sensor short circuit / break), the alarm output A1 is switched.

In case of sensor error the alarms will react in the same way as range override. The alarm contacts therefore do not offer protection against all types of plant breakdown. With this in mind, we recommend the use of a second, independent monitor unit.

Care should be used to ensure, that the setpoints of the alarm contacts are programmed within the selected measuring range. If a setpoint ramp has been programmed, the alarms that are relative to the setpoint (signal contact, limit comparator) follow the setpoint up the ramp.

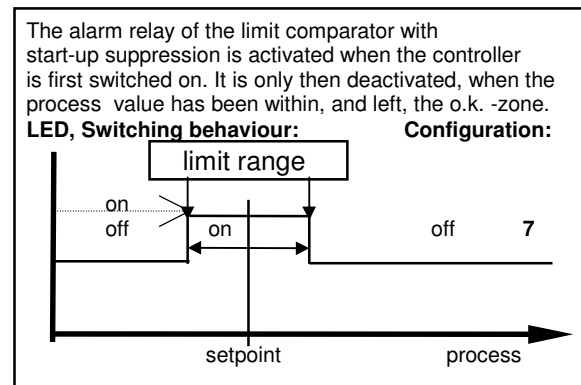
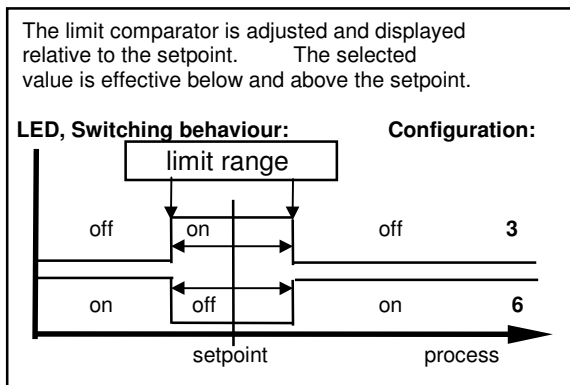
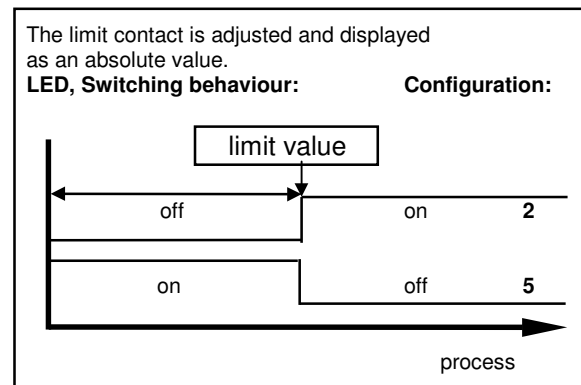
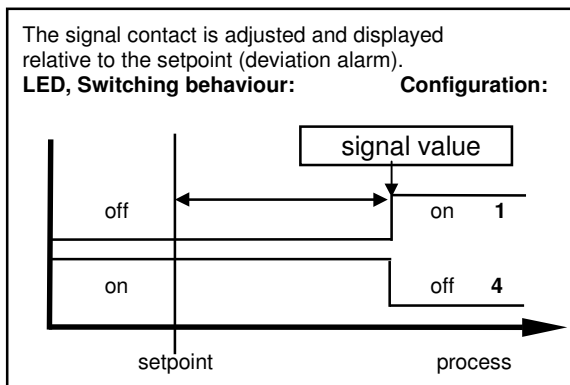

"PROCESS"

„SET“

rE.A1	Relay A1 switching behaviour	dir	on: LED A1 „on“. off: LED A1 „off“.	Relay A1 "activated" Relay A1 "not active"
		inv	on: LED A1 „on“. off: LED A1 „off“.	Relay A1 "not active", Relay A1 "activated",
Co.A2	Alarm 2-Configuration (switches relay A2)	see Co.A1 (alarm 1 - configuration)		
rE.A2	Relay A2 switching behaviour	dir	on: LED A2 „on“. off: LED A2 „off“.	Relay A1 "activated" Relay A1 "not active"
		inv	on: LED A2 „on“. off: LED A2 „off“.	Relay A1 "not active", Relay A1 "activated",
Co.F1	Select funktion of key „F1“	OFF	No function	
		OPt	Selftuning algorithm can be activated by pressing key „F1“ in the matching zone. „F1“ and „E“: stop selftuning.	
		Y	Shows the actual percentage output ratio, while pressing „F1“.	
LOC	Adjustment lock	LEd.t	LED test. While pressing „F1“ all LED are „on“.	
		OFF	No adjustment lock (ex works)	
		P C n.SP1 ALL	Parameter and configuration levels locked All parameters apart from SP1 locked (not SP1) All parameters locked All parameters that have been locked with „LOC“ can be selected and read, but not altered.	
contact			This adjustment cannot be changed if the external K2 is closed.	
Zo.OF	Zones offset: preselection (Continuous numbering of the controller zones)	OFF 1 - 97	No offset preselection. Zones indication: 1 and 2 Zones will be numbered with preselected offset value. Example: Zo.OF = 1 -> Zone indication: 2 and 3 Zo.OF = 4 -> Zone indication: 5 and 6	

Display "PROCESS"	Parameter	Adjustments or adjustment range „SET“
----------------------	-----------	------------------------------------------

The following parameters are only valid, if the unit is equipped with a serial interface.
RS232, RS485, 0/20mA.

Prot	Protocol preselection	ELO	ELOTECH- standard protocol
Adr	Unit address	1 255	(ex works: 1) The computer addresses the unit/controller at this address. Each unit has ist own address. With RS-485 it is possible to adress 32 units.
For	Data format	7E1 7o1 7E2 7o2 7n2 8E1 8o1 8n1 8n2	7 data, even, 1 stopbit 7 data, odd, 1 stopbit 7 data, even, 2 stopbit 7 data, odd, 2 stopbit 7 data, none, 2 stopbit 8 data, even, 1 stopbit 8 data, odd, 1 stopbit 8 data, none, 1 stopbit 8 data, none, 2 stopbit (ex works: 7E1)
bAud	Baud rate	OFF; 0,3 ... 9,6 kBaud	(ex works: 9,6) The baud rate denotes the transmission rate at which one bit is transmitted.
	Details:	See sep. interface description: ELOTECH – standard-protocol	

The following parameters are only valid, if the unit is equipped with a CAN interface.

Adr	Unit address	1 127	(ex works: 1)
bAud	Baud rate	10, 20, 50, 100, 125, 250, 500 kBaud, 1MBaud	(ex works: 20)
	CANopen-specification:	CANopen Master: CANopen Slave: Extended Boot-up: Minimum Boot-up: COB ID Distribution: Node ID Distribution: No. of POD's: PDO Modes: Variable PDO mapping: Emergency message: Life guarding: No. of SDO's: Device Profile:	no yes no yes yes; default via SDO no; via device keyboard 0RX, 1TX async. no yes yes 1RX, 1TX CiA DS-404
	Details:	See CANopen Device Profile CiA DS-404; ELOTECH Object Dictionary	

Display "PROCESS"	Parameter	Adjustments or adjustment range „SET“
----------------------	-----------	------------------------------------------

The following parameters are only valid, if the unit is equipped with a **PROFIBUS DP – interface** (acc. EN50170).

Note: Only in PROFIBUS-technologie trained personnel following the safety regulations may do the PROFIBUS - connections.
It is essential, that one has well experience in installing a Profibus-device.

This allows to set and to read the process- and configuration-datas by a higher level computer (here called: master). The communication is always controlled by the master.
The controller operates as a slave with its own adress and different zones.

rEMo	remote operation	off	Profibus: read only Controller operation via the keyboard is possible.
		on	Profibus: read / write It is only possible to programm and operate the controller via the Profibus DP – interface (no operation via keyboard). Parameter „remote“ has to be set to „on“. Otherwise it is not possible to write datas into the device.
Adr	device adress	1 125	(ex works: 1) There are up to 32 device addresses in one segment programable. With the help of a repeater up to 127 devices can be connected. The single controller zones are called up within the protocol.
bAud	baud rate	The baud rate will be detected and displayed automatically. It is not adjustable.	
		ndEt	not detected
		12 n	12 MBaud
		6 n	6 MBaud
		3 n	3 MBaud
		1,5 n	1,5 MBaud
		500	500 kBaud
		187,5	187,5 kBaud
		93,75	93,75 kBaud
		45,45	45,45 kBaud
		19,2	19,2 kBaud (will not be supported)
		9,6	9,6 kBaud (will not be supported)

Interface: RS485. Twisted pair 2-wire connection. See EN 50170, Chapt. 2

Network-Topology: Linear bussystem with activ bus termination on both ends.
Spot lines are possible (depending of the used cable type): 3-12Mbit/sec. = max. lenght: 1,5m
1,5 Mbit/sec. = max. lenght: 6,5m

Connections: The terminals (signals) VP and GND only are to be used to connect the external terminating resistors. There are no further connections allowed.

Specials:

- Configuration channel für reading and writing of all available parameters.
- Configurable process data moduls.
- Diagnostic warnings, to detect sensor- and/or system errors.
- Easy connection to IPC`s or PLC`s.

Informations about the Profibus-communication: See Dec.-Point in display „ZONE“.

Dec.-point off: Profibus not connected or master not activ.

Dec.-point flashing: Master detected – Device expects parameter.

Dec.-point on: Data Exchange Modus

See: Elotech-Discription and Data transfer Profibus-DP
FAQ`s: www.elotech.de → Products → Technical Data

2xxx
EL.xx **Check sum** No function. End of Configuration level.

8. Configuration Level, individual adjustments for zone 1 and zone 2

(Select Zone 1 or 2 and press keys „P“ and „E“ appr. 5 sec.)

Display "PROCESS"	Parameter	Adjustments or adjustment range „SET“
Zone	Zone on / off	OFF measuring- or controller zone „off“ on measuring- or controller zone „on“
ConF	Controller configuration	2P h 2-point-controller „heating-off“ (ex works) 2P c 2point-controller „cooling-off“ 2Pnc 2point-controller „cooling-off“ with non-linear cooling *) 3P 3point-controller „heating-off-cooling“ 3Pnc 3point-controller „heating-off-cooling“ with non-linear cooling *) *) non-linear cooling: Cooling action can be pre-selected with either linear or non-linear cooling response curve (e.g. for vapour cooling). diSP Zone works as an indicator, no controller action
C.Out	Configuration of the controller output	If any controller zone is configured as a 2-point controller, one has to program the needed controller output . This happens with the help of parameter „C.Out“. rEL Controller output: relay (in this case the logic output is without function) biSt Controller output: bistable voltage signal (SSR control) (in this case the relay output is without function) If this controller zone is configured as a 3-point controller, the parameter „C.Out“ will not be shown. In this case (general):heating = bist. logic output cooling = relay output
SEn	Sensor selection	If RTD (Pt100) input is selected: P1 °C Pt 100, -50,0...100,0 °C P1 °F Pt 100, -58,0...212,0 °F P2 °C Pt 100, -90,0...205,0 °C P2 °F Pt 100, -130... 401 °F P4 °C Pt 100, 0... 400 °C (ex works) P4 °F Pt 100, 32... 752 °F P8 °C Pt 100, 0... 800 °C P8 °F Pt 100, 32...1472 °F If thermocouple-input is selcted: L4 °C T/C Fe-CuNi (L), 0... 400 °C L4 °F T/C Fe-CuNi (L), 32... 752 °F L8 °C T/C Fe-CuNi (L), 0... 800 °C L8 °F T/C Fe-CuNi (L), 32... 1472 °F J8 °C T/C Fe-CuNi (J), 0... 800 °C J8 °F T/C Fe-CuNi (J), 32... 1472 °F n1 °C T/C NiCr-Ni (K), 0... 1200 °C n1 °F T/C NiCr-Ni (K), 32... 2192 °F S1 °C T/C Pt10Rh-Pt (S), 0... 1600 °C S1 °F T/C Pt10Rh-Pt (S), 32... 2912 °F

If the Sensor selection is changed, the following parameters will be set as follows and need to be re-adjusted:

Setpoint 1, setpoint 2:	SP.Lo	Process value offset:	OFF
Lower setpoint limitation:	Bottom range end;	Higher setpoint limitation:	Top range end;
Setpoint-ramp values:	OFF;	Alarm values:	OFF;

SP.Hi higher setpoint limitation programming range: SP.Lo ... top range (ex works: 400)

SP.Lo lower setpoint limitation programming range: bottom range ... SP.Hi (ex works: 0)

Display "PROCESS"	Parameter	Adjustments or adjustment range „SET“
----------------------	-----------	------------------------------------------

Softstart-function

TAKE CARE: If you take the softstart-function, make sure that the heating control outputs are equipped with bistable voltage (logic) outputs.
This function is not allowed for relay-outputs, because the relays will be destroyed.

Softstart (general function):

During the softstart the controllers' heating output response is limited to a pre-selected ratio, in order to achieve a slow baking out of high performance heat cartridges.

Simultaneously the output clock frequency is quadrupled. Once the process value reaches the softstart setpoint, it remains stable at this value for a pre-selected hold-duration time.

At the end of this period the process value rises to the valid setpoint.

This results in a slower, more regular heating period.

For this purpose the bistable voltage output must be taken, that actuates SSR relays.

If the softstart is active, the controllers' autotune function can't operated (Er.OP).

If a setpoint-ramp has been programmed, the softstart has priority, and the ramp will only become active after the softstart has been completed.

The softstart only works,

- if the parameter „1 P“ (prop. band, xp) is programmed > 0,1%.

- if the actual process value is lower than So.SP – 5% of the selected measuring range.

It is possible, to select this function for each zone individually.

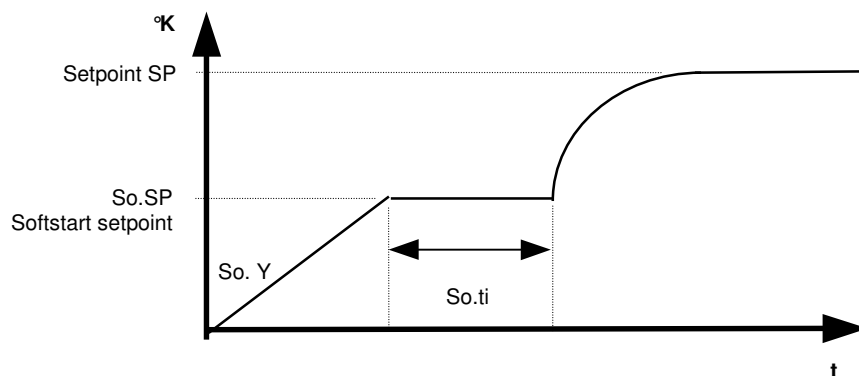

So.St	Softstart-function	OFF: Softstart not active (ex works) Next parameter So.Y, So.SP, So.ti are not shown. On: Softstart in action. The softstart function always runs, if the controller is switched on and / or if the actual temperature is below the softstart setpoint So.SP minus 5% of the range (e.g. range: 400°C -> 5%= 20°C).
So. Y	Softstart output ratio	10 ... 100%
So.SP	Softstart setpoint	adjustment range: SP.Lo SP.Hi
So.ti	Softstart duration time	OFF; 0,1 ... 9,9 min.

Display "PROCESS"	Parameter	Adjustments or adjustment range „SET“
Hand	manual output ratio	OFF, Auto, Man (ex works: OFF)

Setting: OFF

Function not active. Normal controller action.

Setting: Auto

In event of sensor break the controller automatically maintains the last valid output ratio as the actuating signal.

An „H“ is then displayed as the first digit in the setpoint display, followed by the valid output ratio. This ratio can be manually altered in steps of 1% (up/down-keys; enter).

Under the following circumstances, the output ratio will be 0%:

- if the output ratio at time of the sensor break was 100%.
- if the controller is working along a setpoint-ramp.
- if the control deviation was more than 0,25% of the total range at the time of sensor break.
- if the prop. band ($P; x_p$) = 0.
- if the soft start was active at the time of the sensor break.

A few seconds after the sensor break has been rectified, the controller returns to automatic operation and calculates the required output ratio of the controller.

An additional signal can be issued in the event of sensor break, if the alarm contacts are programmed accordingly.

Setting: Man

The controller now operates only as an actuator. Within the operation level, an output ratio can be entered instead of the setpoint.

An „H“ is then displayed as the first digit in the setpoint display, followed by the output ratio. There is no controlling action in this case.

9. Parameter Level, individual adjustments for zone 1 and zone 2

(select zone 1 or 2 and press „P“ - and „E“ - key appr. 1 sec.)

Display "PROCESS"	Parameter	Adjustments or adjustment range „SET“
Y	valid output ratio	-100...0...100 % (with CANopen-interface: 0,0...100,0) The output ratio shows the momentary calculated ratio. It cannot be altered. The display is in percent of the installed performance capability for heating or cooling. Output ratio for cooling is shown as a negative value.
1Y.Hi	output ratio limit „heating“	0...100 % (with CANopen-interface: 0,0...100,0) (ex works: 100) Limitation of the output ratio is only necessary when: the heating or cooling energy supply is grossly overdimensioned compared to the power required, or to turn off a control output (setting = 0%). Under normal circumstances no limitation is needed (setting = 0%). the limitation becomes effective, when the controllers' calculated output ratio is greater than the maximum permissible (limited) ratio. Warning! The output ratio limitation does not work during autotune.
2Y.Hi	output ratio limit „cooling“	0...100 % (with CANopen-interface: 0,0...100,0) (ex works: 100) Parameter is only shown, if heating-off-cooling action has been selected.
1 P	„heating“ prop. band (P)	OFF; 0,1...100,0 % (ex works: 3,0) If „1 P“ =OFF (control action: on-off, without feedback) next parameter is „1 Sd“.
1 d	„heating“ rate (D)	OFF; 1...200 secs (ex works: 30)
1 J	„heating“ reset (I)	OFF; 1...1000 secs (ex works: 150) Normally the controller works using PD/I control action. This means, controlling without deviation and with practically no overshoot during start-up. The control action can be altered in its structure by making the following adjustments to the parameters: a. no control action, on-off (setting P = OFF) b. P-action (setting D and I = 0) c. PD-action (setting I = 0) d. PI-action (setting D = 0) e. PD/I modified PID-action
1 C	„heating“ cycle time	0,5...240,0 secs (ex works: 10,0) The switching frequency of the actuator can be determined by adjusting the cycle time. This is the total time needed for the controller to switch on and off once. a) Relay outputs: cycle time > 10 secs b) Bistable voltage outputs: cycle time 0,5...10 secs
1 Sd	„heating“ Control sensitivity	Only if: 1 P = Xp = OFF (On-off action, without feedback) OFF; 0,1...80,0 °C (ex works: 0,1) OFF; 0,01 ... 8,00 °C (ranges with dec.point)

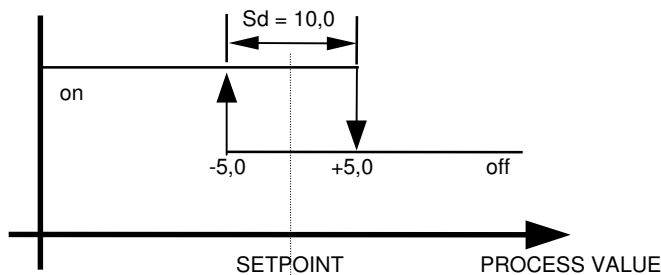

Display "PROCESS"	Parameter	Adjustments or adjustment range „SET“
----------------------	-----------	------------------------------------------

The following parameters are only displayed and valid if configuration is „ 3 P “ or „ 3 Pnc “. **Only for „heating-off-cooling“ action.**

Sh	switch-point difference	OFF; 0,1... 80,0 °C (ex works: OFF) OFF; 0,01... 8,00 °C (ranges with dec.-point) This parameter raises the setpoint (switch-point) for cooling output by the displayed value. It can be help to reduce the switching frequency between the heating and cooling outputs, if this is to high. Simultaneously activation of heat and cool outputs is not possible.
2 P	„cooling“ prop. band (P)	OFF; 0,1...100,0 % (ex works: 3,0) If „ 2 P “ = OFF (control action: on-off, without feedback) next parameter: „ 2 Sd “.
2 d	„cooling“ rate (D)	OFF; 1...200 secs (ex works: 30)
2 J	„cooling“ reset (I)	OFF; 1...1000 secs (ex works: 150)
2 C	„cooling“ cycle time	0,5...240,0 secs (ex works: 10,0) The switching frequency of the actuator can be determined by adjusting the cycle time. This is the total time needed for the controller to switch on and off once. a) Relay outputs: cycle time > 10 secs b) Bistable voltage outputs: cycle time 0,5...10 secs
2 Sd	„cooling“ Control sensitivity	Only if: 2 P = OFF (On-off action, without feedback) OFF; 0,01 ... 8,00 °C (ranges with dec.point) OFF; 0,1...80,0 °C (ex works: 0,1)

Display "PROCESS"	Parameter	Adjustments or adjustment range „SET“
OPt	self tuning (autotune)	OFF self tuning out of action on self tuning on request (one time)

The tuning algorithm determines the characteristic values within the controlled process, and calculates the valid feedback parameters (P,D,I) and the cycle time ($C = 0.3 \times D$) of a PD/I-controller for a wide section of the range.

The self tuning activates during start-up shortly before the setpoint is reached. The setpoint must amount to the least 5% of the total range.
If activated after the setpoint has already been reached, the temperature will first drop by approx. 5% of the total range, in order to detect the exact amplification of the process.

Using the heat-cool controller, the temperature drop will be accelerated by switching on the cooling for a short duration.

The tuning algorithm can be activated at any time by selecting the **OPT=on** and pressing the „E“-key.

Zone display: During self tuning „OPt“ is shown in the display, alternating with the setpoint value.
Tendency display: „O“ is shown.

After having calculated the correct feedback parameters, the controller will lead the process value to the setpoint.

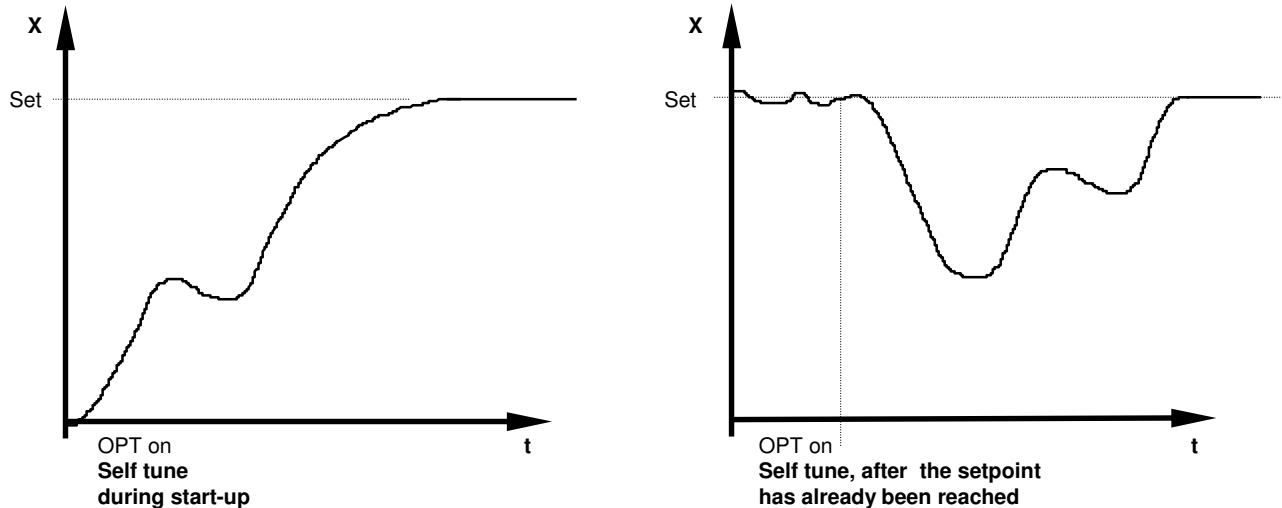

Self-tuning can be stopped by selecting the option **OPT = OFF** and pressing the „E“ - key.

OFSt	process value offset	-999 ... OFF ...1000 Units -99,9 ... OFF ... 100,0	(ex works: OFF)
This parameter serves to correct the input signal, e.g. for:			
- the correction of a gradient between the measuring point and the sensor tip,			
- the line resistance balancing of 2-line RTD (Pt100) sensors and			
- correction of the control deviation when using P- or PD-action.			
If for example the offset value is set to +5°C, then the real temperature measured by the sensor (when process is balanced) is 5°C less than the setpoint and the displayed process value.			

10. Operating Level, individual selectable for zones 1 and 2

Display "PROCESS"	Parameter	Adjustments or adjustment range „SET“
Process (process)	and	
	Setpoint 1 (set)	SP.Lo...SP.Hi (ex works: 0)

are displayed simultaneously (basic setting) in the selected zone.

SP2 Setpoint 2 OFF; SP.Lo SP.Hi (ex works: OFF)
 The 2. setpoint is active when the external contact K1 is closed.
 The corresponding LED „SP2“ lights up on the faceplate, and the second setpoint is shown in the setpoint-display.
 In order to change the value the parameter SP2 has to be selected.

SP1 rising ramp OFF; 0,1...100,0 °C/min. or °F/min. (ex works: OFF)
SP1 falling ramp OFF; 0,1...100,0 °C/min. or °F/min. (ex works: OFF)

A programmed ramp is always activated when the setpoint is altered or when the mains supply is switched on. The ramp constructs itself out of the momentary process value and the pre-selected setpoint. If the ramp is active, the corresponding LED lights up on the faceplate. The ramp can be activated for both setpoint1 and setpoint2. By programming the second setpoint accordingly a setpoint profile can be obtained (please see example below).

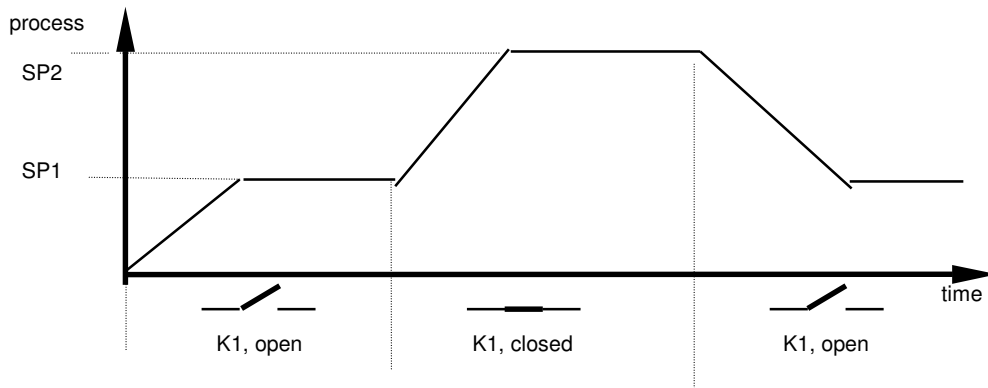

A1	Alarm value 1, switching point (switches relay A1)	Temperature monitoring: alarm value adjustment Signal contact, limit comparator, limit contact OFF; -199... 199 °C/°F OFF; -19,9... 19,9 °C/°F OFF; 0... 999 °C/°F (ex works: OFF)
A2	Alarm value 2, switching point (switches relay A2)	Temperature monitoring: Signal contact, limit comparator, limit contact OFF; -199... 199 °C/°F OFF; -19,9... 19,9 °C/°F OFF; 0... 999 °C/°F (ex works: OFF)

The range of adjustment is dependant of the sensor and the alarm configuration.
 Both have to be set in the configuration level.

11. Technical Data

Input RTD, Pt 100 (DIN):	2 - wire connection. Built-in protection against sensor breakage and short circuit. Sensor current: $\leq 0,5$ mA Calibration accuracy: $\leq 0,2$ % Linear error: $\leq 0,2$ % Influence of the ambient temperature: $\leq 0,01$ % / K
Input Thermocouple:	Built-in internal compensation point and protection against sensor breakage and incorrect polarity. Re-calibration not required for a line resistance of up to 50 Ohms. Calibration accuracy: $\leq 0,25$ % Linear error: $\leq 0,2$ % Influence of the ambient temperature: $\leq 0,01$ % / K
External, potential free contacts K1 – K5:	L = <3 VDC; H => 10 VDC; Ri > 22 KOhm
Outputs:	Bist. voltage signal, 0/18 V DC, max. 10 mA, short-circuit proof or Relay, max. 250 VAC, max. 3 A (cos-phi = 1)
Alarm outputs A1 and A2:	Relay, max. 250 VAC, max. 3 A (cos-phi = 1)
7-Segment-Display:	Process: 10 mm red, Set: 10 mm red
Data protection:	EAROM
CE - mark:	Tested according to 89 / 336 / EWG EN 50081-2, EN 50082-2 Electric safety: acc. to EN 61010
Power supply:	24 VDC, ± 25 %, max. 4W Same potential for: Sensors, bistable voltage output signals, contacts K1 - K5
Connections:	Screw terminals, Protection mode IP 20 (DIN 40050), Insulation class C
Permissible operating conditions:	Operating temperature: 0...50 °C / 32...122 °F Storage temperature: -30...70 °C / -22...158 °F Climate class: KWF DIN 40040; equivalent to annual average max. 75 % rel. humidity, no condensation
Casing:	Format: 96 x 96 mm (DIN 43700), installation depth 67mm Panel cutout: 92 +0,5 mm x 92 +0,5 mm Material: Noryl, self-extinguishing, non-drip, UL 94-V1 Protection mode: IP 20 (DIN 40050), IP 50 front side
Weight:	app. 300 g

Subject to technical improvements!

12. Error Displays

Display	Cause	Possible remedy
SP.Lo SP.Hi	Lower setpoint limit has been reached Upper setpoint limit has been reached	Reduce limit, if need be Increase limit, if need be
LOC	Parameter has been locked	Unlock, if need be
Er.Hi	Top range end has been exceeded, sensor defect	Check sensor and cable
Er.Lo	Bottom range end has been exceeded, sensor defect	Check sensor and cable
Er.OP	Self tuning error	Extinguish error signal by pressing the „E“-key. Check the self tuning conditions and restart.
Er.SY	System error	Extinguish error signal by pressing the „E“-key. Check all parameters. If the error signal continues please send the controller for examination.
Co.A1 Co.A2	Alarmconfiguration of alarm A1: OFF Alarmconfiguration of alarm A2: OFF	No alarm signal available No alarm signal available
-no- -PA-	Parameter not available in this zone.	
rEMo	Remote operation. Datatransmission via interface. Operation via keyboard not possible.	Set Parameter „rEMo“ to „OFF“

13. Installation Instructions

Make certain that the devices described here are used only for the intended purpose.

They are intended for installation in control panels.

The controller must be installed so that it is protected against impermissible humidity and severe contamination.

In addition, make sure that the permitted ambient temperature is not exceeded.

The electrical connections must be made according to the relevant locally applicable regulations.

If using a thermocouple sensor, the compensation cables must be laid directly to the controller terminals.

Transducers must be connected only in compliance with the programmed range.

Transducer cables and signal lines (e.g. logic or linear voltage outputs) must be laid physically separated from control lines and mains voltage supply cables (power cables) and must be shielded.

Spatial separation between controller and inductive loads is recommended.

Interference from contactor coils must be suppressed by connecting adapted RC-combinations parallel to the coils.

Control circuits (e.g. for contactors) should not be connected to the mains power supply terminals of the controller.

IMPORTANT: Before operation, the unit must be configured for its intended purpose under an experts guidance.

E.g. controller type, sensor type and range, alarm adjustment etc.. Please see: „Configuration Level“.

Disclaimer of liability

We have checked the contents of the document for conformity with the hardware and software described. Nevertheless, we are unable to preclude the possibility of deviations so that we are unable to assume warranty for full compliance. The information given in the publication is, however, reviewed regularly. Necessary amendments are incorporated in the following editions.

We would be pleased to receive any improvement proposals which you may have.

The information contained herein is subject to change without notice.

ELOTECH Industrieelektronik GmbH

Verbindungstr. 27

D - 40723 HILDEN, Germany

Tel.: 0049 2103 / 23055

Fax: 0049 2103 / 23057

www.elotech.de