



ELOTECH
INDUSTRIELELEKTRONIK GMBH

R 2200 - 836 ...
8 - Zones - „Heating-off-cooling“-Temperature-Controller

CANopen-, DeviceNet- or RS485- interface.

Heater-current monitoring (option).



B = 125mm
H = 105mm
D = 125mm

Contents

Contents	Page	2	
Type Code		2	
General		3	
System configuration: CANopen connection		4	
System configuration: DeviceNet connection		5	
Connection diagram: 8-zones controller R2200		6	
Operating levels, general		8	
Configuration level, parameter list		9	General settings
Heater current monitoring		11	
Parameter level, parameter list		12	Individual settings for each zone
Operating level, parameter list		18	Individual settings for each zone
Technical data		20	
Installation instructions		21	

**Please read this operating manual before starting up carefully.
Observe the installation and connecting instructions.**

Disclaimer of liability

We have checked the contents of the document for conformity with the hardware and software described. Nevertheless, we are unable to preclude the possibility of deviations so that we are unable to assume warranty for full compliance. The information given in the publication is, however, reviewed regularly. Necessary amendments are incorporated in the following editions. We would be pleased to receive any improvement proposals which you may have. This document may not be passed on nor duplicated, nor may its contents be used or disclosed unless expressly permitted. Violations of this clause will necessarily lead to compensation in damages. All rights reserved, in particular rights of granting of patents or registration of utility-model patents.

**Note: Only trained personnel following the safety regulations may commission the hereby described instruments.
It is essential, that one has well experience in installing a CANopen- or DeviceNet-device.**

Type code

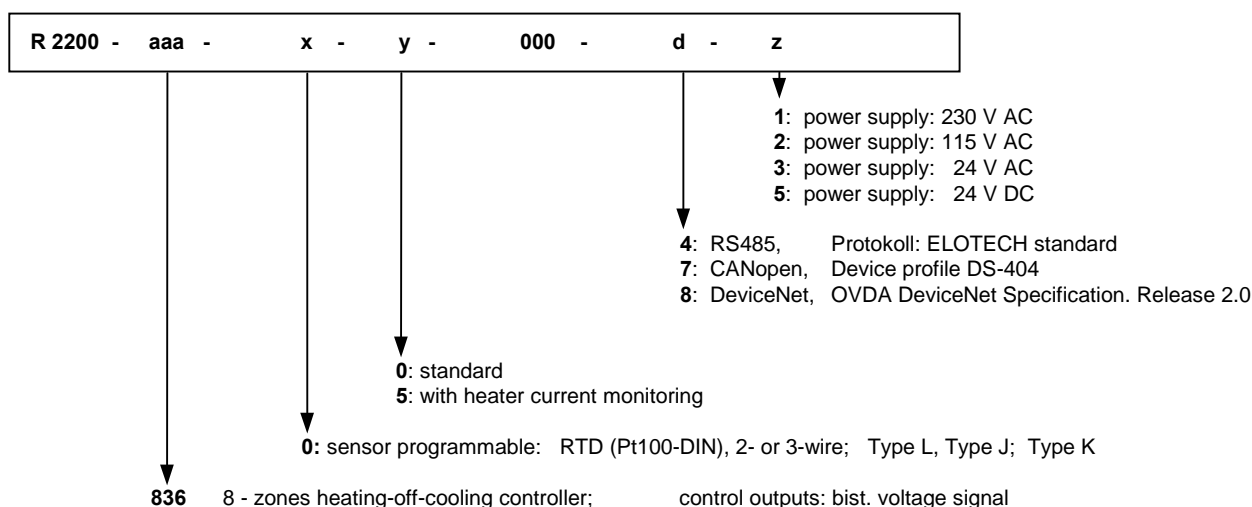

Controller unit, CANopen connection

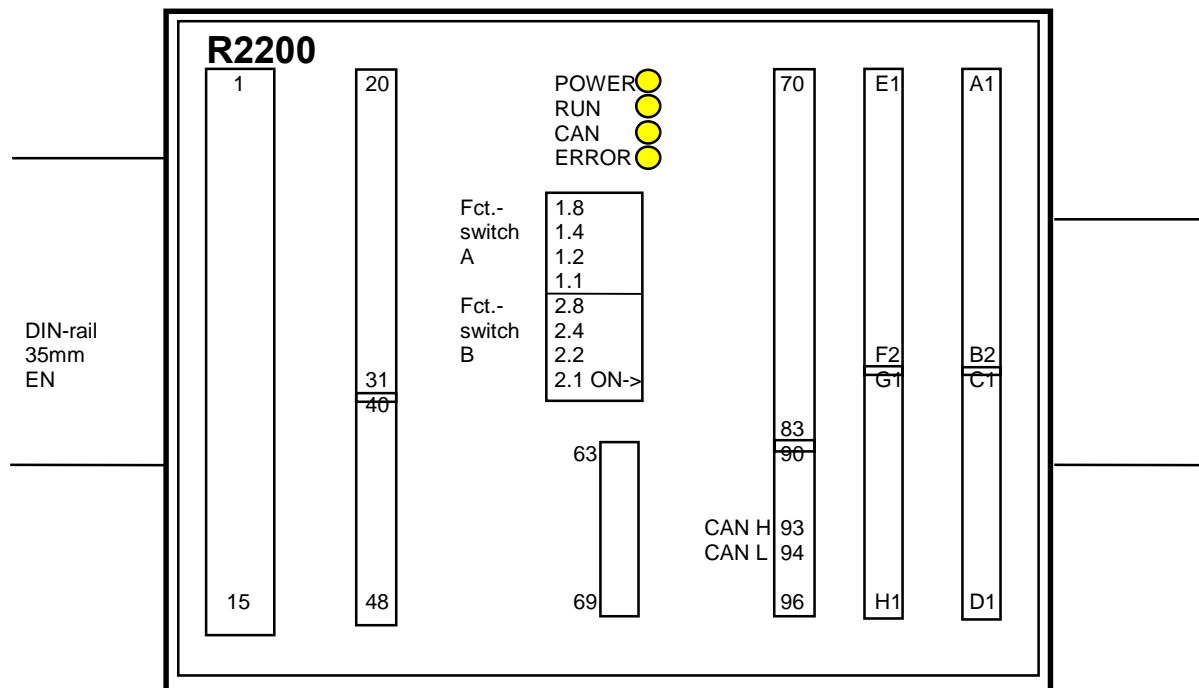

Controller connections: see next page

LED Power: Power on
 LED Run: CPU-clock, CPU = activ
 LED CAN: Interface-clock, interface = activ
 LED Error: flashes, if interface error detected (code:0)

Function - switch A:	1.8	no function				
	Baudrate:	1.4	1.2	1.1		
		off	off	off	10 kBaud	
		off	off	on	20 kBaud	
		off	on	off	50 kBaud	
		off	on	on	100 kBaud	
		on	off	off	125 kBaud	
		on	off	on	250 kBaud	
		on	on	off	500 kBaud	
		on	on	on	1000 kBaud	
Function - switch B:	Unit adress:	2.8	2.4	2.2	2.1	
		off	off	off	off	address: 1
		off	off	off	on	address: 2
		off	off	on	off	address: 3
		off	off	on	on	address: 4
		off	on	off	off	address: 5
		on	on	on	off	address: 15
		on	on	on	on	address: 16

CANopen – Spezifikation:	CANopen Master:	N
	CANopen slave:	Y
	Extended Boot-up:	N
	Minimum Boot-up:	Y
	COB ID Distribution:	Y (default, via SDO)
	Node ID Distribution:	N (via device keyboard)
	No of PDOs:	0RX, 1TX
	PDO Modes:	async
	Variable PDO mapping:	N
	Emergency Message:	Y
	Life guarding:	Y
	No. of SDOs:	1RX, 1TX
	Device Profile:	CiA DS-404

Controller unit, DeviceNet connection

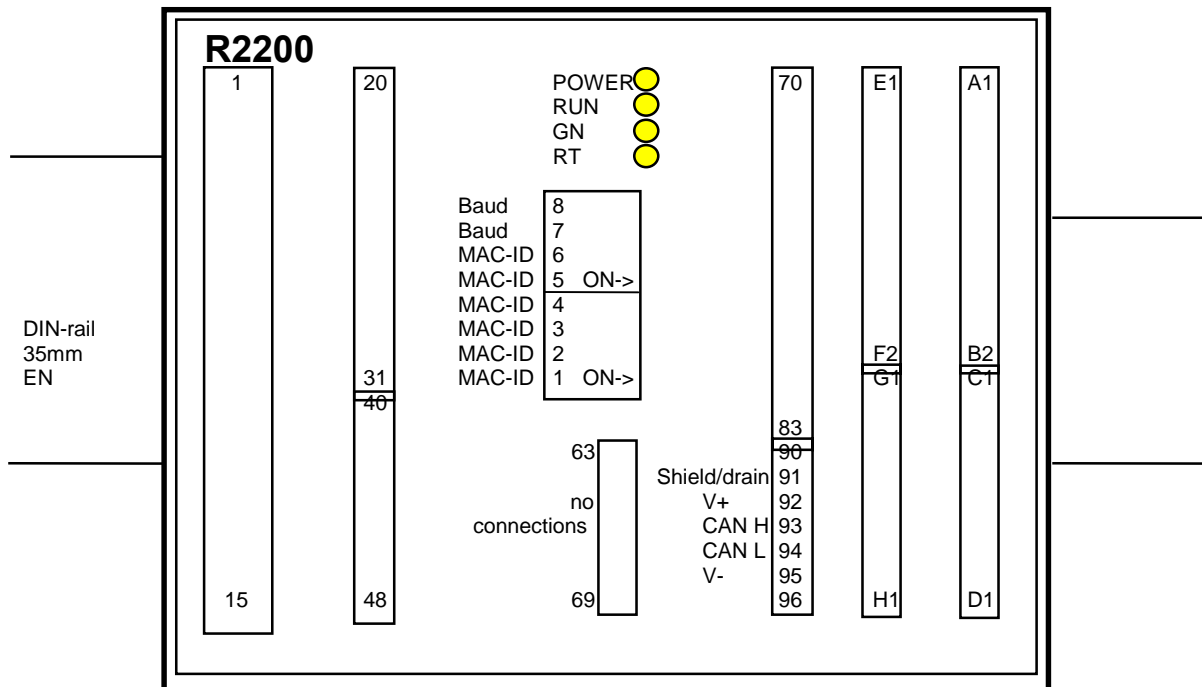

Controller connections: see next page

LED Power: Power on

LED Run: Clock, CPU = activ
On = system error

LED GN: Modul- and network LED

LED RT: Modul- and network LED

MAC-ID: DeviceNet- node number (Instrument adress)
1= 2^0 low bit. on = activ
6= 2^5 high bit. on = activ

Baud: Adjustment of the baud rate.

See separat DeviceNet-description.

Connection diagram

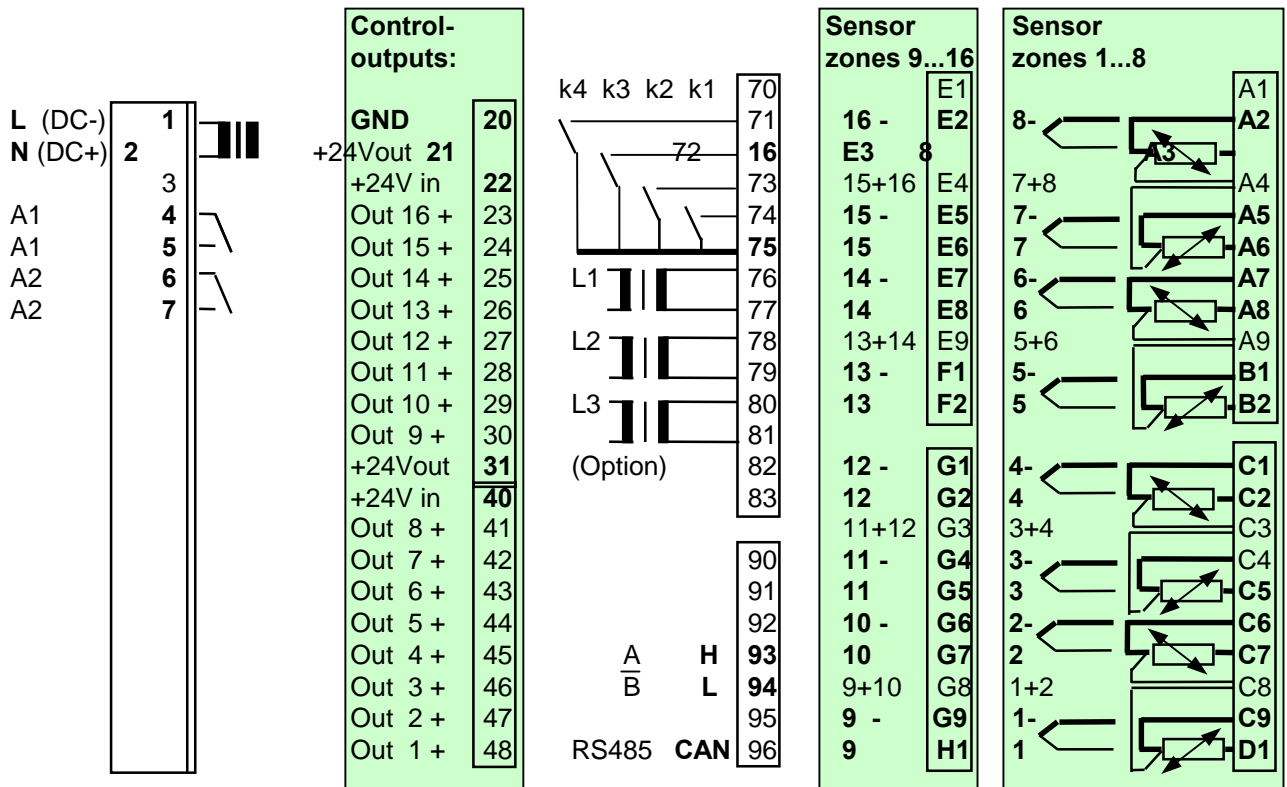

It is not permitted to connect the grounds of the sensor-inputs and bist. voltage-outputs with each other.

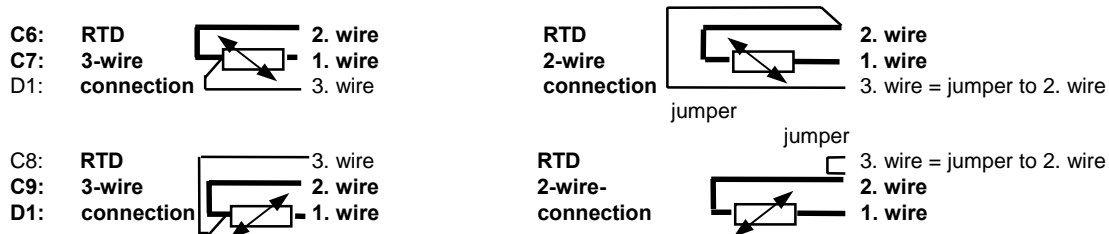

Control output OUT 1: Zone 1; 3-point-controller, output „heating“ to
Control output OUT 8: Zone 8; 3-point-controller, output „heating“
Control output OUT 9: Zone 1; 3-point-controller, output „cooling“ to
Control output OUT 16: Zone 8; 3-point-controller, output „cooling“

Alarm Output A1: Alarm 1 (Temperature alarm A1 for zones 1...8)
Alarm Output A2: Alarm 2 (Temperature alarm A2 for zones 1...8)

Setpoint Controlling: K1: open = Setpoint 1 (SP1) valid
 K1: closed = Setpoint 2 (SP2) valid, for all zones

CAN-Interface: K4: open = CAN: „operational“. Operation only with CANopen protocol.
 K4: closed = CAN: „operational“ always active.
 „k4“ must be closed, if the instrument is equipped with a CAN-interface but not used.

Heater current monitoring: 1 current – transformer / phase
 Single phase operation: terminals 76,77: L1
 Three-phase operation: terminals 76 – 81: L1, L2, L3

Connection diagram: controller outputs

1. With external voltage 24 VDC:

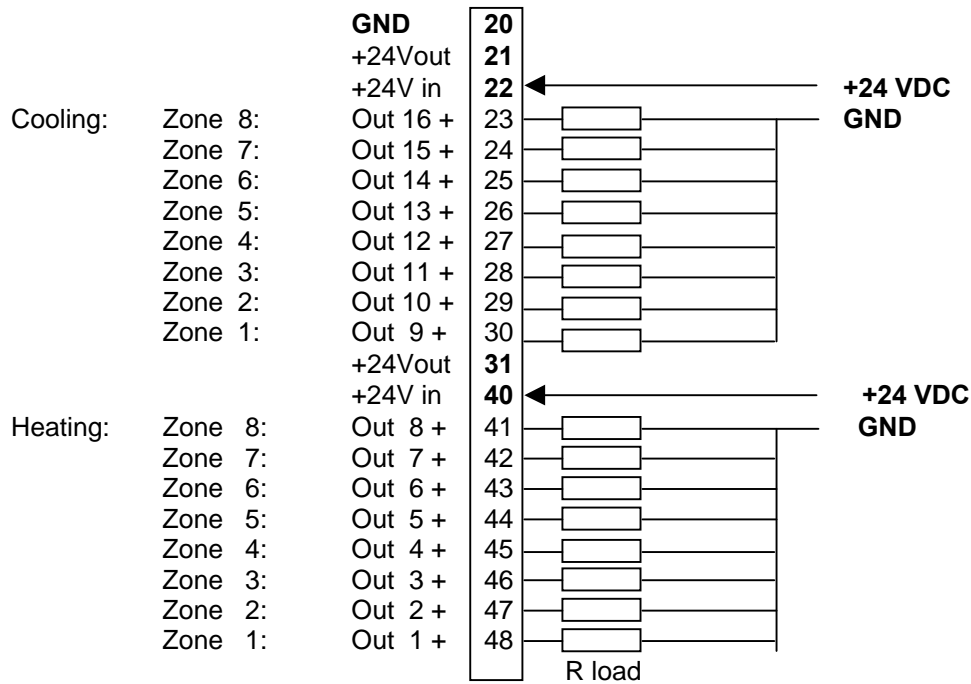

2. With internal voltage 24 VDC:

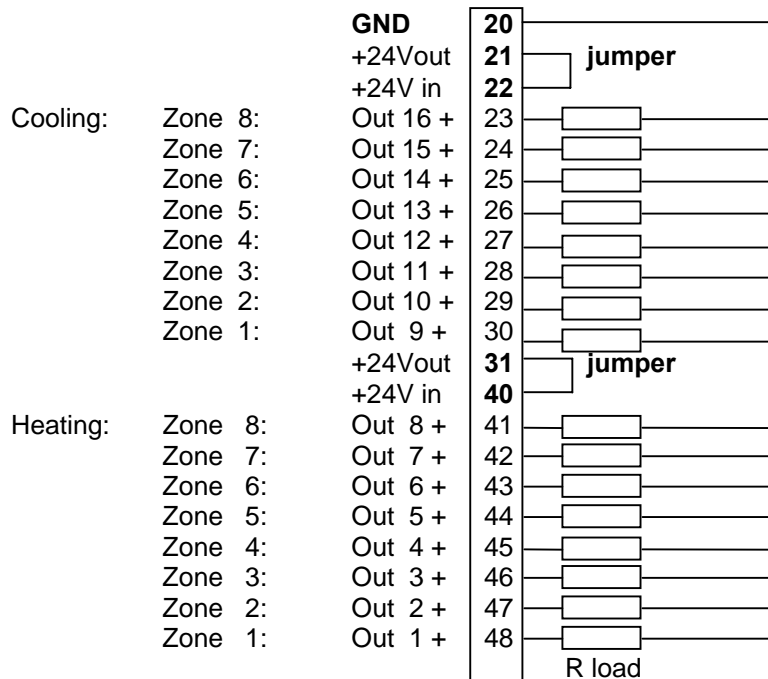

Operating Levels, general

Primary informations have to be made before taking the instrument into operation.

There are three different levels:

CONFIGURATION LEVEL:

This has to be programmed at first (device dependent parameters):

- Only TC- or RTD-connection for all zones? Or: Mixed connection ?
- Alarm configuration (valid for all zones)

This has to be programmed at second (zone dependent parameters):

- Controller type (for each zone)
- Input type (sensor type), sensor range (for each zone)
- Min. and max. setpoint range (for each zone)

PARAMETER LEVEL:

The controller (PID)- parameters have to be set here.

OPERATING LEVEL:

- Actual temperature value (read-only),
- Setpoint,
- Setpoint ramps,
- Alarm values,
- Heater current value (read-only).

Configuration level, Parameter list

Mnemonic	Parameter- description	CAN- Index / HEX	Parameter- value	Adjustment range
P - tc	Sensor mix (Pt100, RTD / Thermocouple-Mix)	2115	0	Zones 1- 16 : no Pt100 - only TC connection
			1	Zones 1- 2 : Pt100 - others : TC
			2	Zones 1- 4 : Pt100 - others : TC
			3	Zones 1- 6 : Pt100 - others : TC
			4	Zones 1- 8 : Pt100 - others : TC
			5	Zones 1- 10 : Pt100 - others : TC
			6	Zones 1- 12 : Pt100 - others : TC
			7	Zones 1- 14 : Pt100 - others : TC
			8	Zones 1- 16 : only Pt100 connection - no TC

ALARM MONITORING FUNCTION:

There are 2 alarm relays built in.

It is possible to configure this contacts either to monitor a temperature or to monitor the heater-current.

The selected configuration is effective for all control zones.

The individual temperature or heater current alarms A1 (or A2) of all zones are connected to the main, common contact A1 (or A2).

Please note:

In case of sensor error the alarms will react in the same way as range override. The alarm contacts therefore do not offer protection against all types of plant breakdown. With this in mind, we recommend the use of a second, independent monitor unit.

Care should be used to ensure, that the setpoints of the alarm contacts are programmed within the selected measuring range.

If a setpoint ramp has been programmed, the alarms that are relative to the setpoint (signal contact, limit comparator) are following the setpoint up the ramp.

Mnemonic	Parameter-description	CAN-Index / HEX	Parameter-value	Adjustment range
Co.A1	Alarm 1-Configuration (switches relay A1)	2508	0	alarm OFF, no alarm signalisation (ex works)
			1	signal contact, setpoint dependent: off-on
			2	limit contact, process value dependent: off-on
			3	limit comparator: off-on-off
			4	signal contact: on-off
			5	limit contact: on-off
			6	limit comparator: on-off-on
			7	limit comp. with start-up suppression: off-on-off
			8	heater current monitoring; limit contact: off-on
9	heater current monitoring; limit contact: on-off			
Co.A2	Alarm 2-Configuration (switches relay A2)	2518	0	alarm OFF, no alarm signalisation (ex works)
			1	signal contact, setpoint dependent: off-on
			2	limit contact, process value dependent: off-on
			3	limit comparator: off-on-off
			4	signal contact: on-off
			5	limit contact: on-off
			6	limit comparator: on-off-on
			7	limit comp. with start-up suppression: off-on-off
			8	heater current monitoring; limit contact: off-on
9	heater current monitoring; limit contact: on-off			
rE.A1	Relay A1 switching behaviour	2509	0 = dir	on: Relay A1 "activated" off: Relay A1 "not active"
			1 = inv	on: Relay A1 "not active" off: Relay A1 "activated"
rE.A2	Relay A2 switching behaviour	2519	0 = dir	on: Relay A2 "activated" off: Relay A2 "not active"
			1 = inv	on: Relay A2 "not active" off: Relay A2 "activated"

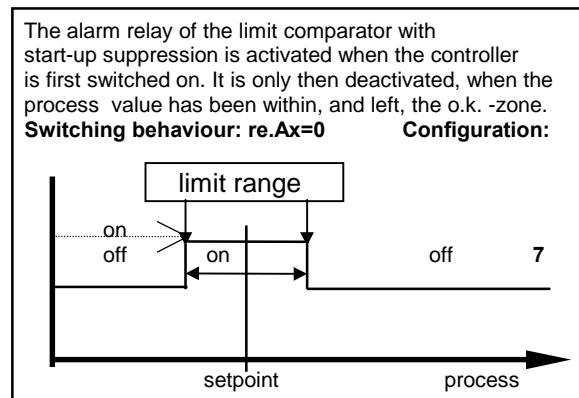
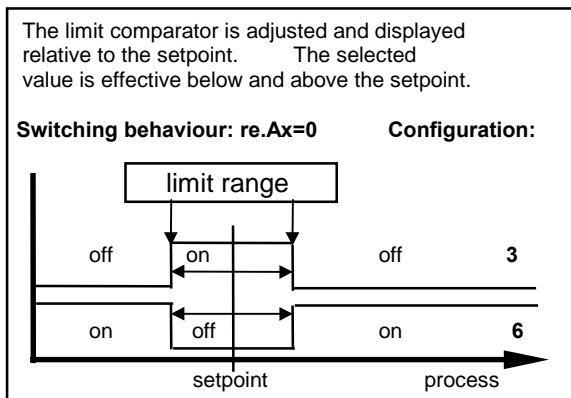
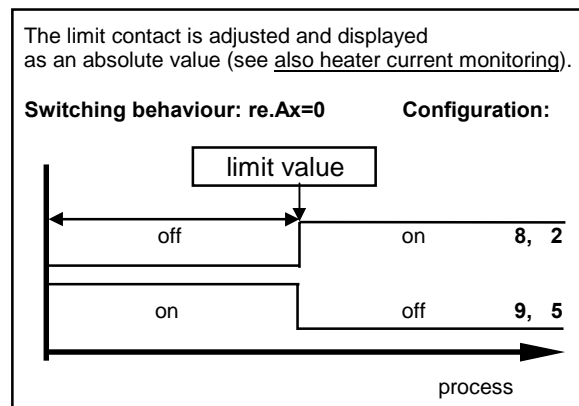
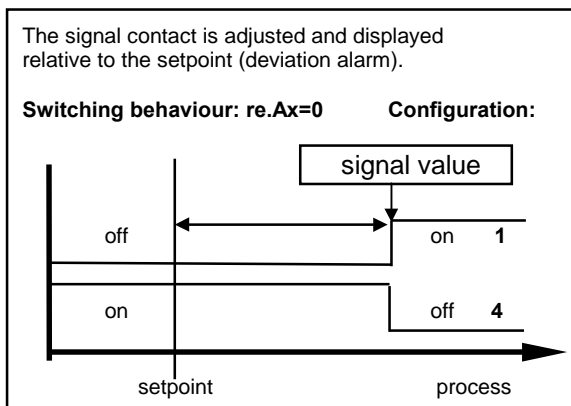

Heater current monitoring (option)

The following parameters are only relevant, if the heater current monitoring system is activated as described below:

Heater current monitoring via relay A1: Program parameter Co.A1 to number 8 or 9
 Heater current monitoring via relay A2: Program parameter Co.A2 to number 8 or 9

The heater current to be monitored, has to be programmed as an absolute value into the operating level for both relays A1 and A2.
 See Parameter: „A1“ or „A2“.

Please note:

If the supply voltage is low, the heater current has to be higher than the monitoring value. Otherwise the alarm signal will be activated.

If the heater current value falls below the monitoring value, an alarm signal (the relay switches) will be activated.

With the help of the parameter „dL.A1“ or „dL.A2“ it is possible to program a delay time.

If you do so, it is virtually impossible to get an unauthorized alarm signal.

When switching the power-on, the alarm signalisation will be suppressed until the heating current values for all zones has been scanned and verified.

The monitoring function and all possible adjustments are valid for all connected heating zones.

Mnemonic	Parameter-description	CAN-Index / HEX	Parameter-value	Adjustment range
dL.A1	delay time, relay A1 (monitoring via relay A1)	250A	0,1,2,3,4,5	5 steps adjustable (in sec.) 0 = no delay time The delay time depends of the current detection intervall time and the number of the active controller zones. It will be calculated as follows. $dL=ZnxCu.CYxS$ (S = 0,1,2,3,4 or 5)
dL.A2	delay time, relay A2 (monitoring via relay A2)	251A	0,1,2,3,4,5	5 steps adjustable (in sec.) 0 = no delay time The delay time depends of the current detection intervall time and the number of the active controller zones. It will be calculated as follows. $dL=ZnxCu.CYxS$ (S = 0,1,2,3,4 or 5)
Cu.CY	Current detection intervall	2403	1 ... 60 sec.	Time between the current measuring of two zones following each other.
C x.x	Min. leakage current value	2402	OFF; 0,0...99,9 A	Adjustment of the allowed min. leakage current value. In operation the min. leakage current value will be subtracted from the measured actual current value to calculate the real heater current value. If a permanent current is detected in one zone, the alarm relay will be activated. Please note: SSR's (especially if they are combined with RC-combinations) normally have small leakage currents. Heaters also have small leakage currents.
c	Leakage current	2401	0,0...99,9 A	Actual Leakage current (sum), if no SSR is switched on.

Parameter level, Parameter list

Individual selectable for zones 1 ... 16

Mnemonic	Parameter-description	CAN-Index / HEX	Parameter-value	Adjustment range			
ZonE	Zone on / off	6422	0	Controller zone: on	(ex works)		
			1	Controller zone: off			
ConF	Controller configuration	2423	0	2-point controller on-off: "heating"	(ex works)		
			1	2-point controller off-on: "cooling"			
			2	2-point controller off-on: "cooling", with non-linear cooling			
			3	3point-controller „heating-off-cooling“			
			4	3point-controller „heating-off-cooling“ with non-linear cooling *)			
			5	Zone actuates as an indicator only. No controller function.			
SEn	Sensor and measuring range selection	2110	0	Pt 100, 0,0... 99,9 °C	(ex works)		
			1	Pt 100, 32... 212 °F			
			2	Pt 100, -100... 200 °C			
			3	Pt 100, -148... 392 °F			
			4	Pt 100, 0... 400 °C			
			5	Pt 100, 32... 752 °F			
			6	Pt 100, 0... 800 °C			
			7	Pt 100, 32...1472 °F			
			or: if thermocouple connection is selected				
			0	T/C Fe-CuNi (L), 0... 400 °C			
			1	T/C Fe-CuNi (L), 32... 752 °F			
			2	T/C Fe-CuNi (L), 0... 800 °C			
			3	T/C Fe-CuNi (L), 32... 1472 °C			
			4	T/C Fe-CuNi (J), 0... 800 °C			
			5	T/C Fe-CuNi (J), 32... 1472 °C			
			6	T/C NiCr-Ni (K), 0... 1200 °C			
7	T/C NiCr-Ni (K), 32... 2192 °C						
8	T/C Pt10Rh-Pt (S), 0... 1600 °C						
9	T/C Pt10Rh-Pt (S), 32... 2912 °C						

If the Sensor selection is changed, the following parameters will be set as follows and need to be readjusted:

Setpoint 1, setpoint 2:	SP.Lo	Process value offset:	OFF
Lower setpoint limitation:	Bottom range end;	Higher setpoint limitation:	Top range end;
Setpoint-ramp values:	OFF;	Alarm values:	OFF;

Softstart-function

General function:

During the softstart the controllers' heating output response is limited to a pre-selected ratio, in order to achieve a slow baking out of high performance heat cartridges.

Simultaneously the output clock frequency is quadrupled. Once the process value reaches the softstart setpoint, it remains stable at this value for a pre-selected hold-duration time.

At the end of this period the process value rises to the valid setpoint.

This results in a slower, more regular heating period.

For this purpose the bistable voltage output must be taken, that actuates SSR relays.

If the softstart is active, the controllers' autotune function can't operated (Er.OP).

If a setpoint-ramp has been programmed, the softstart has priority, and the ramp will only become active after the softstart has been completed.

The softstart only works,

- if the parameter „1 P“ (prop. band, xp) is programmed > 0,1%.

- if the actual process value is lower than So.SP – 5% of the selected measuring range.

It is possible, to select this function for each zone separately.

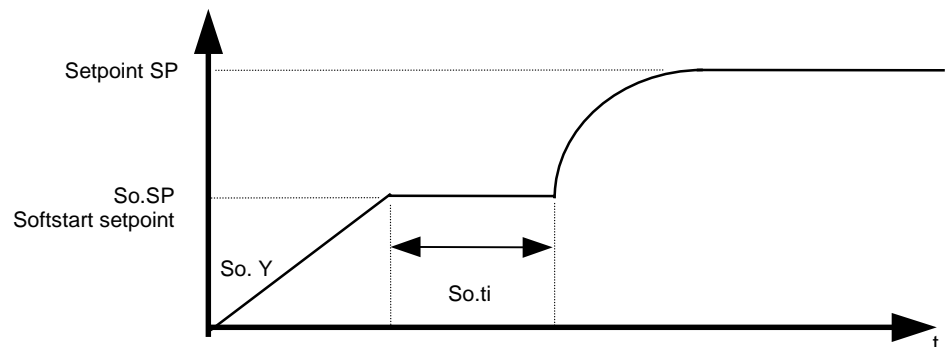

Mnemonic	Parameter-description	CAN-Index / HEX	Parameter-value	Adjustment range
So.St	Softstart-function	2700	0	Softstart not active (ex works) Next parameter So.Y, So.SP, So.ti are not shown.
			1	Softstart in action. The softstart function always runs, if the controller is switched on and / or if the actual temperature is below the softstart setpoint So.SP minus 5% of the range (e.g. range: 400°C -> 5%= 20°C).
So.Y	Softstart output ratio	2701	10 ... 100%	
So.SP	Softstart setpoint	2702	range: SP.Lo SP.Hi	
So.ti	Softstart duration time	2703	0 (=OFF); 0,1 ... 9,9 min.	

Mnemonic	Parameter- description	CAN- Index / HEX	Parameter- value	Adjustment range
----------	---------------------------	---------------------	---------------------	------------------

It is possible, to select this function for each zone separately.

Hand	Output ratio preselection	2421	0 = OFF 1 = Auto (Controller mode) 2 = Manual	(ex works)
------	------------------------------	------	---	------------

Setting: OFF Function not active

Setting: Auto

In event of sensor break the controller automatically maintains the last valid output ratio as the actuating signal.

This ratio can be manually altered in steps of 1%.

Under the following circumstances, the output ratio will be 0%:

- if the output ratio at time of the sensor break was
- if the controller is working along a setpoint-ramp.
- if the control deviation was more than 0,25% of the total range at the time of sensor break.
- if th prop. band (P; xp) = 0.
- if the soft start was active at the time of the sensor break.

A few seconds after the sensor break has been rectified, the controller returns to automatic operation and calculates the required output ratio.

An additional signal can be issued in the event of sensor break, if the alarm contacts are programmed accordingly.

Setting: Man

The controller now operates only as an actuator. Within the operation level, a manual output ratio (Index 7412) can be entered.

There is no further controlling action.

100%.

	Manual output ratio	7412	0...100%	
--	---------------------	------	----------	--

Mnemonic	Parameter-description	CAN-Index / HEX	Parameter-value	Adjustment range
Y	valid output ratio	6410		-100...100 % The output ratio shows the momentary calculated ratio. Read-only parameter. Output ratio for cooling is shown as a negative value.
1Y.Hi	output ratio limit heating	6414		0...100 % (ex works: 100) Limitation of the output ratio is only necessary when: the heating or cooling energy supply is grossly over-dimensioned compared to the power required, or to turn off a control output (setting = 0%). Under normal circumstances no limitation is needed (setting = 0%). The limitation becomes effective, when the controllers' calculated output ratio is greater than the maximum permissible (limited) ratio. Warning! The output ratio limitation does not work during autotune.
1 P	Xp, prop.-band (P) heating	7450		OFF; 0,1...100,0 % (ex works: 3,0) If „ 1 P “ = OFF (control action: on-off, without feedback) next parameter: „ 1 sd “.
1 I	Tn, reset (I) heating	7452		OFF; 1...1000 secs (ex works: 150)
1 d	Tv, rate (D) heating	7454		OFF; 1...200 secs (ex works: 30)
				Normally the controller works using PD/I control action. This means, controlling without deviation and with practically no overshoot during start-up. The control action can be altered in its structure by making the following adjustments to the parameters: a. no control action, on-off (setting P = OFF) b. P-action (setting D and I = 0) c. PD-action (setting I = 0) d. PI-action (setting D = 0) e. PD/I modified PID-action
1 C	cycle time heating	7456		0,5...240,0 secs (ex works: 10,0) The switching frequency of the actuator can be determined by adjusting the cycle time. This is the total time needed for the controller to switch on and off once. Bistable voltage outputs: cycle time 0,5...10 secs
1 Sd	control sensivity heating	2600		Only if: 1 P = Xp = OFF (On-off action, without feedback) OFF; 0,1...80,0 °C (ex works: 0,1)

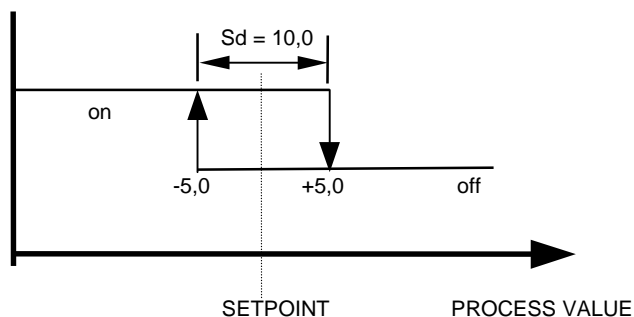

The following parameters apply **only** to types **R 2200 - x3x**
and if configured as heat-off-cool controllers (**configuration: „3 P“ or „3Pnc“**):

Sh	switch-point difference	7440	<p>OFF; 0,1...80,0 °C/°F (ex works: OFF) OFF; 0,01...8,00 °C/°F</p> <p>This parameter raises the setpoint (switch-point) for cooling output by the displayed value. It can be help to reduce the switching frequency between the heating and cooling outputs, if this is to high. Simultaneously activation of heat and cool outputs is not possible.</p>
2Y.Hi	output ratio limit cooling	6413	<p>0...100 % (ex works: 100)</p> <p>Limitation of the output ratio is only necessary when: the heating or cooling energy supply is grossly over-dimensioned compared to the power required, or to turn off a control output (setting = 0%). Under normal circumstances no limitation is needed (setting = 0%). The limitation becomes effective, when the controllers' calculated output ratio is greater than the maximum permissible (limited) ratio. Warning! The output ratio limitation does not work during autotune.</p>
2 P	Xp, prop.-band (P) cooling	7451	<p>OFF; 0,1...100,0 % (ex works: 3,0)</p> <p>If „ 1 P “ = OFF (control action: on-off, without feedback) next parameter: „ 1 sd “.</p>
2 I	Tn, reset (I) cooling	7453	<p>OFF; 1...1000 secs (ex works: 150)</p>
2 d	Tv, rate (D) cooling	7455	<p>OFF; 1...200 secs (ex works: 30)</p> <p>Normally the controller works using PD/I control action. This means, controlling without deviation and with practically no overshoot during start-up. The control action can be altered in its structure by making the following adjustments to the parameters:</p> <ol style="list-style-type: none"> no control action, on-off (setting P = OFF) P-action (setting D and I = 0) PD-action (setting I = 0) PI-action (setting D = 0) PD/I modified PID-action
2 C	cycle time cooling	7457	<p>0,5...240,0 secs (ex works: 10,0)</p> <p>The switching frequency of the actuator can be determined by adjusting the cycle time. This is the total time needed for the controller to switch on and off once. Bistable voltage outputs: cycle time 0,5...10 secs</p>
2 Sd	control sensivity cooling	2601	<p>Only if: 1 P = Xp = OFF (On-off action, without feedback) OFF; 0,1...80,0 °C (ex works: 0,1)</p>

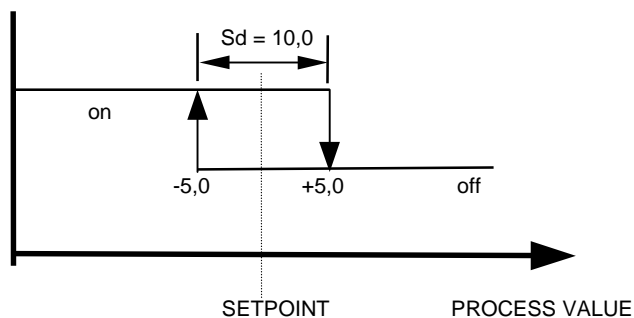

Mnemonic	Parameter-description	CAN-Index / HEX	Parameter-value	Adjustment range
OPT	self tuning (autotune)	6424	0 1	OFF on self tuning out of action self tuning active (one time)

The tuning algorithm determines the characteristic values within the controlled process, and calculates the valid feedback parameters (P,D,I) and the cycle time ($C = 0.3 \times D$) of a PD/I-controller for a wide section of the range.

The self tuning activates during start-up shortly before the setpoint is reached. The setpoint must amount to the least 5% of the total range.
If activated after the setpoint has already been reached, the temperature will first drop by approx. 5% of the total range, in order to detect the exact amplification of the process.

The tuning algorithm can be activated at any time.

After having calculated the correct feedback parameters, the controller will lead the process value to the setpoint.

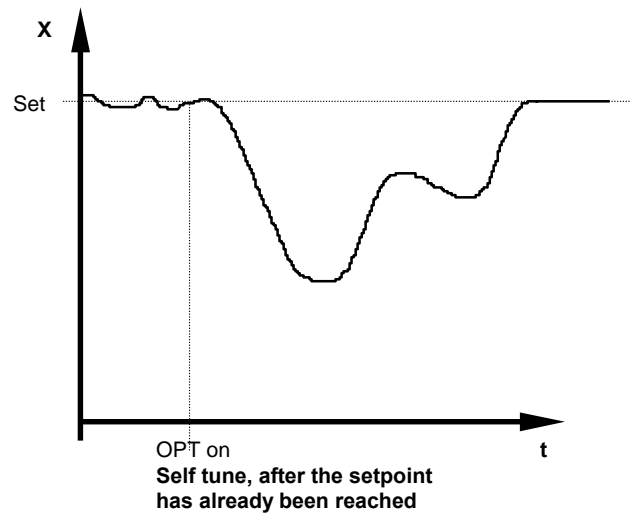
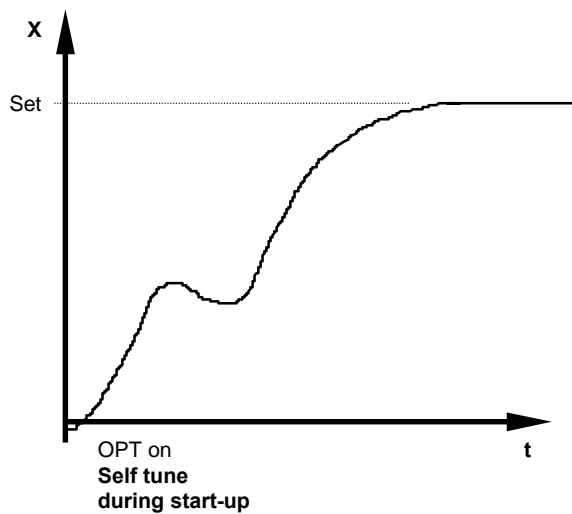

Operating level, Parameter list

(individual selectable for zones 1 ... 16)

Mnemonic	Parameter- description	CAN- Index / HEX	Parameter- value	Adjustment range
°C/°F	Process temperature actual value	7400		Read-only parameter
OFSt	process value offset	7124	-99 ... OFF ... 100 Units -9,9 ... OFF ... 10,0	(ex works: OFF=0) This parameter serves to correct the input signal, e.g. for: - the correction of a gradient between the measuring point and the sensor tip, - the line resistance balancing of 2-line RTD (Pt100) sensors - correction of the control deviation when using P- or PD-action. If for example the offset value is set to +5°C, then the real temperature measured by the sensor (when process is balanced) is 5°C less than the setpoint and the monitored process value.
SPact.	Setpoint, actual	7401		Read-only parameter
SP1	Setpoint 1 (main setpoint)	7402	SP.Lo...SP.Hi	(ex works: 0)
SP2	Setpoint 2	7403	OFF; SP.Lo SP.Hi	(ex works: OFF=0) The 2. setpoint is active when the external contact K1 is closed. In order to change the value the parameter SP2 has to be se- lected. SP2=OFF: SP1 is still valid, if the contact K1 is closed.
SPH	Higher setpoint limitation	7405	SP.Lo ... top end of measuring range	
SPL	Lower setpoint limitation	7404	SP.Ho ... bottom end of measuring range	
SP ↑	rising ramp	2408	OFF; 0,1...100,0 °C/min. or °F/min.	(ex works: OFF=0)
SP ↓	falling ramp	2409	OFF; 0,1...100,0 °C/min. or °F/min. A programmed ramp is always activated when the setpoint is altered or when the mains supply is switched on. The ramp constructs itself out of the momentary process value and the pre-selected setpoint. The ramp can be activated for both setpoint1 and setpoint2. By programming the second setpoint accordingly a setpoint profile can be obtained (please see example below).	(ex works: OFF=0)

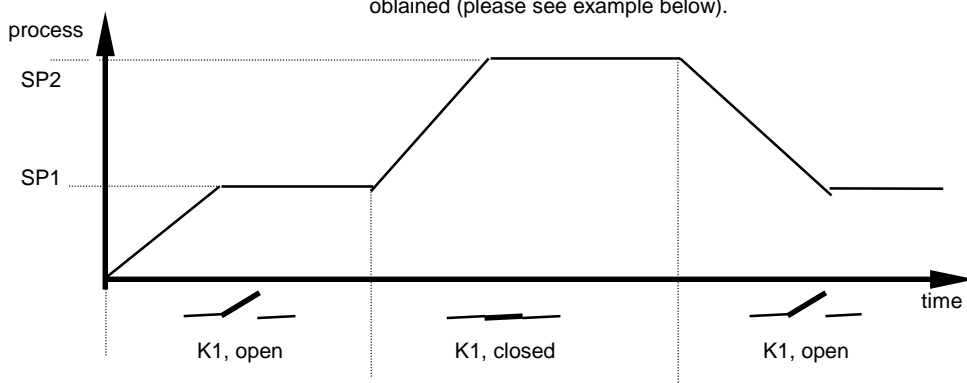

Mnemonic	Parameter- description	CAN- Index / HEX	Parameter- value	Adjustment range
A1	Alarm value 1, switching point (switches relay A1)	750A		<p>Temperature monitoring: alarm value adjustment Signal contact, limit comparator, limit contact OFF; -999... 1000 °C/°F (ex works: OFF=0) OFF; -99,9... 100,0 °C/°F OFF; 0... 1000 °C/°F or Heater current monitoring: alarm value adjustment Limit contact OFF: 0,0 ...99,9 A (ex works: OFF=0)</p>

A2	Alarm value 2, switching point (switches relay A2)	751A		<p>Temperature monitoring: alarm value adjustment Signal contact, limit comparator, limit contact OFF; -999... 1000 °C/°F (ex works: OFF=0) OFF; -99,9... 100,0 °C/°F OFF; 0... 1000 °C/°F or Heater current monitoring: alarm value adjustment Limit contact OFF: 0,0 ...99,9 A (ex works: OFF=0)</p>
-----------	--	-------------	--	--

The range of adjustment is dependant on the sensor, the connected current transformers and the alarm configuration.
Both have to be set in the configuration level.

Cur	Heater current, actual value	2400	0,0...99,9 A	Read-only parameter Indication of the actual heater current.
------------	---	-------------	--------------	---

Technical Data

Input RTD, Pt 100 (DIN):	2 - or 3 - wire connection possible. Built-in protection against sensor breakage and short circuit. Max. permissible line resistance by 3-wire connection: 80 Ohms Sensor current: ≤ 1 mA Calibration accuracy: $\leq 0,2$ % Linear error: $\leq 0,2$ % Influence of the ambient temperature: $\leq 0,01$ % / K
Input Thermocouple:	Built-in internal compensation point and protection against sensor breakage and incorrect polarity. Re-calibration not required for a line resistance of up to 50 Ohms. Calibration accuracy: $\leq 0,25$ %
Setpoint selection:	Ext. potential-free contact, switching voltage appr. 24 V DC, max. 1 mA. Selection between SP1 and SP2 valid for all zones.
Control outputs OUT 1 ... OUT 8:	Bist. voltage signal, 0/18 V dc, max. 10 mA, short-circuit proof or
Alarm outputs A1 and A2:	Relay, max. 250 VAC, max. 3 A (cos-phi = 1)
Ser. Interface:	CANopen Device profile DS-404 or DeviceNet protocol or RS485 with ELOTECH-standard protocol
Data protection:	EAROM
CE - Mark:	Tested according to 89 / 336 / EWG EN 50081-2, EN 50082-2
Power supply:	- 230 V AC, ± 10 %, 48...62 Hz. Appr. 7VA. - 24 V DC, +/-20%. Appr. 7W
Connections:	Screw terminals, Protection mode IP 20 (DIN 40050), Insulation class C
Permissible operating conditions:	Operating temperature: 0...50 °C / 32...122 °F Storage temperature: -30...70 °C / -22...158 °F Climate class: KWF DIN 40040; equivalent to annual average max. 75 % rel. humidity, no condensation
Casing; Controller unit:	Fabr. Phoenix: CE; B=125mm, H= 105mm, D=125mm For DIN-rail mounting (35mm symmetric, EN 50 022) Material: Polycarbonat (PC); Protection: IP 20 (DIN 40050)
Heater current monitoring:	
Current transformer 1:1000: (Type M2000)	Passive through current transformer with snap-in attachment for DIN rail mounting (EN 50022, 35mm). Connections to the controller: 2 x 6,3mm flat connectors.
Heater current detection and indication range:	0...max. 60,0A. Single-phase operation. 0...max. 99,9 A. Three-phase operation. The sum of the current of all three phases of one controller zone will be monitored. Variations of the power supply voltage have to be considered when the the alarm values are programmed.
Current detection interval time programmable (1...60 sec.).	This is the time between the measuring of two successive controller zones.
Alarm delay time programmable.	It depends upon the current detection interval time and the number of the connected temperature zones (min. 8 sec.).
Subject to technical improvements!	

Installation Instructions

Make certain that the devices described here are used only for the intended purpose. They are intended for installation in control panels. The instrument must be installed so, that it is protected against impermissible humidity and severe contamination. In addition, make sure that the permitted ambient temperature is not exceeded.

The electrical connections must be made according to the relevant locally applicable regulations.

If using a thermocouple sensor, the compensation cables must be laid directly to the controller terminals. Transducers must be connected only in compliance with the programmed range.

Transducer cables and signal lines (e.g. logic or linear voltage outputs) must be laid physically separated from control lines and mains voltage supply cables (power cables). To be in compliance with the CE-regulations, for sensor signals lines it is necessary to use shielded wires. Spatial separation between controller and inductive loads is recommended. Interference from contactor coils must be suppressed by connecting adapted RC-combinations parallel to the coils. Control circuits (e.g. for contactors) should not be connected to the mains power supply terminals of the controller.

IMPORTANT:

Before operation, the unit must be configured for its intended purpose
(e.g. controller type, sensor type and range, alarm adjustment etc.)

ELOTECH Industrieelektronik GmbH

Verbindungstr. 27

D - 40723 HILDEN, Germany

Tel.: 0049 2103 / 23055

www.elotech.de

Fax: 0049 2103 / 23057

elotech@t-online.de