



Format: 22,5mm x 75,0mm x 105mm

SGmC

Microcontroller-Based Limit Value Alarm

DESCRIPTION AND OPERATING MANUAL

Contents

1. Contents.....	2
2. Installation instructions.....	2
3. Type Code	3
4. Connection diagram.....	3
5. Technical Data.....	4
6. Display and keyboard.....	5
7. Configuration.....	5
8. Instruction.....	7
9. Status- and Errordisplay	8

Please read this operating manual before starting up carefully.

Observe the installation and connecting instructions.

Disclaimer of liability

We have checked the contents of the document for conformity with the hardware and software described. Nevertheless, we are unable to preclude the possibility of deviations so that we are unable to assume warranty for full compliance. The information given in the publication is, however, reviewed regularly. Necessary amendments are incorporated in the following editions. We would be pleased to receive any improvement proposals which you may have.

The information contained herein is subject to change without notice.

1. Installation instructions

Make certain that the devices described here are used only for the intended purpose. They are designed for installation with DIN-rail EN 50022 mounting.

The device must be installed so that it is protected against impermissible humidity and severe contamination.

A distance from 5mm to the neighbouring devices must be kept.

In addition, make sure that the permitted ambient temperature is not exceeded.

The electrical connections must be made according to the relevant german VDE directives and locally applicable regulations.

Transducer cables and signal lines (e. g. logic output lines) must be laid physically separated from control lines and mains voltage supply cables (power cables).

If using a thermocouple sensor, the compensation cables should be laid directly to the controller terminals.

Physical separation between the device and inductive loads is recommended.

Interference from contactor coils must be suppressed by connecting adapted RC-combinations parallel to the coils. Control circuits (e.g. for contactors) should not be connected to the power supply terminals of the device.

Important

Before operation, the unit must be configured for its intended purpose (e.g. sensor type, alarm adjustment etc.).

2. Type Code

SGmC - 10 - 00 - 1
 ↓
 1
 2
 5

Power supply: AC 230 V (internal jumper AC 115 V)
 Power supply: AC 115 V
 Power supply: DC 24 V

3. Connection diagram

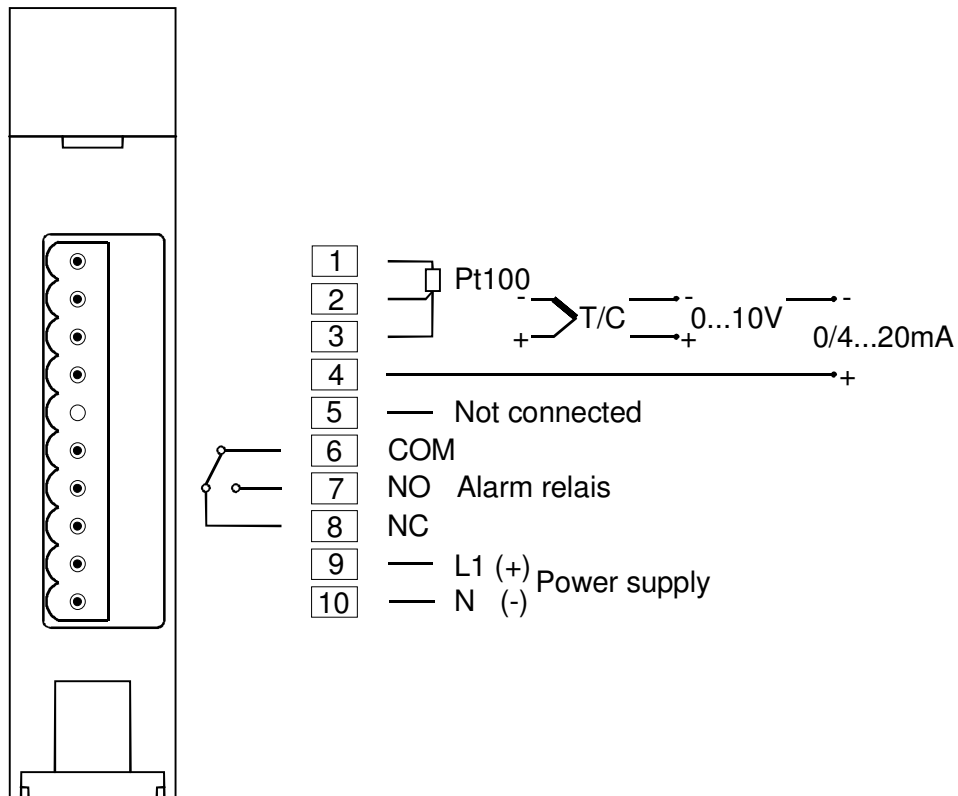

The SGmC will be connected to using the screw terminal on the bottom of the cases.
 Please find enclosed the suitable plug-in terminal strip.

Switching behaviour of the alarm relay

In case of an alarm the relay will open, in normal operation it is closed.

The relais is a changeover relay, so that you can change this normal behaviour.

In case of power supply breakdown the relay has the same behaviour as in case of an alarm.

Device Installation

The instrument is constructed with plug-in technology. The instrument can be drawn out of the housing together with the front panel. This, however, can only be done once the instrument has been isolated from its power supply.

4. Technical Data

Inputs:

- **TC:** Built-in internal compensation point and protection against sensor breakage and incorrect polarity.
Re-Calibration not required for a line resistance up to 50 Ohm.
Calibration accuracy: $\leq 0,25 \%$

- **Pt 100 (RTD):** 2- or 3- wire connection possible.
Built-in protection against sensor breakage and short-circuit.
Maximum permissible line resistance by 3-wire connection: 80 Ohm
Sensor current: $\leq 0,15 \text{ mA}$
Calibration accuracy: $\leq 0,2 \%$

- **Standard signals:** 0/4...20mA, ($R_i < 10 \text{ Ohm}$)
DC 0...10V, ($R_i > 100 \text{ k-Ohm}$)
Calibration accuracy: $\leq 0.2\%$

Linear error: $\leq 0,2\%$
Influence of the ambient temperature: $\leq 0,01\%/K$

Alarm output: Relay, (changeover) max. AC 250 V, 3 A at $\cos\text{-}\phi = 1$

EMC: Tested according to EU-directives 89/336
- emission according to EN 61000-6-4
- interference resistance according to EN 61000-6-2

Power Supply: AC 230 V / AC 115V, $\pm 10 \%$, 48...62 Hz,
(configurable via 2 internal bridges):
AC 230 V: bridge in position A - B (adjustment ex works)
AC 115 V: bridge in position B - C
Option: DC 24 V, $\pm 20 \%$, permissible residual ripple max 5 %

Connections: screw terminals, protection IP 20 (DIN 40050), insulation class C

Permissible operating conditions:

Operating temperature: 0 to 50°C / 32 to 122°F
Storage temperature: -30 to 70°C / -22 to 158°F
Climate class: KWF DIN 40040;
Equivalent to annual average max. 75% relative humidity.
No condensation.

Casing: Format: 22,5mm x 75mm x 105 mm
Material: ABS, self-extinguishing, non-drip, UL 94-HB to V0
Protection mode: IP 20 (DIN 40050)

Weight: approx. 135 g

Subject to technical improvements!

5. Display and keyboard

The SGmC will be configured and used by 8 DIP-switches, 3 rotary switches and 1 button.

The DIP-switches placed in the casing are used to configure the SGmC. You configure the sensor, the temperature range and the alarm behaviour of the SGmC.

The 3 rotary switches and the button are on the front. The 3 rotary switches adjust the limit value and the button resets the self-hold function of the SGmC.

For showing the conditions the SGmC has two LEDs. The green LED displays that the controller is on and the red LED is to display an alarm.

Please notice: For the Pt100 (RTD) with a measuring range of $-99\dots+99^{\circ}\text{C}$ you have to adjust the +/- range by the first upper rotary switch as follows:

+ = 0
- = 1

6. Configuration

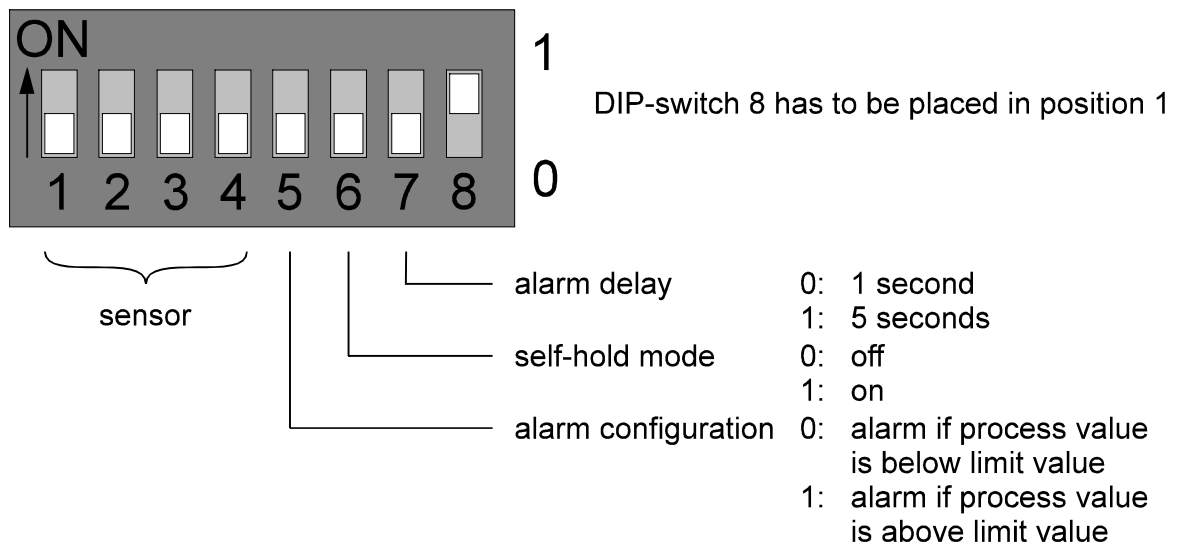

Parameter	Input-configuration	DIP-switches placing (DIP-switches)
Sensor	Pt100 (RTD) -200 ... 0 °C	0 0 0 0
(1,2,3,4)	Pt100 (RTD) 0 ... 400 °C	0 0 0 1
	Pt100 (RTD) 0 ... 800 °C	0 0 1 0
	Fe-CuNi (L) 0 ... 800 °C	0 0 1 1
	Fe-CuNi (J) 0 ... 800 °C	0 1 0 0
	Cu-CuNi (T) 0 ... 400 °C	0 1 0 1
	NiCr-Ni (K) 0 ... 1370 °C	0 1 1 0
	NiCr-CuNi (E) 0 ... 700 °C	0 1 1 1
	PtRh10-Pt (S) 0 ... 1760 °C	1 0 0 0
	PtRh13-Pt (R) 0 ... 1760 °C	1 0 0 1
	Pt100 (RTD) -99 ... +99 °C	1 0 1 0
	NiCrSi-NiSi (N) 0 ... 1300 °C	1 0 1 1
	Current 0 ... 20 mA	1 1 0 1
	Current 4 ... 20 mA	1 1 1 0
	Voltage 0 ... 10 V	1 1 1 1

Configuration

Parameter (DIP-switch)	range of adjustment	DIP switch adjustment
---------------------------	---------------------	-----------------------

Alarm configuration	Crossing alarm value to lower : Alarm on	0
(5)	Crossing over alarm value : Alarm on	1

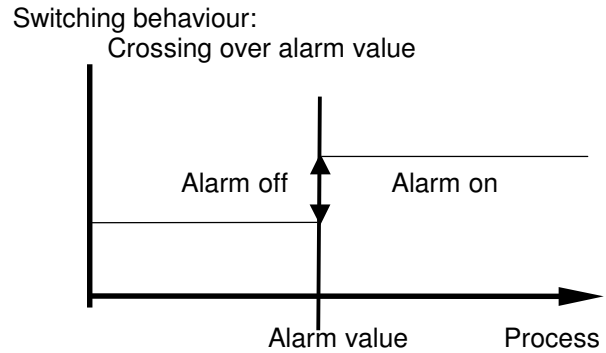
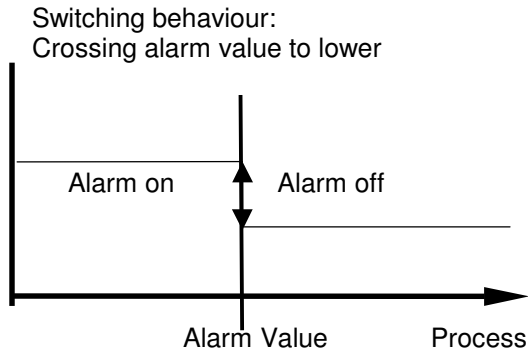

Self hold mode	off	0
(6)	on	1

The red alarm LED flashes on active self hold.
To reset the self hold push the reset button or break the power supply.

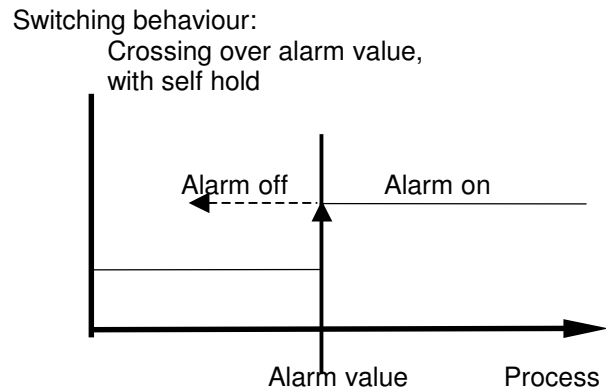
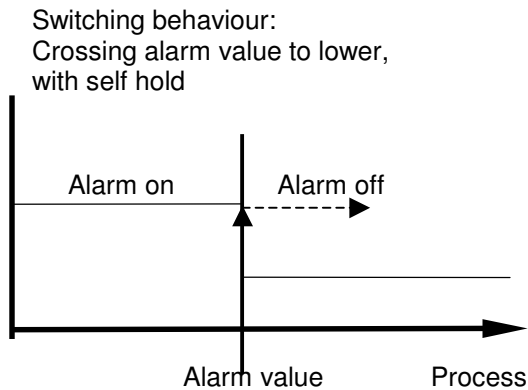

Alarm delay	1 second	0
(7)	5 seconds	1

The alarm will be switched on in a delay time.
The switch off won't be delayed.

7. Instruction

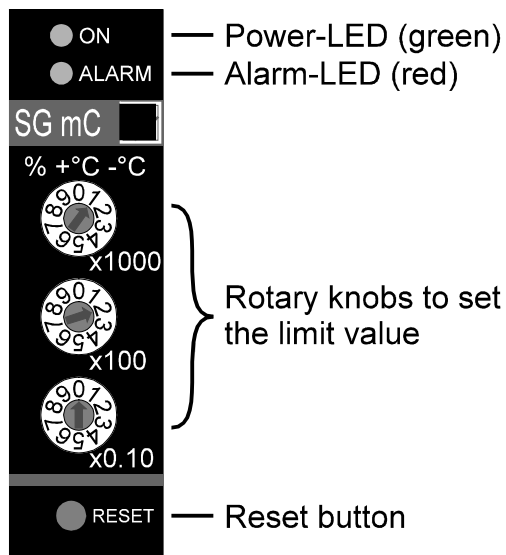

Alarm value setting:

The value is set with the rotary knobs in front of the SGmC.

In dependence of the sensor and the measuring range, the sign, the value and the unit will vary.

Sensor	Measuring range	unit/ sign		Value of rotary knobs		
				top	centre	bottom
Pt100 (RTD)	-99 ... +99	°C	-°C	+/-	10	1
Pt100 (RTD)	-200 ... 0	°C	-°C	100	10	1
Pt100 (RTD)	0 ... 400	°C	+°C	100	10	1
Pt100 (RTD)	0 ... 800	°C	+°C	100	10	1
Fe-CuNi (L)	0 ... 800	°C	+°C	100	10	1
Fe-CuNi (J)	0 ... 800	°C	+°C	100	10	1
Cu-CuNi (T)	0 ... 400	°C	+°C	100	10	1
NiCr-Ni (K)	0 ... 1370	°C	+°C	1000	100	10
NiCr-CuNi (E)	0 ... 700	°C	+°C	100	10	1
PtRh10-Pt (S)	0 ... 1760	°C	+°C	1000	100	10
PtRh13-Pt (R)	0 ... 1760	°C	+°C	1000	100	10
NiCrSi-NiSi (N)	0 ... 1300	°C	+°C	1000	100	10
Current	0 ... 20	mA	%	10	1	0.1
Current	4 ... 20	mA	%	10	1	0.1
Voltage	0 ... 10	V	%	10	1	0.1

To adapt the sensor and the measuring range, color the digits and letters with a black waterproofed felt pen.

Example:

Pt100 sensor, -200 to 0 °C: Color the units % and +°C, so that only -°C is visible.

At the rotary knobs reduce the top label to 100, the centre label to 10 and the bottom label to 1.

Reset of self hold:

Pushing the reset button will reset the self hold.

Another choice is to break the power supply.

8. Status- and Errordisplay

Normaly operation

If the power LED lights green, the SGmC is in normaly operation. There is no operating error or sensor break.

The alarm LED displays an active alarm. If the alarm LED flashes, the SGmC is in self hold.

Error operation

The power LED flashes, the alarm LED lights up and the relais drop off.

Sensor- or operating error:

- bottom range or top range has been exceeded (i.e. short circuit or line break of the sensor).
- The measuring range is wrong (DIP switch).
- The setting of the alarm value is not in range of the choosen sensor typ.

The power LED and the alarm LED flashes in alternation.

The internal system test has reported a data error.

Remedy: push reset button.

- If the error signal continues please send the device back to the factory for examination.
- If the error signal don't continue, the device changes into an emergancy mode and operates possibly with lower precision. In this case the device should send back to the factory too.

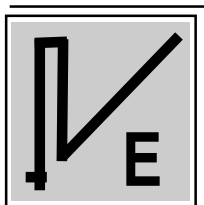

ELOTECH Industrieelektronik GmbH

Verbindungsstr. 27

D – 40723 Hilden

Tel. 02103 / 23055 Fax. 02103 / 23057

Internet <http://www.elotech.de>