



# ELOTECH

## R 1120 The Temperature Controller

Heat-only Controller  
Heating-off-Cooling Controller



DIN-Format: 96 x 96 mm  
Installation depth: 67 mm

## Description and Operating Manual

ELOTECH Industrieelektronik GmbH	
Verbindungsstraße 27	
D - 40723 HILDEN	
FON +49 2103 / 255 97 0	FAX +49 2103 / 255 97 29
www.elotech.de	Email: info@elotech.de

## 1. Contents

1.	Contents.....	2
2.	Installation Instructions .....	2
3.	Type Code.....	3
4.	Connection Diagram .....	3
5.	Display and Keyboard.....	4
6.	Operating Levels.....	6
7.	Configuration Level .....	7
8.	Parameter Level.....	10
9.	Operating Level.....	13
10.	Basic Level .....	14
11.	Technical Data .....	15
12.	Error displays.....	16

## 2. Installation Instructions

Make sure that the device is used for the intended purpose only.

This controller is designed for installation in control panels.

Protect the device against impermissible humidity and contamination.

Ambient temperature must not exceed 50 °C (122 °F).

Electrical connections must be made according to valid regulations and by properly qualified personnel.

If using thermocouple sensors, compensation lines have to be connected directly to the controller terminals.

Sensors may be connected only in compliance with the programmed range.

Sensor cables and signal lines (e.g. logic or linear voltage outputs) must be laid separately from control lines and mains voltage supply cables (power cables).

It is not permitted to connect the grounds of the sensor-inputs and logic-outputs with each other.

Separate installation of controller and inductive loads is recommended.

Interference from contactor coils must be suppressed by connecting adapted RC-combinations parallel to the coils.

Control circuits (e.g. for contactors) should not be connected to the mains power supply terminals of the controller.

The configuration parameters are generally to be selected first.

### Disclaimer of Liability

We have checked the contents of this document for conformity with the hardware and software described.

Nevertheless, we are unable to preclude the possibility of deviations so that we are unable to assume warranty for full compliance. However, the information given in the publication is reviewed regularly.

Necessary amendments are incorporated in the following editions.

We would be pleased to receive any improvement suggestions which you may have.

The information contained herein is subject to change without notice.

Electronic scrap and components are subject to special treatment and must be disposed of by authorized companies.

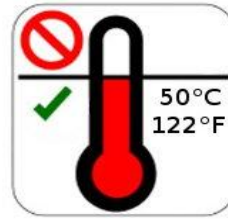

### 3. Type Code

R 1120 - x - 00 - z

- z: 1** Power supply: 230 V AC
  - z: 2** Power supply: 115V AC
  - z: 3** Power supply: 24V AC
  - z: 5** Power supply: 24V DC (+/-25%)
- 
- x: 10** Control output OUT1: Relay, control output „heating“ or „cooling“  
Output OUT2: Relay, control output „cooling“ or „alarm 2“ output  
Output OUT3: Relay, „alarm 3“ output
  - x: 20** Control output OUT1: Bist. Voltage, control output „heating“ or „cooling“  
Output OUT2: Relay, control output „cooling“ or „alarm 2“ output  
Output OUT3: Relay, „alarm 3“ output

### 4. Connection Diagram

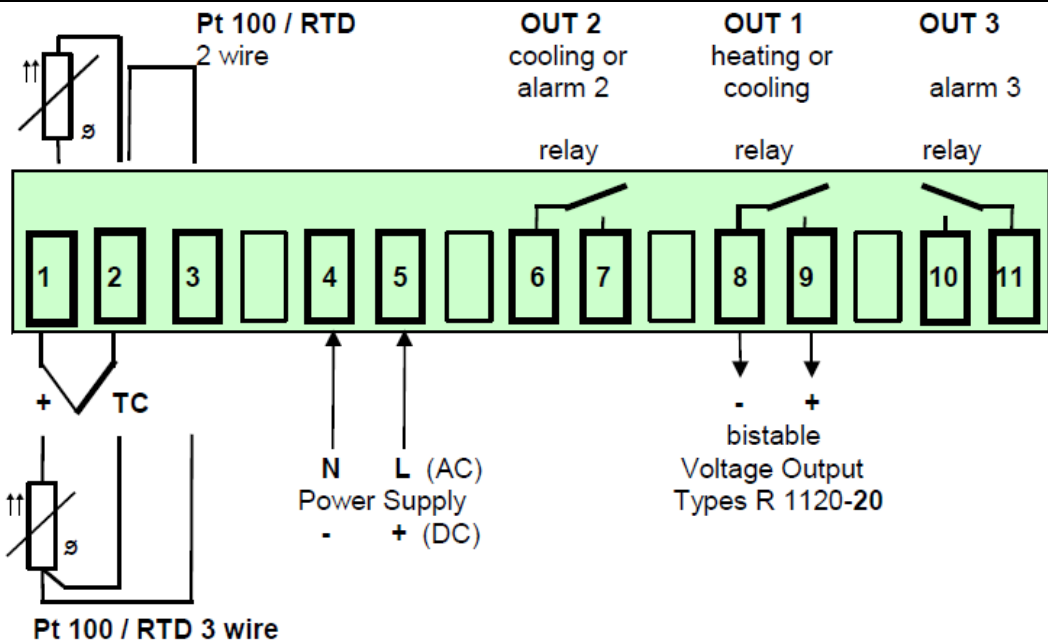

It is not permitted to connect the grounds of the sensor- and bistable voltage outputs with each other.

**Pt100-2 Wire: Bridge from terminal 2 to terminal 3**

**Control output OUT 1:**  
 2-point-controller: "Heating" e.g "Cooling"  
 3-point-controller (heating-off-cooling): "Heating"

**Control- or alarm output OUT 2:**

2-point-controller: "Alarm 2"  
3-point-controller: "Cooling"

**Alarm Output OUT 3:** "Alarm 3"

**5. Display and Keyboard**



Display	PROCESS	:	Process Value
Display	SET	:	Setpoint Value

<b>LED OUT 1:</b>	Output OUT1 active: Control Output
<b>LED OUT 2:</b>	Output OUT2 active: Control Output or Alarm Output A2
<b>LED OUT 3:</b>	Output OUT3 active: Alarm Output A3
<b>LED EDIT :</b>	Edit mode active: Parameter values can be adjusted

All the operations in the controller are carried out using a special rotatable knob. This knob can be turned in both directions and can also be pushed.

There are two types of knob (key) presses used:

Short press: With a short press it can be switched between parameter and edit mode.

Long press: This is used to switch between different operating levels. If the controller is in the edit mode, other levels cannot be reached.

**Parameter mode:**

In the operating, parameter and configuration level (see operating levels), the parameter is selected by turning the knob. In the basic level, only the parameter setpoint is available.

**Edit mode:**

From every parameter the edit mode is selected by a short press. In the edit mode, the parameter value can be changed by turning the knob. The parameter is saved by a short press. Simultaneously, the edit mode is cancelled.

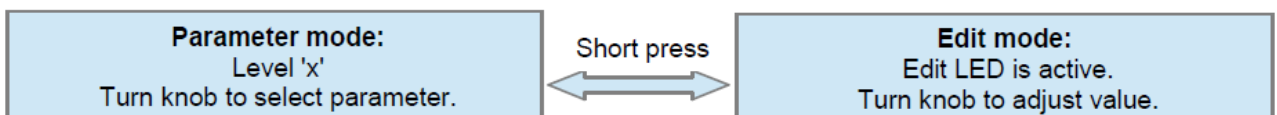



## 6. Operating Levels

The operation of the controller is divided into four levels.

After power on, the controller starts in the basic level.

Short press: < 1 s

Long press: > 2 s

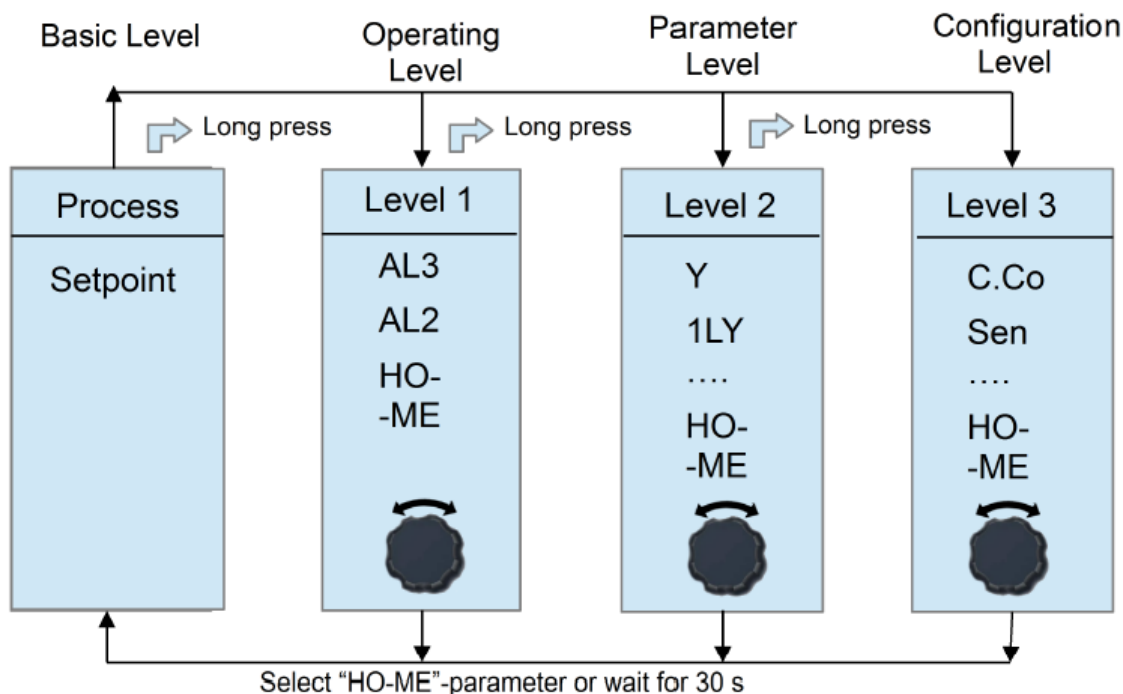

### Basic Level

Process and setpoint value will be displayed simultaneously.  
The setpoint can be adjusted.

### Operating Level

Here the alarms are set. The operating level can be reached from the basic level by a long key press. The parameters can be accessed by turning the knob. The alarm values can only be changed if the alarm configuration on the configuration level has been set.

### Parameter Level

In the parameter level the parameter values are adjusted to suit each individual process. This level is reached by a long knob press from the operating level.

### Configuration Level

In the configuration level the controller type, input type, sensor range, and the alarm behaviour can be selected.

**These adjustments have to be carried out first of all when starting the controller for the first time.**

The configuration level is reached by a long knob press from the parameter level.

Within the parameter- and the configuration level the parameters are selected and adjusted in the same way as on the operating level.

By selecting the "HO-ME" parameter or by waiting for a period of approx. 30 seconds, the unit will return to the basic level.

## 7. Configuration Level

Display "Process"	Parameter	Display "Set"	
<b>C.Co</b>	<b>Controller configuration</b>	2 h	2-point-controller "heating" (ex works)
		2 c	2point-controller "cooling"
		2nc	2point-controller "cooling" with non-linear cooling
		3	3-point controller "heating - off - cooling"
		3nc	3-point controller "heating - off - cooling" cooling mode with non-linear cooling*)

\*) non-linear cooling:  
Cooling action can be pre-selected with either linear or non-linear cooling response curve ( e.g. for vapour cooling).

<b>SEn</b>	<b>Sensor selection</b>	P1C	Pt 100,	0,0...99,9 °C
		P1F	Pt 100,	32...212 °F
		P2C	Pt 100,	-100...+200 °C
		P2F	Pt 100,	-148...+392 °F
		P4C	Pt 100,	0...400 °C (ex works)
		P4F	Pt 100,	32...752 °F
		P8C	Pt 100,	0...800 °C
		L4C	T/C Fe-CuNi (L),	0...400 °C
		L4F	T/C Fe-CuNi (L),	32...752 °F
		L8C	T/C Fe-CuNi (L),	0...800 °C
		J8C	T/C Fe-CuNi (J),	0...800 °C
		n1C	T/C NiCr-Ni (K),	0...999 °C

If the Sensor selection is changed, the following parameters will be reset (setting in brackets) and need to be readjusted:

The setpoint (OFF); the alarm value(s) (OFF); the process value offset (OFF); the lower setpoint limitation (SP.L); the higher setpoint limitation (SP.H).

**SP.H higher setpoint limitation**  
programming range: SP.L ... top range (ex works: 400)

**SP.L lower setpoint limitation**  
programming range: bottom range ... SP.H (ex works: 0)

**C.A3 Alarm 3-Configuration**  
(OUT 3)

OFF  
1  
2  
3  
4  
5  
6  
7

alarm OFF, no alarm signalisation (ex works)  
signal contact: off-on  
limit contact: off-on  
limit comparator: off-on-off  
signal contact: on-off  
limit contact: on-off  
limit comparator: on-off-on  
limit comp. with start-up suppression: off-on-off

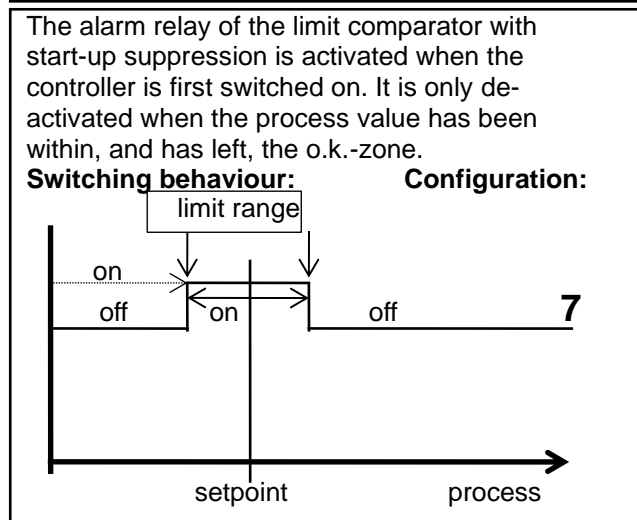
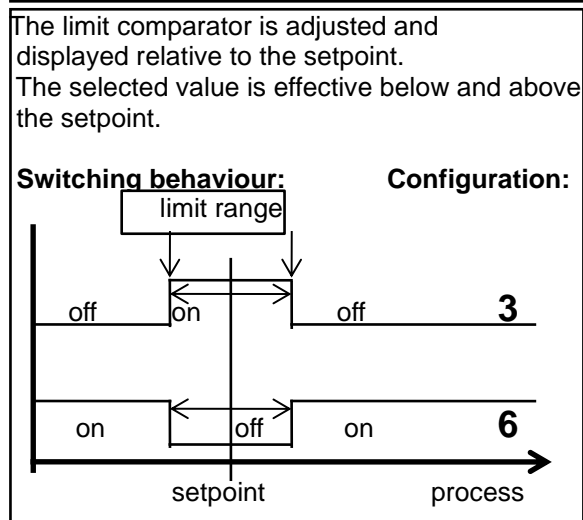
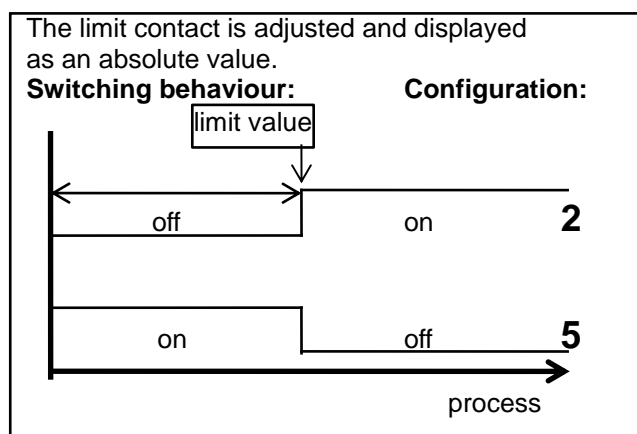
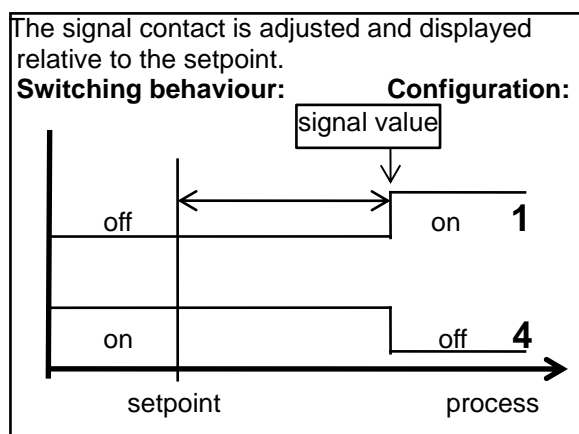

on: Relay "activated"  
off: Relay "not active"

**Please note:**

In case of sensor error the alarms will react in the same way as range override. The alarm contacts therefore do not offer protection against all types of *plant* breakdown. With this in mind, we recommend the use of a second, independent monitor unit.

Display "Process"	Parameter	Display "Set"
----------------------	-----------	------------------

---

The alarm 2 can only be configured if the parameter "C.Co" was set to a two point controller.

<b>C.A2 Alarm 2-Configuration</b> (OUT 2)	OFF	alarm OFF, no alarm signalisation (ex works)
	1	signal contact: off-on
	2	limit contact: off-on
	3	limit comparator: off-on-off
	4	signal contact: on-off
	5	limit contact: on-off
	6	limit comparator: on-off-on
	7	limit comp. with start-up suppression: off-on-off

<b>LOC Adjustment lock</b>	OFF	no adjustment lock (ex works)
	P C	parameter and configuration levels locked
	n.SP	all parameters apart from SP locked (not SP)
	ALL	all parameters locked

All parameters that have been locked with "LOC" can be selected and read, but not altered.

<b>r 1 2</b>		
<b>EL.x Control number</b>		Device R1120

**HO-** Select this parameter and press the knob to go back to the basic level.  
**-ME**

## 8. Parameter Level

Display "Process"	Parameter	Display "Set"
Y	<b>valid output ratio</b>	-99...100 % The output ratio shows the momentary calculated ratio. It cannot be altered. The display is in per cent of the installed performance capability for heating or cooling. Output ratio for cooling is shown as a negative value.
1LY	<b>OUT 1- output ratio limit</b>	0...100 % (ex works: 100)
2LY	<b>OUT 2- output ratio limit</b>	0...100 % (ex works: 100) Only adjustable if a heating-off-cooling mode is programmed.  A limitation of the output ratio is only necessary when: - the heating or cooling energy supply is grossly over-dimensioned compared to the power required, or - to turn off a control output (setting = 0 %). Under normal circumstances no limitation is needed (setting = 0 %). The limitation becomes effective when the controller's calculated output ratio is greater than the maximum permissible (limited) ratio. <b>Warning!</b> The output ratio limitation does not work during auto-tune.
1 P	<b>OUT 1- Xp prop. band (P)</b>	OFF; 0,1...99,9 % (ex works: 3,0) if Xp = OFF, the next parameter to follow is "1Sd" = control sensitivity OUT 1
1 d	<b>OUT 1- Tv rate (D)</b>	OFF; 1...200 s (ex works: 30)
1 J	<b>OUT 1- Tn reset (I)</b>	OFF; 1...999 s (ex works: 150)  Normally the controller works using PD/I control action. This means, controlling without deviation and with practically no overshoot during start-up. The control action can be altered in its structure by making the following adjustments to the parameters: a. no control action, on-off (setting P = OFF) b. P-action (setting D and I = 0) c. PD-action (setting I = 0) d. PI-action (setting D = 0) e. PD/I modified PID-action
1CY	<b>OUT 1- cycle time</b>	0,5...99,9 s (ex works: 15,0) The switching frequency of the actuator can be determined by adjusting the cycle time. This is the total time needed for the controller to switch on and off once. a) Relay outputs: cycle time > 10 s b) Bistable voltage outputs: cycle time 0,5...10 s

Display  
"Process"

Parameter

Display  
"Set"

Only if 1 P = OUT1 - Xp = OFF :

**1Sd control sensitivity OUT1:** OFF; 0,1...80,0 °C/°F (ex works: 0,1)

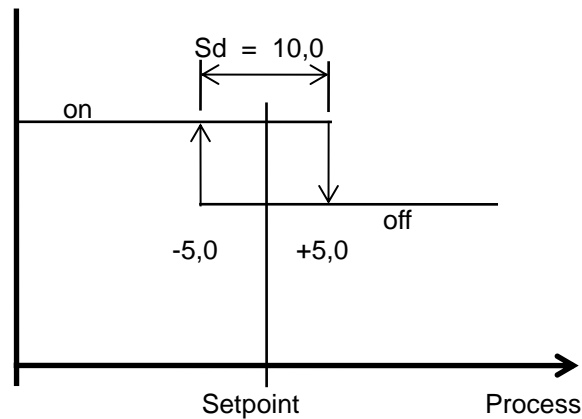

The following parameters apply only to the configuration of a heating-off-cooling controller:

<b>Sh</b>	<b>switch-point difference</b>	OFF; 0,1...80,0 °C/°F (ex works: OFF)	This parameter raises the setpoint (switch-point) for cooling output by the displayed value. It can be helpful to reduce the switching frequency between the heating and cooling outputs if this is too high. Simultaneous activation of heat and cool outputs is not possible.
<b>2 P</b>	<b>OUT 2- Xp cooling prop.-band (P)</b>	OFF; 0,1...99,9 % (ex works: 6,0) if Xp = OFF, the next parameter to follow is "2Sd" = control sensitivity OUT 2	
<b>2 d</b>	<b>OUT 2- Tv cooling rate (D)</b>	OFF; 1...200 s (ex works: 150)	
<b>2 J</b>	<b>OUT 2- Tn cooling reset (I)</b>	OFF; 1...999 s (ex works: 15,0)	
<b>2CY</b>	<b>OUT 2- cycle time cooling</b>	0,5...99,9 s (ex works: 15,0)	

Only if 2 P = OUT2 (cooling) - XP = OFF :

**2Sd control sensitivity OUT2** OFF; 0,1...80,0 °C/°F (ex works: 0,1)

**OPt self tuning**  
(auto-tune)

OFF self tuning out of action  
on self tuning on request ( one time)  
Auto self tuning automatically if the controller is switched on and if the difference between process value and setpoint is > 7 % of the range.

The tuning algorithm determines the characteristic values within the controlled process and calculates the valid feedback parameters ( P,D,I ) and the cycle time (  $C = 0.3 \times D$  ) of a PD/I-controller for a wide section of the range.

The determined parameters for heating are also adopted for cooling.

The self tuning activates during start-up shortly before the setpoint is reached. The setpoint must add up to at least 5 % of the total range.

If activated after the setpoint has already been reached, the temperature will first drop by approx. 5 % of the total range in order to detect the exact amplification of the process.

The tuning algorithm can be activated at any time by selecting the OPT = on and pressing the "E"-key. During self tuning "Opt" is shown in the display, alternating with the setpoint value.

Using the heat-cool controller, the temperature drop will be accelerated by switching on the cooling for a short duration.

After having calculated the correct feedback parameters, the controller will lead the process value to the setpoint.

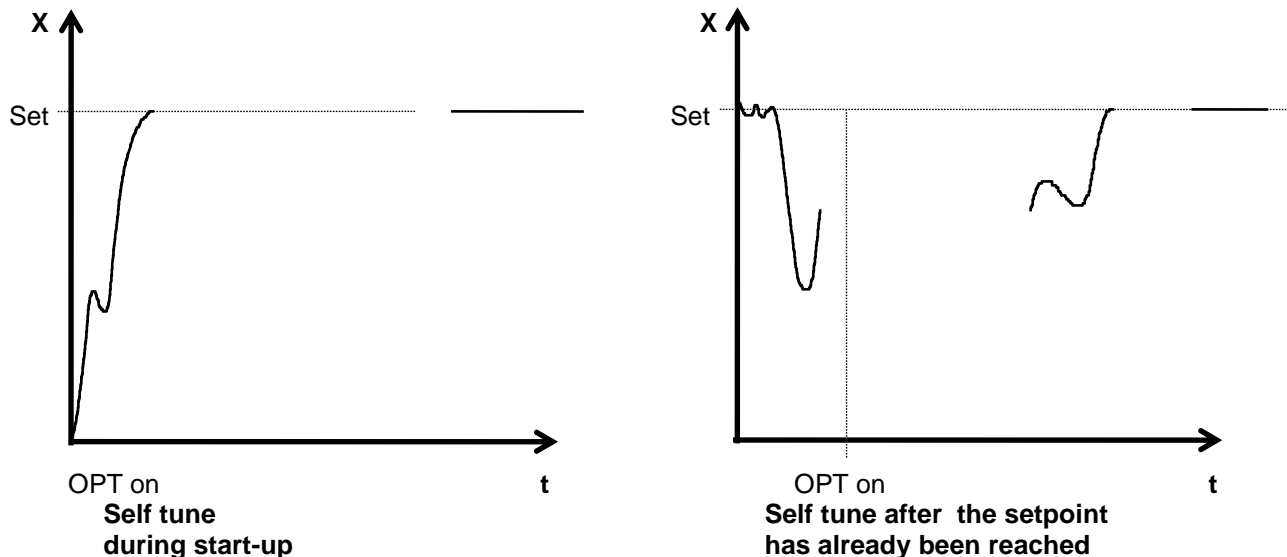

Self-tuning can be stopped by selecting the option OPT = OFF and pressing the "E"-key.

**OFS process value offset**      -199 ... OFF ...+199 °C/°F (ex works: OFF)  
   -19,9 ... OFF ... +19,9 °C/°F

This parameter serves to correct the input signal, e.g. for:

- the correction of a gradient between the measuring point and the sensor tip,
- the line resistance balancing of 2-line RTD (Pt100) sensors and
- correction of the control deviation when using P- or PD-action.

If for example the offset value is set to +5 °C, then the real temperature measured by the sensor (when process is balanced) is 5 °C less than the set-point and the displayed process value.

**HO-** Select this parameter and press the knob to go back to the basic level.  
**-ME**

## 9. Operating Level

Display "Process"	Parameter	Display "Set"
----------------------	-----------	---------------

---

The range of adjustment is dependent on the sensor and the alarm configuration.  
Both have to be set in the configuration level.

<b>AL3</b>	<b>Alarm 3, Out3</b>	(ex works OFF)
		signal contact, set-point dependent
		OFF; -199...199 °C/°F
		OFF; -19,9...+19,9 °C/°F
		limit comparator, set-point dependent
		OFF; 1...199 °C/°F
		OFF; 0,1...19,9 °C/°F
		limit contact, process value dependent
		OFF; range bottom ... range top

Alarm 2 is only available if the controller is programmed as a 2-point-controller in the configuration level.

<b>AL2</b>	<b>Alarm 2, Out2</b>	The adjustment is similar to alarm 3
------------	----------------------	--------------------------------------

<b>HO- -ME</b>	Select this parameter and press the knob to go back to the basic level.
--------------------	---

## 10. Basic Level

### Process

(process)

and

### Set-point

(set)

OFF, SP.L...SP.H

(ex works: 0)

**are displayed simultaneously (basic setting).**

If setpoint (SP) is set to "OFF", the controller switches to stand-by.

The process display then shows "OFF".

All main outputs are switched off and the alarm is deactivated.

All parameters can be displayed and altered during stand-by.

### Notes:

SP.L = lower set-point limitation

SP.H = upper set-point limitation

## 11. Technical Data

<b>Input Thermocouple:</b>	Built-in internal compensation point and protection against sensor break and incorrect polarity. Re-calibration not required for a line resistance of up to 50 ohm. Accuracy: $\leq 0,25 \%$
<b>Input RTD, Pt 100 (DIN):</b>	2- or 3-wire connection possible. Built-in protection against sensor break and short circuit. Max. permissible line resistance by 3-wire connection: 80 ohm Sensor current: $\leq 0,5 \text{ mA}$ Accuracy: $\leq 0,2 \%$
Linear error:	$\leq 0,2 \%$
Influence of the ambient temperature:	$\leq 0,01 \%$ / K
<b>OUT 1:</b>	R1120-10...: Relay, (n/o contact) max. 250 V AC, max. 3 A (resistive load) R1120-20...: bist. voltage signal, 0/18 V DC, max. 10 mA, short-circuit proof
<b>OUT 2:</b>	Relay, (n/o contact) max. 250 V AC, max. 3 A (resistive load)
<b>OUT 3:</b>	Relay, (n/o contact) max. 250 V AC, max. 3 A (resistive load)
<b>7-Segment-Display:</b>	Process: 10 mm red, Set: 10 mm red
<b>Data protection:</b>	EAROM
<b>CE-mark:</b>	EMC: 2004/108/EC, EN 61326-1 for industrial areas EN 61010-1
<b>Power supply:</b>	Standard: 230 V AC, $\pm 10 \%$ , 48...62 Hz
<b>Connections:</b>	Plug-in screw terminals, Protection mode IP 20 (DIN 40050), Insulation class C
<b>Permissible operating conditions:</b>	Operating temperature: 0...50 °C / 32...122 °F Storage temperature: -30...70 °C / -22...158 °F Climate class: KWF DIN 40040; equivalent to annual average max. 75 % rel. humidity, no condensation
<b>Casing:</b>	Format: 96 x 96 mm (DIN 43700), installation depth 67 mm Panel cutout: 92 +0,5 mm x 92 +0,5 mm Material: Noryl, self-extinguishing, non-drip, UL 94-V1 Protection mode: IP 20 (DIN 40050), IP 50 front side
<b>Weight:</b>	app. 400 g

Subject to technical improvements!

## 12. Error displays

<u>Display Cause</u>	<u>Possible remedy</u>
<b>SP.L</b> Lower set-point limit has been reached	Reduce limit, if need be
<b>SP.H</b> Upper set-point limit has been reached	Increase limit, if need be
<b>LOC</b> Parameter has been locked	Unlock, if need be
<b>Er.H</b> Top range end has been exceeded,	Check sensor and cable sensor defect
<b>Er.L</b> Bottom range end has been exceeded,	Check sensor and cable sensor defect
<b>C.A2</b> configuration of Alarm 2 is switched off	Set parameter "C.A2"
<b>C.A3</b> configuration of Alarm 3 is switched off	Set parameter "C.A3"
<b>Er.O</b> Self tuning error	Extinguish error signal by pressing the knob two times. Check the self tuning conditions and restart.
<b>Er.S</b> System error	Extinguish error signal by pressing the knob two times. Check all parameter values. If the error signal continues please send the controller back to the factory for examination.