



ELOTECH

R 1140 - 14 Three-Point Stepping Controller

**R 1140 - 64 Three-Point Stepping Controller
with analogue process value output**



Format: 48 x 96 mm (1/8-DIN)
Installation depth: 122 mm

Description and Operation Manual

ELOTECH Industrieelektronik GmbH
Verbindungsstrasse 27
D – 40723 HILDEN
FON +49 2103 / 255 97 0
www.elotech.de

FAX +49 2103 / 255 97 29
Email: info@elotech.de

Contents

Type code	Page	3
Connection diagram		4
Technical data		5
Display and keyboard		6
Operating levels, general		7
Configuration level		8
Parameter level		11
Operating level		13
Error displays		14
Installation instructions		14
Parameterlist		15

Please read this operating manual carefully before starting up.

Observe the installation and connecting instructions.

Before operation, the unit must be configured for its intended purpose under an expert guidance.

(e.g. sensor type and range, alarm adjustment etc.)

See: „Configuration Level“

Attention: The „open“- or „close“-outputs can be active while programming or configuring the controller. This can cause a damage either to the plant itself or its contents.

Disclaimer of liability

We have checked the contents of the document for conformity with the hardware and software described.

Nevertheless, we are unable to preclude the possibility of deviations so that we are unable to assume warranty for full compliance.

The information given in the publication is, however, reviewed regularly. Necessary amendments are incorporated in the following editions. We would be pleased to receive any improvement proposals which you may have.

The information contained herein is subject to change without notice.

Type Code

R 1140 - x4 - 0x - x

- ↓
- 1: Power supply: 230 VAC
2: Power supply: 115 VAC
3: Power supply: 24 VAC
5: Power supply: 24 VDC, +/-25%
- ↓
- 00: Sensor input, programmable:
Pt100(RTD), 2/3-wire connection;
Fe-CuNi (L); TypeJ, NiCr-Ni(K), Pt10Rh-Pt(S), **0-20mA; 4-20mA**
- 01: Sensor input, programmable:
Pt100(RTD), 2/3-wire connection;
Fe-CuNi (L); TypeJ, NiCr-Ni(K), Pt10Rh-Pt(S), **0-10VDC**
- ↓
- 14: **3-Point-stepping-controller** (e.g. to actuate motor valves)
OUT1: Relay and OUT4: bist. voltage 0/18VDC-signal
OUT2: Relay
OUT3: Relay
- 64: **3-Point-stepping-controller with analogue process value output 0/4-20mA**
OUT1: Relais
OUT2: Relais
OUT3: Relais

Connection diagram

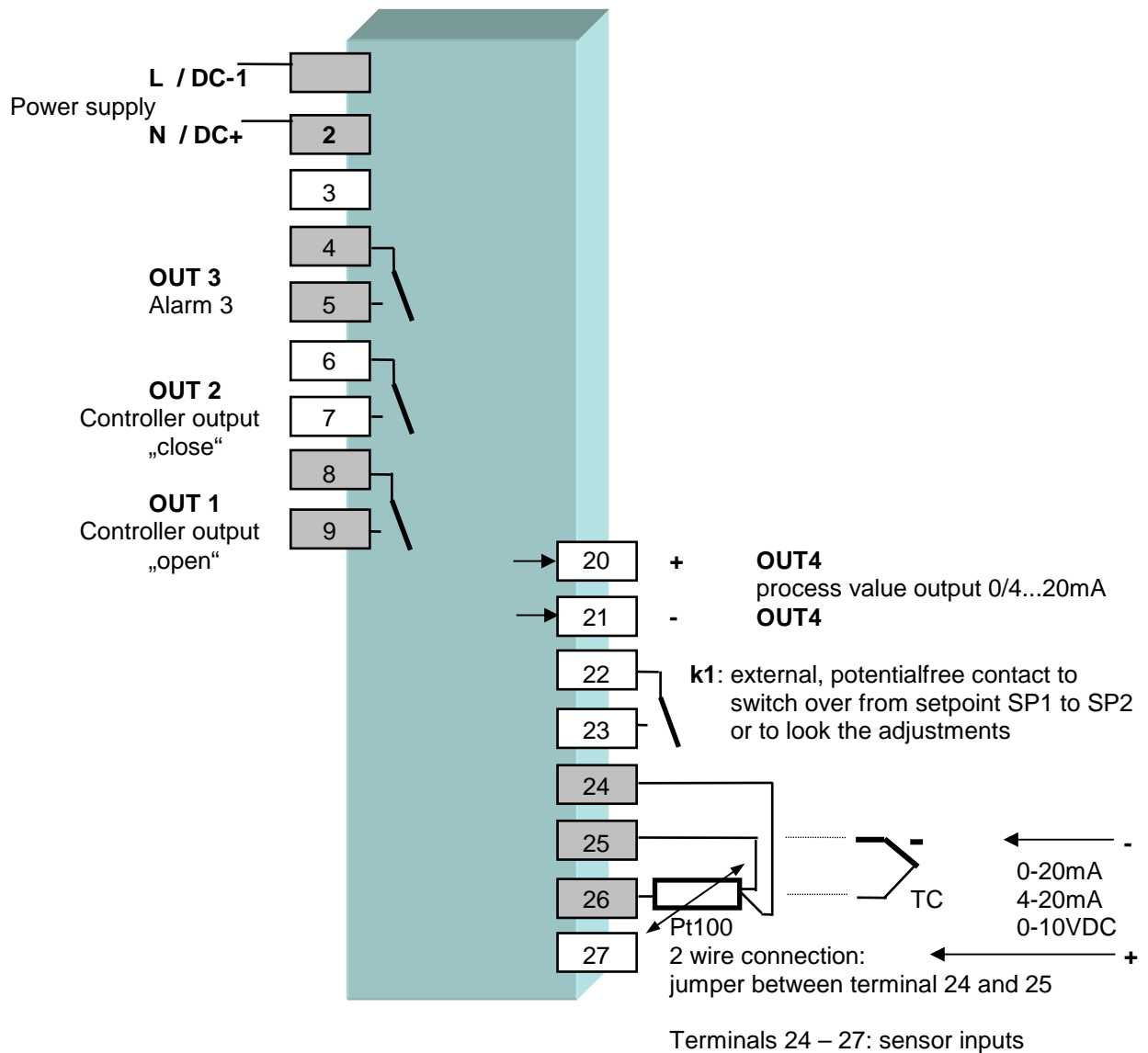

OUT1 = Control output "open"

OUT2 = Control output „close“

OUT3 = Alarm Output Alarm 3

OUT4 = Analogue actual process value output; see: parameter „Out4“

Function of contact k1: programmable. See parameter Co.c1. Possible adjustments: „Loc“ or „SP2“.

1. Adjustment lock (LOC):

k1: open = Adjustment lock only via "Software Code"

k1: closed = Adjustment locked (according to the chosen software code)

2. Setpoint Controlling:

k1: open = Setpoint 1 (SP1) valid

k1: closed = Setpoint 2 (SP2) valid

Technical Data

Input Thermocouple:	Built-in internal compensation point and protection against sensor breakage and incorrect polarity. Re-calibration not required for a line resistance of up to 50 Ohms. Calibration accuracy: $\leq 0,25\%$
Input RTD:	Built-in protection against sensor breakage and short circuit. Max. permissible line resistance by 3-wire connection: 80 Ohms Sensor current: $\leq 0,5$ mA Calibration accuracy: $\leq 0,2\%$
Standard signal inputs:	0-20mA, 4-20mA. Load: max. 500 OHm or 0-10VDC. Load: min. 10kOhm/ Volt
Linear error:	$\leq 0,2\%$
Influence of the ambient temperature:	$\leq 0,01\% / K$
Setpoint selection (k1):	Ext. potential-free contact, switching voltage appr. 24 V DC, max. 1 mA. Selection between SP1 (main setpoint) and SP2.
Process value output: OUT4	Version R1140-64: 0/4...20 mA, Load max. 500 Ohm according to the selected measuring range Linearity: $\leq 1,5\%$; Delay time: app. 2 secs.
Control outputs: OUT1, OUT2	Relay (UR appr.), max. 250 Vac, max. 3 A (cos-phi = 1)
Alarm output: OUT3	Relay (UR appr.), max. 250 Vac, max. 3 A (cos-phi = 1)
7-Segment-Display:	Process: 10 mm red, Set: 10 mm red
Data protection:	EAROM
CE-Mark	Tested according to 2004/108/EC; EN 61326-1 Electr. safety: EN 61010-1
Power supply:	Standard: 230 V AC. $\pm 10\%$, 48...62 Hz. 24VDC; +/-25% Others possible. See Type Code.
Connections:	Screw terminals (UR appr.). Protection mode IP 20 (DIN 40050), Insulation class C.
Permissible operating conditions:	Operating temperature: 0...50 °C / 32...122 °F Storage temperature: -30...70 °C / -22...158 °F Climate class: KWF DIN 40040; Equivalent to annual average max. 75 % rel. humidity. No condensation.
Casing:	Format: 48 x 96 mm (DIN 43700). Installation depth 122 mm Panel cutout: 45 +0,6 mm x 92 +0,8 mm Material: Noryl, self-extinguishing, non-drip, UL 94-V1 Protection mode: IP 20 (DIN 40050), IP 50 front side
Weight:	app. 380g

Subject to technical improvements!



Display **PROCESS:** Process Value
 Display **SET:** Setpoint Value

LED 1: Output OUT1 active: Control Output „open“

LED 2: Output OUT2 active: Control Output „close“

LED 3: Output OUT3 active: Alarm Output A3

LED SP2: Setpoint 2 active



Parameter key



Adjustment of chosen parameter (e.g. setpoint) to higher or lower values.
 E.g. setpoint adjustment.



Short operation: single-step adjustment

Longer operation: quick-scanning

When the parameter adjustments have been altered but not entered,
 the display will flash bright/dark.



Confirmation and storage of the pre-selected values

The display will shortly show a light chain as a control of this function.

To return to the process- and setpoint-display: press „E“ appr. 2 sec..



Sets the parameter back to the originally stored value.

Any alterations made to the parameters, that are not confirmed (E-key) within
 30 seconds, will not be accepted and the parameter will return to its originally
 stored value.

Operating Levels

The operation of the controller is divided into three levels.

Two seconds after switching on the unit, the controller will automatically be in the operating level.

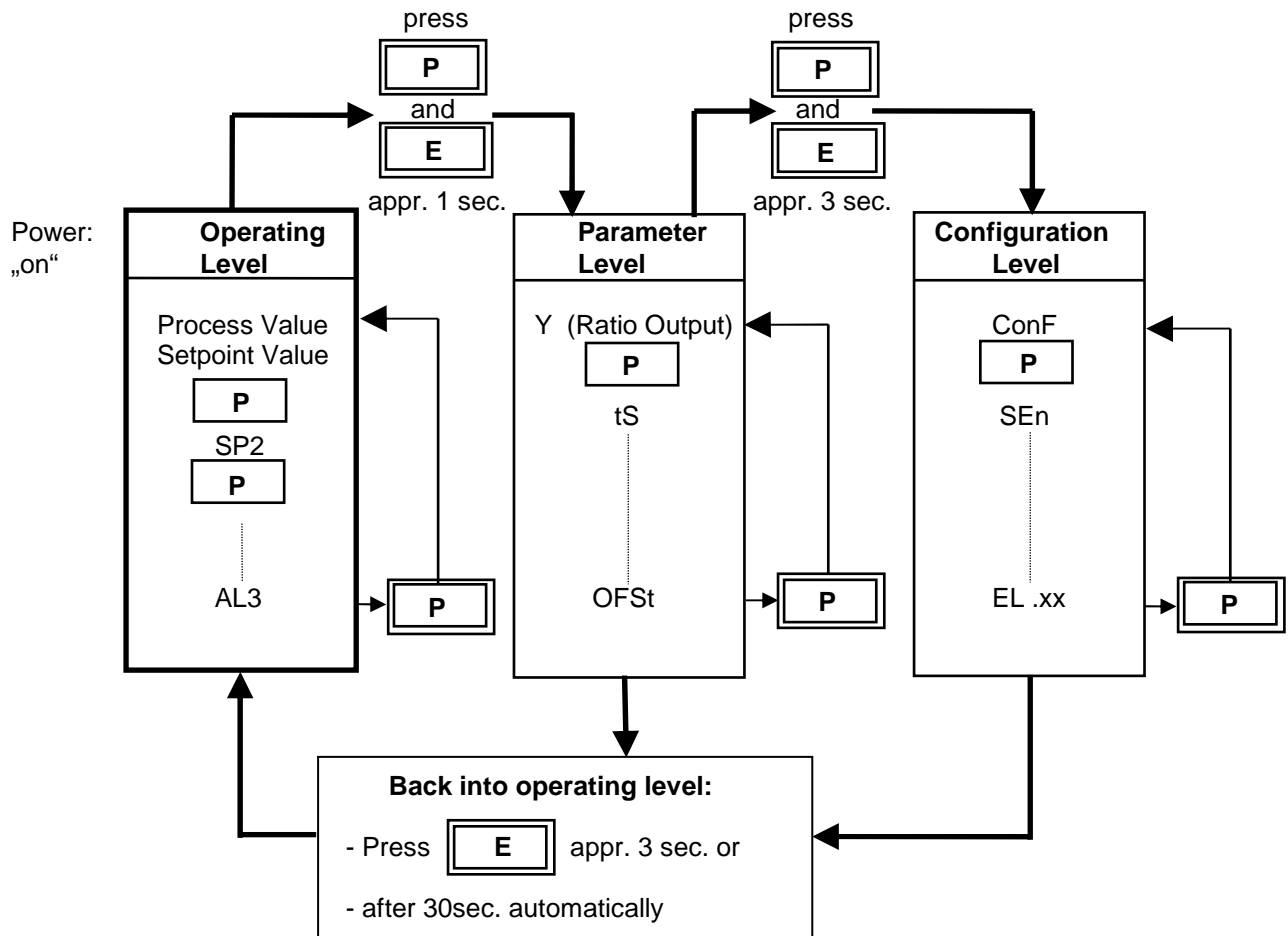

Operating level

Process- and setpoint value will be displayed simultaneously.

Within the operating level the setpoints and the alarm value can be adjusted by pressing the "▲" / "▼" - keys.

Every adjustment has to be quit by pressing the „E“ - key.

All parameters within the operating level can, in succession, be displayed by pressing the „P“ - key and adjusted by pressing the "▲" / "▼" - keys.

Parameter level

Enter this level by pressing the „P“ and „E“-key appr. 1 sec. simultaneously.

Within the parameter level the values are adjusted to suit the control behaviour to the individual process.

Leave this level by pressing key „E“ appr. 3 sec..

Configuration level

Enter this level by pressing the „P“ and „E“-key appr. 3 sec. simultaneously.

In the configuration level the controller type, sensor type, the sensor range, the alarm behaviour and the output type can be pre-selected.

This primary information has to be entered before taking the controller into operation.

The display of each single parameter within the parameter and configuration levels, and their adjustment, are made in the same way as within the operating level.

After either pressing the „E“ - key for approx. 3 seconds, or waiting for a period of approx. 30 seconds, the unit will automatically return to the operating level (display of process value and setpoint).

Display "Process"	Parameter	Display „Set“	
ConF	Controller configuration	3PSt	3-point-stepping controller (read-only parameter) This function is not adjustable.
Out4	Configuration output 4	Analogue process value output. Only Type R1140-64	
		Pr. 0	0...20mA (ex works)
		Pr. 4	4...20mA
Sen	Sensor selection	P1 °C	Pt 100, -50,0...100,0°C
		P1 °F	Pt 100, -58,0...212,0°F
		P2 °C	Pt 100, -100...200 °C
		P2 °F	Pt 100, -148...392 °F
		P4 °C	Pt 100, 0...400 °C (ex works)
		P4 °F	Pt 100, 32...752 °F
		P8 °C	Pt 100, 0...800 °C
		P8 °F	Pt 100, 32...1472 °F
		L4 °C	T/C Fe-CuNi (L), 0...400 °C
		L4 °F	T/C Fe-CuNi (L), 32...752 °F
		L8 °C	T/C Fe-CuNi (L), 0...800 °C
		L8 °F	T/C Fe-CuNi (L), 32...1472 °F
		J8 °C	T/C Fe-CuNi (J), 0...800 °C
		J8 °F	T/C Fe-CuNi (J), 32...1472 °F
		n1 °C	T/C NiCr-Ni (K), 0...1200 °C
		n1 °F	T/C NiCr-Ni (K), 32...2192 °F
		S1 °C	T/C Pt10Rh-Pt (S), 0...1600 °C
		S1 °F	T/C Pt10Rh-Pt (S), 32...2912 °F
		0 - 20	Current 0...20mA Voltage 0...10VDC (option 01)
		4 - 20	Current 4...20mA

If the Sensor selection is changed, the following parameters will be reset (setting in brackets) and need to be re-adjusted:

All Setpoints (set to OFF); ; alarm values (OFF); control sensitivity (0);
process offset(OFF); lower setpoint limitation (SP.Lo); higher setpoint limitation (SP.Hi).

The following parameters are only valid for standard signal inputs (0...20mA, 4...20mA). The difference between the bottom end of the display range and the top end must amount to a minimum of 100 units and a maximum of 2000 units. By adjustment of one of the above parameters, the other in this case will automatically follow.

rA.SP	decimal points	0; 1; 2	(ex works: 1)
rA.Hi	display range top end	rA.Lo ... 9999	(ex works: 100,0)
rA.Lo	display range bottom end	-1999 ... rA.Hi	(ex works: 0,0)

SP.Hi higher setpoint limitation SP.Lo ... top range (ex works: 400)

SP.Lo lower setpoint limitation bottom range ... SP.Hi (ex works: 0)

Co.A3 Alarm 3-Configuration
(OUT 3)

OFF
1
2
3
4
5
6
7

alarm OFF, no alarm signalisation (ex works)
signal contact: off-on
limit contact: off-on
limit comparator: off-on-off
signal contact: on-off
limit contact: on-off
limit comparator: on-off-on
limit comp. with start-up suppression: off-on-off

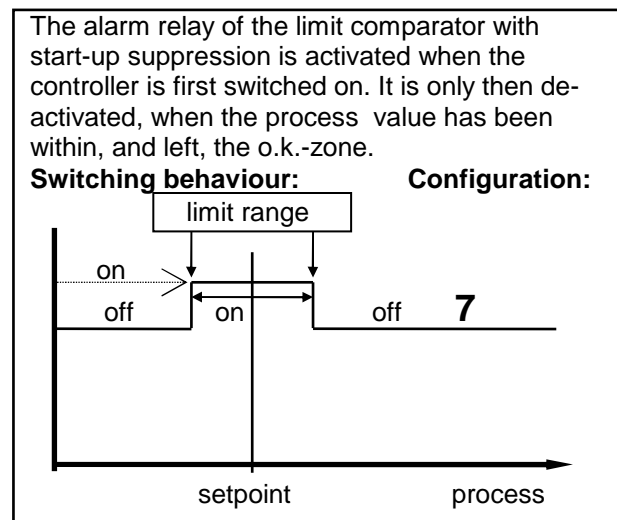
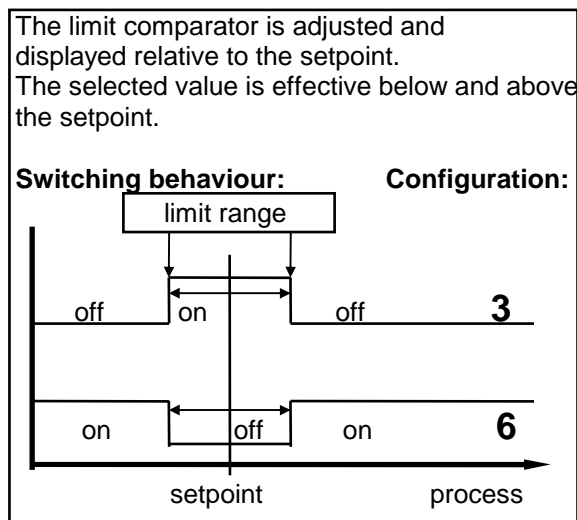
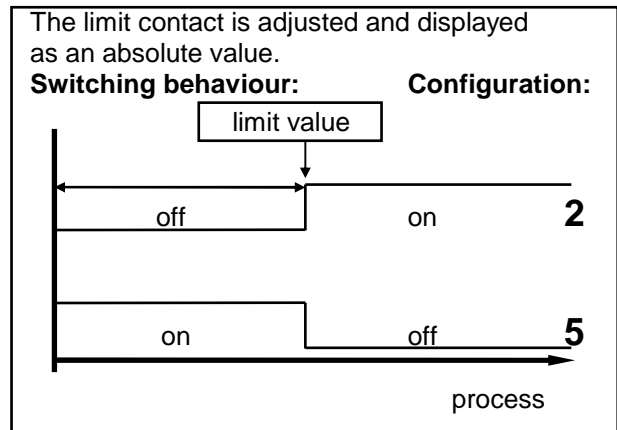
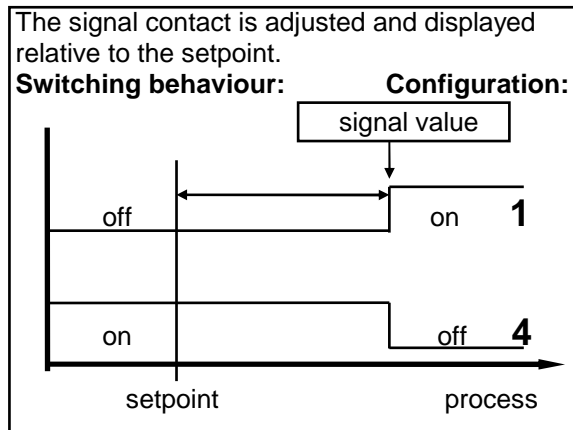

on: Relay "activated" or bistable voltage output "high".
off: Relay "not active" or bistable voltage output "low".

If a setpoint ramp has been programmed, the alarms that are relative to the setpoint (signal contact, limit comparator) follow the setpoint up the ramp.

Please note:

In case of sensor error the alarms will react in the same way as range override. The alarm contacts therefore do not offer protection against all types of plant breakdown. With this in mind, we recommend the use of a second, independent monitoring unit.

Display "Process"	Parameter	Display „Set“
Co.Sb Behaviour in event of sensor break		OFF OUT1 (open): off; OUT2 (close): off (ex works) 2 OUT1: off; OUT2: on 1 OUT1: on; OUT2: off
Co.c1 Function of external contact k1		Loc k1: open = Adjustment lock only via "Software Code" k1: closed = Adjustment locked = Adjustment locked (according to the chosen software code) SP2 k1: open = Setpoint 1 (SP1) valid k1: closed = Setpoint 2 (SP2) valid
LOC Adjustment lock		OFF no adjustment lock (ex works) P C parameter and configuration levels locked n.SP1 all parameters apart from SP1 locked (not SP1) ALL all parameters locked All parameters that have been locked with „LOC“ can be selected and read, but not altered. This adjustment cannot be changed if the external contact k1 is closed and if parameter „Co.c1“ = Loc
1140 EL.xx Control number		End of configuration level

Parameter Level

Display "Process"	Parameter	Display „Set“	
P	xp, prop.-band (P)	OFF; 1...200 %	(ex works: 10)
tS	Motor actuating time (d)	5 ... 800 secs	(ex works: 40)
tn	reset time (I)	0,5 ... 80,0 min.	(ex works: 3,0)
Sd	control sensivity	OFF; 0,1...80,0 units	(ex works: 0,1)
Sh	dead band	OFF; 0,1...80,0 units	(ex works: 0,1)

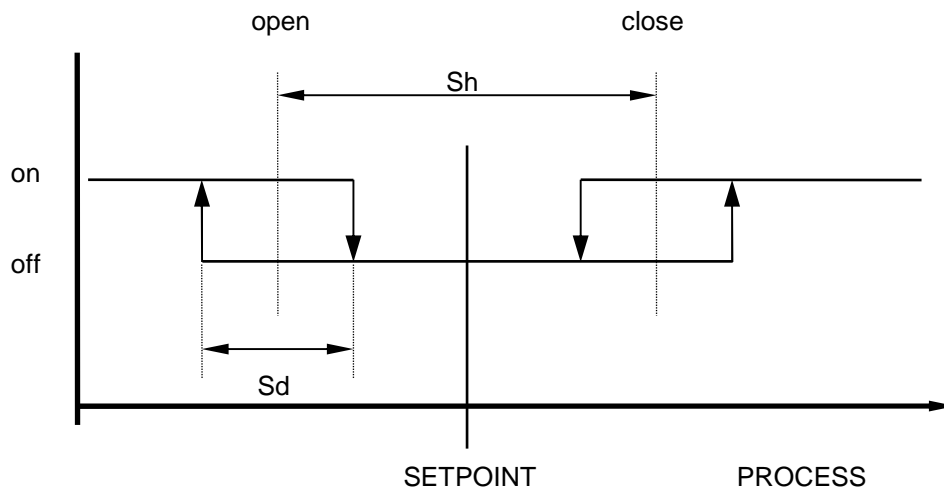

3-point-stepping controllers use PI control action in combination with motor actuators. It is important, that Sh should be several times larger than Sd. Switching frequency is dependant on the pre-selected feedback values.

Display "Process"	Parameter	Display „Set“
OPt	self tuning (autotune)	OFF self tuning out of action on self tuning on request (one time) Auto self tuning automatically if the controller is switched on and if the difference between process value and setpoint is > 7 % of the range.

The tuning algorithm determines the characteristic values within the controlled process, and calculates the valid feedback parameters (x_p , T_n) of a PI-controller.

The self tuning activates during start-up shortly before the setpoint is reached. The setpoint must amount to the least 5% of the total range.

If activated after the setpoint has already been reached, the temperature will first drop by approx. 5% of the total range, in order to detect the exact amplification of the process.

The tuning algorithm can be activated at any time by selecting the OPT=on and pressing the „E“-key. During self tuning „OPt“ is shown in the display, alternating with the setpoint value.

ATTENTION: While selftuning algorithm is active, the control outputs will force the actuators (e.g. the valves) to go on 100% (on) - and on 0% (off) - position.

After having calculated the correct feedback parameters, the controller will lead the process value to the setpoint.

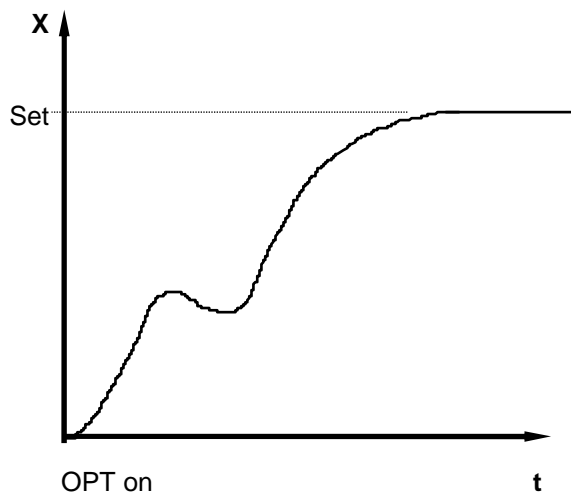

Self tune during start-up

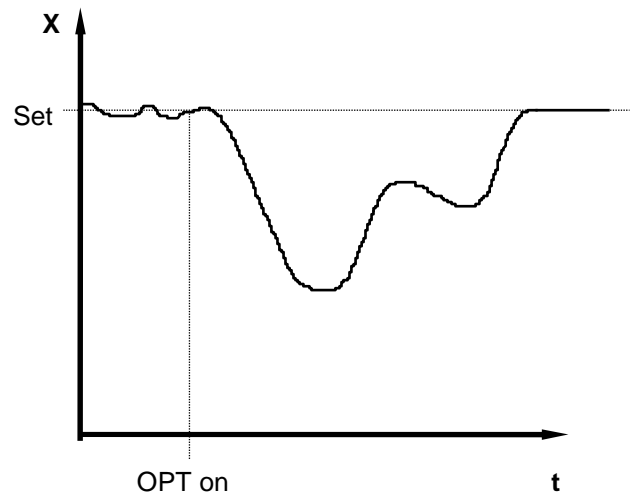

Self tune, after the setpoint has already been reached

Self-tuning can be stopped by selecting the option OPT = OFF and pressing the „E“ - key.

OFSt process value offset -999 ... OFF ...1000 °K (ex works: OFF)
-99,9 ... OFF ... 100,0 °K

This parameter serves to correct the input signal, e.g. for:

- the correction of a gradient between the measuring point and the sensor tip,
- the line resistance balancing of 2-line RTD (Pt100) sensors and
- correction of the control deviation when using P- or PD-action.

If for example the offset value is set to +5°C, then the real temperature measured by the sensor (when process is balanced) is 5°C less than the setpoint and the displayed process value.

Operating Level

Display "Process"	Parameter	Display "Set"
----------------------	-----------	---------------

Process
(process)

and

Setpoint 1 (set)	OFF, SP.Lo...SP.Hi	(ex works: 0)
----------------------------	--------------------	---------------

are displayed simultaneously (basic setting).

If setpoint 1 (SP1) is set to "OFF", the controller switches to stand-by.
The setpoint display then shows "OFF". All main outputs are switched off and the alarm is de-activated.
All parameters can be displayed and altered during stand-by.

SP2 Setpoint 2	OFF; SP.Lo SP.Hi	(ex works: OFF)
-----------------------	------------------	-----------------

The 2. setpoint is active when the external contact K1 is closed.
The corresponding LED „SP2“ lights up on the faceplate, and the second set-point is shown in the display.“
Please note, that the value of the second setpoint cannot be changed in the operating level.
In order to change the value the parameter SP2 has to be selected.

AL 3 Alarm 3, Out3	signal contact, setpoint dependent	
	OFF; -999...1000 ⌘	(ex works)
	OFF; -99,9...100,0 ⌘	

	limit comparator, setpoint dependent	
	OFF; 1...1000 ⌘	(ex works)
	OFF; 0,1...100,0 ⌘	

	limit contact, process value dependent	
	OFF; range bottom ... range top	

The range of adjustment is dependant on the sensor and the alarm configuration.
Both have to be set in the configuration level.

Hand manual mode	OFF: The instrument is operating like a controller	(ex works)
	On : The instrument operates only as an actuator	

„On“:

Display „process“ : the actual process value is displayed.

Display „set“ : the word **HA** will be displayed, instead of the setpoint.

Press key „ up „: OUT1 (open) is activated

Press key „down“: OUT2 (close) is activated

In the mode “HA = on” the setpoint can not be adjusted.

Error displays

<u>Display</u>	<u>Cause</u>	<u>Possible remedy</u>
SP.Lo	Lower setpoint limit has been reached	Reduce limit, if need be
SP.Hi	Upper setpoint limit has been reached	Increase limit, if need be
LOC	Parameter has been locked	Unlock, if need be
Er.Hi	Top range end has been exceeded, sensor defect	Check sensor and cable
Er.Lo	Bottom range end has been exceeded, sensor defect	Check sensor and cable
Er.OP	Self tuning error	Extinguish error signal by pressing the „E“-key. Check the self tuning conditions and restart.
Er.SY	System error	Extinguish error signal by pressing the „E“-key. Check all parameters. If the error signal continues please send the controller back for examination.

Installation Instructions

Make certain that the devices described here are used only for the intended purpose.

They are intended for installation in control panels.

The controller must be installed so that it is protected against impermissible humidity and severe contamination.

In addition, make sure that the permitted ambient temperature is not exceeded.

The electrical connections must be made according to the relevant locally applicable regulations.

If using a thermocouple sensor, the compensation cables must be laid directly to the controller terminals.

Transducers must be connected only in compliance with the programmed range.

Transducer cables and signal lines (e.g. logic or linear voltage outputs) must be laid physically separated from control lines and mains voltage supply cables (power cables).

To keep the CE-conformity it is necessary, to use for sensor- and low voltage signal lines shielded cables. Spatial separation between controller and inductive loads is recommended.

Interference from contactor coils must be suppressed by connecting adapted RC-combinations parallel to the coils. Control circuits (e.g. for contactors) should not be connected to the mains power supply terminals of the controller.

IMPORTANT:

Before operation, the unit must be configured for its intended purpose

(e.g. sensor type and range, alarm adjustment etc.). Please see „Configuration Level“.

Parameter Adjustments

1. Configuration level:	Ex works:	Customers adjustments:
ConF Controller Configuration	3PSt	
Out4 Configuration Out4	Pr.0 0...20mA	
SEn Sensor Configuration	P4 °C (0.400°C, RTD)	
SP.Hi Upper Setpoint Limitation	400	
SP.Lo Lower Setpoint Limitation	0	
Co.A3 Alarm 3-Configuration	OFF	
Co.Sb Behaviour in event of sensor break	OFF	
Co.c1 Function of external contact k1	Loc	
LOC Adjustment lock	OFF	
1140 Control number: EL.xx	read only	

2. Parameter level:	Ex works:	Customers adjustments:
P Proportional band (P)	10,0	
tS Motor actuating time ,Rate (D)	40	
tn Reset time (I)	3,0	
Sd OUT 1/4- Control sensitivity	0,1	
Sh Switch-point difference	0,1	
OPt Self tuning	OFF	
OFSt Process value offset	OFF	

3. Operating level:	Ex works:	Customers adjustments:
Actual process value (process)	read only	
Setpoint (set)	0	
SP2 Setpoint 2	OFF	
AL3 Alarm point 3	OFF	
AL2 Alarm point 2	OFF	

