

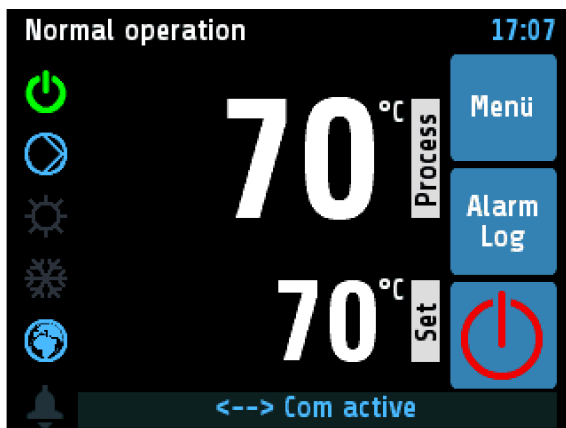

**ELOTECH**  
INDUSTRIELELEKTRONIK

## RS4100 or RS4110

Controller for Temperature Control Systems



## DESCRIPTION AND OPERATING MANUAL

ELOTECH Industrieelektronik GmbH  
Verbindungsstraße 27  
D - 40723 HILDEN  
Phone +49 2103 / 255 97 0  
www.elotech.de

Fax +49 2103 / 255 97 29  
E-Mail: info@elotech.de

# Table of Contents

|          |  |    |
|----------|--|----|
| 1        | General Information .....  | 4  |
| 2        | Installation Instructions .....  | 4  |
| 3        | Type Codes.....  | 6  |
| 3.1      | Type Code of Controller .....  | 6  |
| 3.2      | Type Code of IO-Board .....  | 6  |
| 4        | Connection Diagrams.....   | 7  |
| 4.1      | Connection Diagram IO-Board.....   | 7  |
| 4.1.1    | Wiring examples.....   | 8  |
| 4.1.1.1  | Level control and motor protection: .....                                | 8  |
| 4.1.1.2  | Cooling, filling and draining solenoid valves .....                      | 8  |
| 4.1.1.3  | Pump Q1 and pump left K1 contactor *K1 if reverse running is needed..... | 8  |
| 4.1.1.4  | Heating SSR (SSR1/SSR2) and enable heating contactor (Q2).....           | 9  |
| 4.2      | Connection Diagram Hybrid Module .....                                   | 9  |
| 4.3      | Connection Diagram Controller .....                                      | 10 |
| 4.4      | Connection Diagram Fieldbus Modules .....                                | 11 |
| 4.5      | Connection Diagram: LAN and USB.....                                     | 11 |
| 5        | Operating the device .....   | 12 |
| 5.1      | General advises regarding GUI .....                                      | 12 |
| 5.1.1    | Entry of numerical values .....  | 12 |
| 5.1.2    | Activate / deactivate functions.....                                     | 13 |
| 5.1.3    | Handling of listings .....   | 13 |
| 5.1.4    | Entry of text.....   | 14 |
| 5.1.5    | Menu layout.....   | 15 |
| 5.2      | Menus .....  | 16 |
| 5.2.1    | Operating Mode display (Home).....                                       | 16 |
| 5.2.2    | Main Menu .....  | 17 |
| 5.2.3    | Menu „Functions“ .....   | 18 |
| 5.2.3.1  | Autotune .....   | 19 |
| 5.2.4    | Menu „Process“ .....   | 20 |
| 5.2.5    | Menu „Pump“ .....  | 20 |
| 5.2.6    | Menu „Alarms“ (Event Monitoring) .....                                   | 21 |
| 5.2.7    | Menu „Configuration Monitoring“ .....                                    | 21 |
| 5.2.7.1  | Configuration of temperature monitoring.....                             | 22 |
| 5.2.8    | Menu „Alarm Log“ .....   | 23 |
| 5.2.9    | Menu „Graph“ .....   | 24 |
| 5.2.10   | Menu „Program“ (Program controller graph).....                           | 24 |
| 5.2.10.1 | Setting of program controller.....                                       | 25 |
| 5.2.11   | Menu „Parameters“ .....  | 27 |
| 5.2.11.1 | Tool (equipment) selection.....  | 27 |
| 5.2.11.2 | Setpoint 2.....  | 27 |
| 5.2.11.3 | Configuration Heating / Cooling .....                                    | 27 |
| 5.2.12   | Control Parameters .....   | 28 |
| 5.2.13   | Heating Control Parameters .....   | 28 |

|          |   |    |
|----------|---|----|
| 5.2.14   | Cooling Control Parameters.....                   | 29 |
| 5.2.14.1 | Ramps.....  | 30 |
| 5.2.14.2 | Cool down temperature.....                        | 30 |
| 5.2.14.3 | Maximal filling time.....                         | 30 |
| 5.2.14.4 | Drainage time .....                               | 30 |
| 5.2.15   | Offsets and setpoint limits .....                 | 31 |
| 5.2.16   | Menu „System“ .....                               | 31 |
| 5.2.17   | Menu for Common Settings (General Settings) ..... | 31 |
| 5.2.18   | Menus Fieldbus / USB / LAN.....                   | 33 |
| 5.2.19   | Menu About.....                                   | 37 |
| 6        | Error Messages .....                              | 38 |
| 7        | Technical Data .....                              | 39 |

# 1 General Information

Symbols used:

|                        |   |
|------------------------|---|
| <b>www.elotech.de</b>  | Messages shown by the controller are written in this font.      |
| <b>MRS / MRE</b>       | <b>Measuring Range Start / Measuring Range End</b>              |
| <b>&lt;Default&gt;</b> | Symbolizes the factory adjustment of the respective parameters. |

## 2 Installation Instructions

Make sure the device is used for the intended purpose only.

The devices of type R4100-C are designed for installation in control panels, the I/O-Boards of type R4100-M are designed to be mounted on cap rails.

Protect the device against impermissible humidity and contamination.

The permitted ambient temperature range may not be exceeded.

Electrical connections must be made according to valid regulations and by properly qualified personnel.

If using thermocouple sensors, compensation lines have to be connected directly to the controller terminals. Sensors may be connected only in compliance with the programmed range.

Sensor cables and signal lines (e.g. logic or linear voltage outputs) must be placed separately from control lines and mains voltage supply cables (power cables).

In order to maintain EMC compliance screened detectors - and signal lines have to be used.

It is not permitted to connect the grounds of the sensor-inputs and logic-outputs with each other.

Spatial separation of RS4100 devices and inductive loads is recommended. Interference from contactor coils must be suppressed by connecting adapted RC-combinations parallel to the coils. Control circuits (e.g. for contactors) should not be connected to the mains power supply terminals of the RS4100 devices.

The configuration parameters (Window: System) are generally to be selected first.

## Disclaimer of Liability

The contents of this document is checked for the conformity with the hardware and software described. Nevertheless, we are unable to preclude the possibility of deviations so that we are unable to assume warranty for full compliance. However, the information given in the publication is reviewed regularly. Necessary amendments are incorporated in the following editions.

We would be pleased to receive any improvement proposals which you may have.

The information contained herein is subject to change without notice.

## Disposal

Electronic scrap and components are subject to special treatment and must be disposed of by authorised companies.

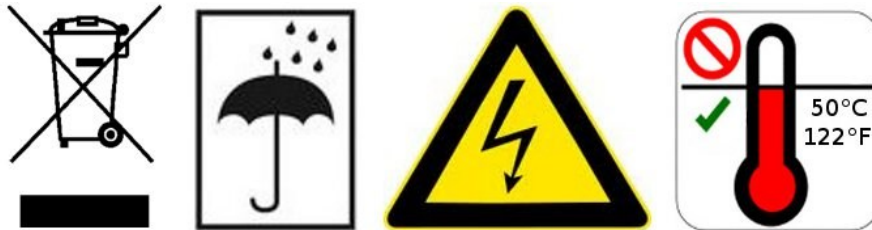

# 3 Type Codes

## 3.1 Type Code of Controller

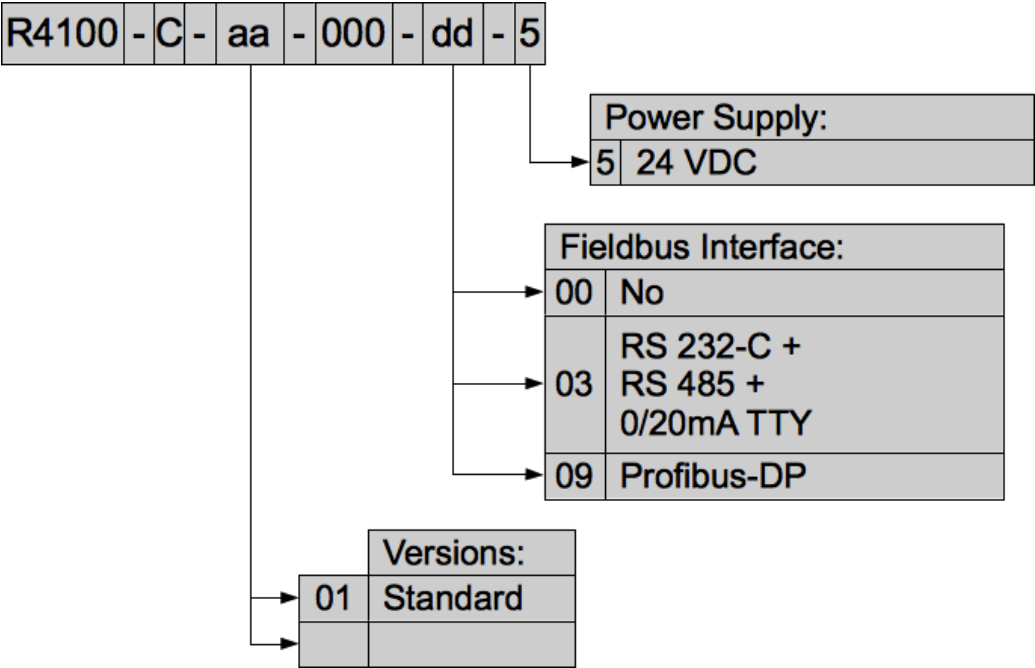

## 3.2 Type Code of IO-Board

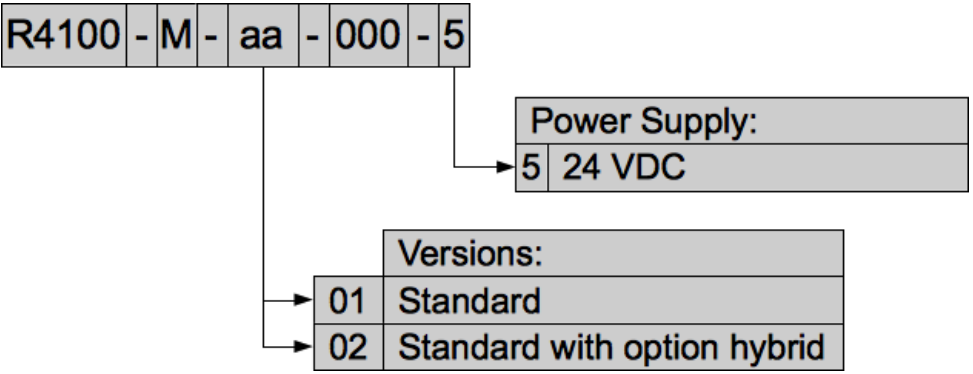

## 4 Connection Diagrams

### 4.1 Connection Diagram IO-Board

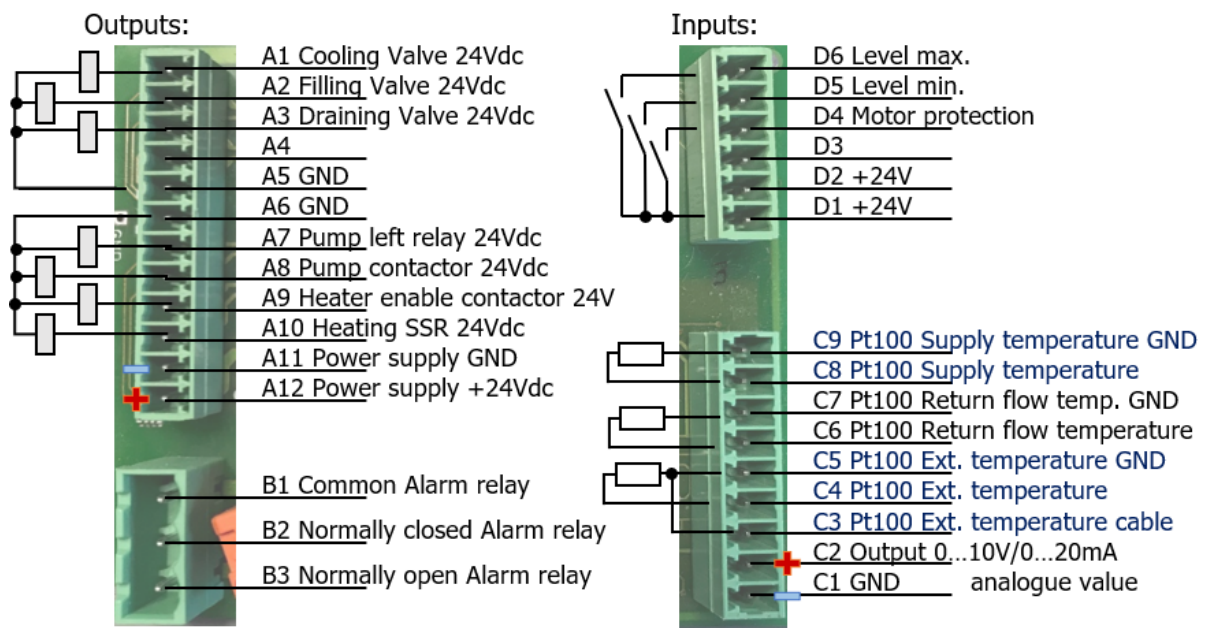



#### 4.1.1.4 Heating SSR (SSR1/SSR2) and enable heating contactor (Q2)

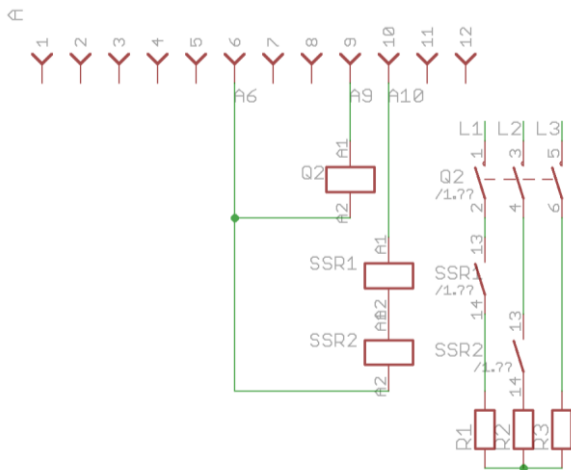

The "Heater Enable" output is used to integrate an external safety circuit that allows the power supply to the heating outputs to be reliably disconnected in the event of a fault. Functionality:

- The output controls a pre-contactor
- If a safety-relevant condition occurs (e.g. temperature limit exceeded, motor protection triggered), the pre-contactor is deactivated
- This interrupts the power supply to the heating elements

Important Note:

The "Heater Enable" output is not a control or modulation output for directly operating heaters. It is used exclusively for safety interlocking.

## 4.2 Connection Diagram Hybrid Module

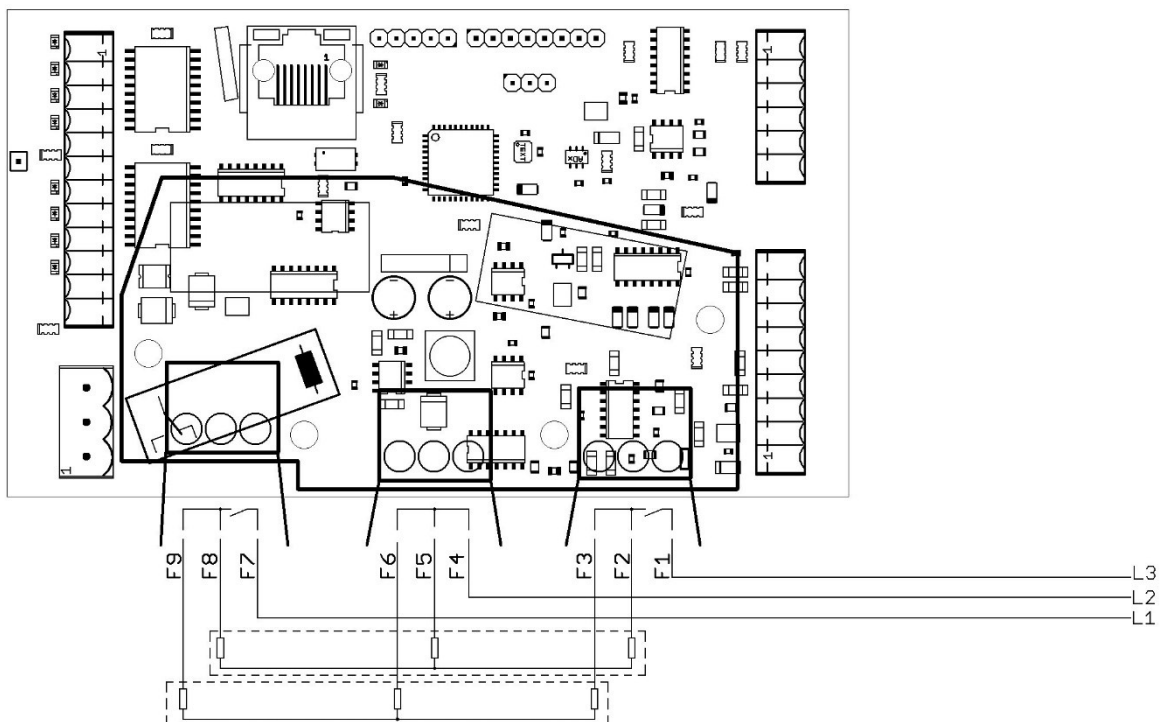

### 4.3 Connection Diagram Controller

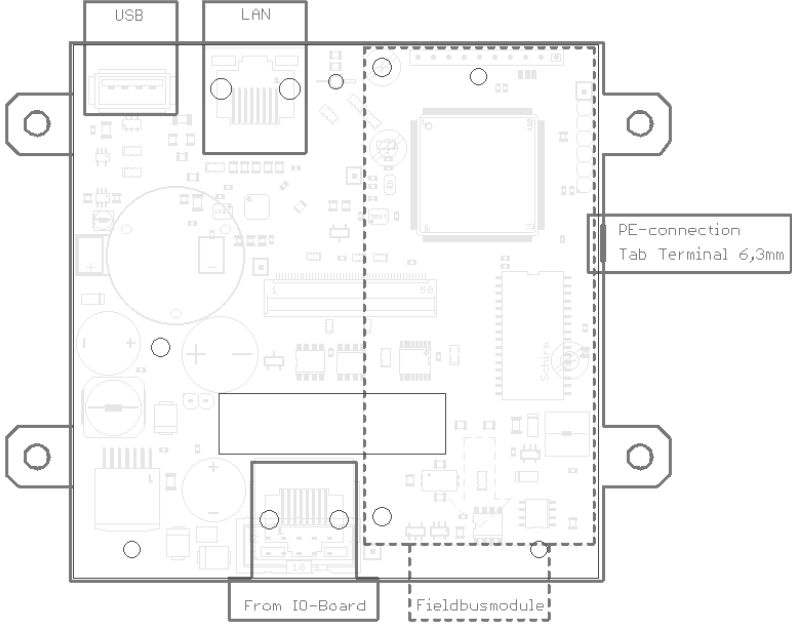

## 4.4 Connection Diagram Fieldbus Modules

### Serial Interface

| L1 L2 L3 L4 L5 L6 L7 |   |   |     |     |     |   | Bus   | Type | Remark                                   |
|----------------------|---|---|-----|-----|-----|---|-------|------|--|
|                      | A | B |     |     |     |   | RS485 | 03   | Parameter HW-config = RS232 / RS485      |
|                      |   |   | RxD | TxD | GND |   | RS232 | 03   | Parameter HW-config = RS232 / RS485      |
|                      |   |   |     |     | -   | + | TTY   | 03   | Parameter HW-config = TTY (current loop) |
|                      |   |   |     |     |     |   |       |      |  |

The serial fieldbus module contains the three interfaces RS232, RS485 and TTY. By choosing the connection and setting the parameter "HW-config" the requested bus is selected.

### Type 09: Profibus

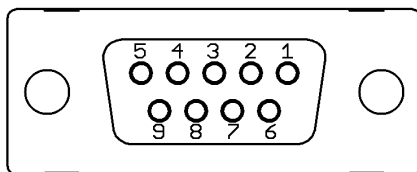

|       |                    |
|-------|--------------------|
| Pin 3 | Data RxD / TxD - P |
| Pin 5 | GND                |
| Pin 6 | +5V                |
| Pin 8 | Data RxD / TxD - N |

The 5V-Supply is designed for the supply of the termination resistors. Further loads are not allowed.

## 4.5 Connection Diagram: LAN and USB

### USB:

- Save process data, configuration data and alarm data on an USB-Stick.
- Write back configuration data from USB-Stick to the controller.
- Make a Firmware update. (Please use FAT formatted USB flash drives.)

### LAN:

- Connection to configuration tool **EloVision 3**.
- Read and write parameters by MODBUS-TCP protocol
- Web interface for easy configuration

# 5 Operating the device

## 5.1 General advises regarding GUI

The device R4100-C provides a high-contrast colour screen with touch functionality.

After switching on the devices R4100-C and R4100-M and after completion of the initialization, the actual temperature value and the setpoint are displayed.

The device R4100-C is operated by menus. The different parameters are displayed mainly in plain text and can be displayed in English and German language.





In the following the general methods of data and commands entry are explained:

### 5.1.1 Entry of numerical values

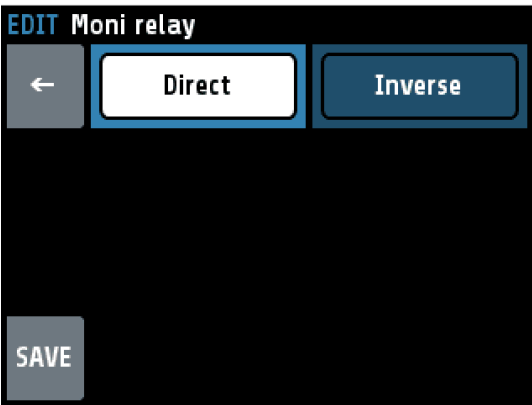

|  |  |
|--|--|
|  | <p>The header displays on the left the current adjustable parameter (this example: setpoint 1)</p> <p>By pressing the number keys the value of the parameters can be entered.</p> <p>By pressing the "SAVE"- key the entered value will be set.</p>  |
|  | <p>The value, entered by pressing the number keys, is displayed within the blue frame.</p> <p>Underneath, on the left the unit is shown and the previous value is displayed on the right (250).</p> <p>The allowed range is displayed at the bottom (0...800).</p>   |
|  | <p>If this Button is visible, two adjustable parameters are available. Such as: upper limit / lower limit or rising ramp / falling ramp Switch over by pressing this button. The name of the actually adjustable parameter is displayed in the header. After adjusting one parameter the window will not be closed and the second parameter can be adjusted.</p> |
|  | <p>This key is visible when the parameter has a valid value "OFF". "OFF" can be selected like a number key.</p>  |
|  | <p>Number key</p>  |
|  | <p>Key to enter "Minus" or "Comma". The minus sign can be pressed before entering a number. After the first number was entered the key automatically changes to comma.</p>   |
|  | <p>Delete last character</p>   |
|  | <p>Return to previous window</p>   |

|   |   |
|---|---|
|  | Saving of entered data and returning to previous window |
|---|---|





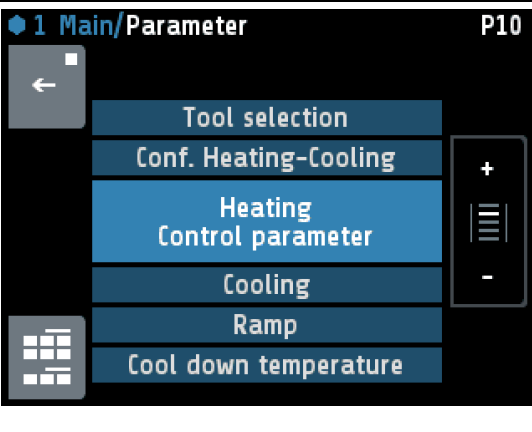

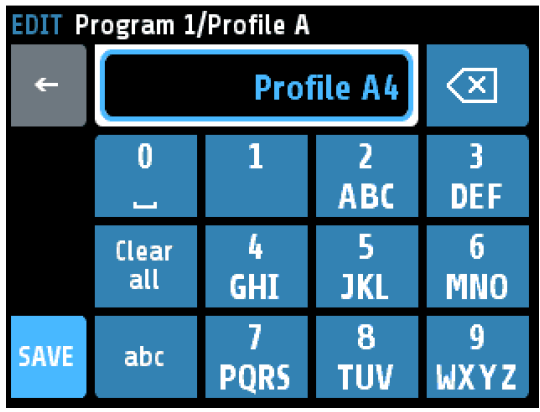

### 5.1.2 Activate / deactivate functions

|   |  |
|---|--|
|    | <p>By pressing the tile key, the function can be selected.</p> <p>Black text on a white background is used to display the selected element.</p> <p>In order to activate the selected function, the "SAVE"-key needs to be pressed.</p> |
|    | Selected element: Black text on a white background   |
|   | Element not selected: White text on a blue background  |
|  | Saving of selection and return to previous window  |
|  | Return to previous window  |

### 5.1.3 Handling of listings

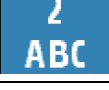
|   |  |
|---|--|
|  | <p>The header displays the name of the listing, here "Parameter".</p> <p>The currently selected submenu is displayed in the middle with light blue background. In order to open the selected submenu please press on the tile.</p> <p>By pressing the +/- Buttons on the right (or pressing the upper or lower areas of the list) the list can be slid up or down.</p> |
|  | Jump to menu „Main“  |
|  | Return to previous window  |

## 5.1.4 Entry of text





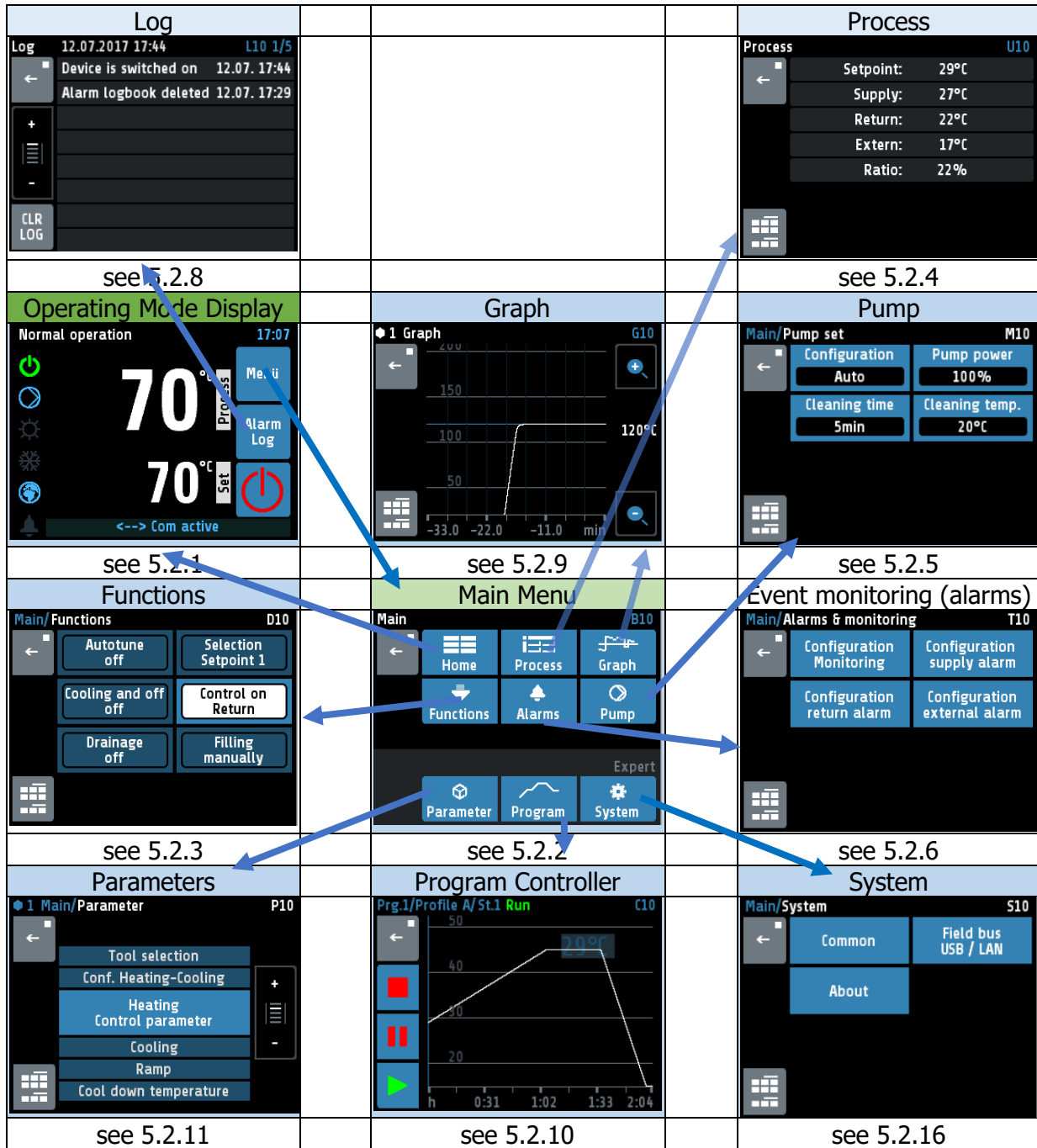



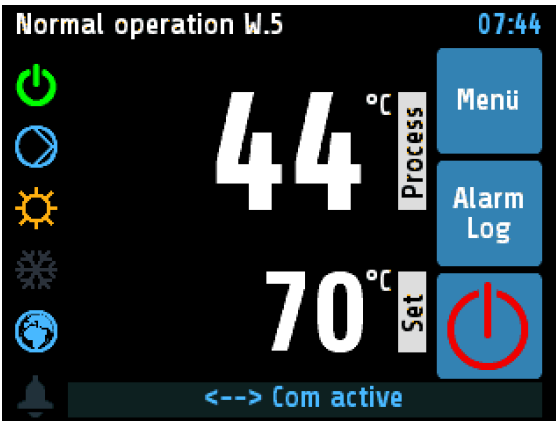

|   |  |
|---|--|
|    | <p>Particular elements can be provided with names.</p> <p>By pressing the number keys „0 ... 9“ the new text can be entered. To set the following letters “ABC1” you have to press the key more times.</p> <p>After one second the character is taken over and the next character can be entered.</p> <p>In order to take over the new text, it must be saved by pressing the “SAVE”- key.</p> |
|    | <p>The entered text is displayed in the blue/white frame.</p>  |
|    | <p>Delete last character.</p>  |
|    | <p>Delete all characters.</p>  |
|   | <p>Key for setting the text. Repeated pressing changes to the next character. Here "A B C 2 Ä"</p>   |
|  | <p>Switching case sensitive. Capital and small letters.</p>  |
|  | <p>Return to previous window</p>   |
|  | <p>Saving of the new text and return to previous window.</p>   |

## 5.1.5 Menu layout











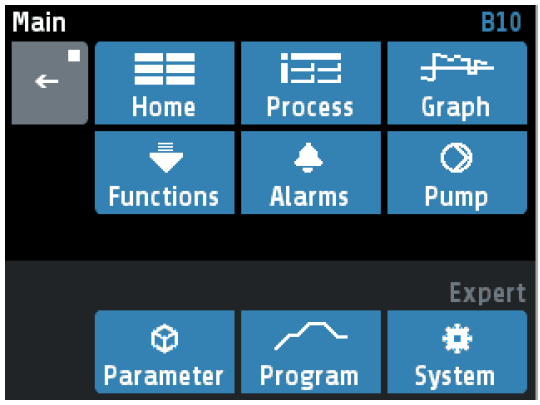

## 5.2 Menus

### 5.2.1 Operating Mode display (Home)





|   |   |
|---|---|
|    |   |
|    | Button „Menu“: Jump to Main Menu  |
|   | Button „Alarm Log“: Jump to the record of events including the temperature alarms   |
|  | Button „on / off“: By means of the button represented on the left hand side the temper device will be switched on / switched off. The colour indicates the actual result of pressing the button:<br><b>Green:</b> The device will be switched <b>on</b><br><b>Red:</b> The device will be switched <b>off</b> . |
|  | Actual temperature value<br>Touch on this section: Jump to setpoint menu  |
|  | Setpoint<br>Touch on this section: Jump to setpoint menu  |
|  | Example of status display <ul style="list-style-type: none"> <li>• device on, controller running</li> <li>• pump is running</li> <li>• heating output is on</li> </ul>  |
|  | Jump to Main Menu   |
|  | Jump to menu „Parameters“   |
|  | Jump to menu „Graph“  |

## 5.2.2 Main Menu

|   |  |
|---|--|
|    | <p>This menu provides the access to the menus and displays</p>   |
|    | <p>Jump to the Operating Mode display.<br/>Shows actual temperature, setpoint, activity of heater and cooler outputs</p>   |
|    | <p>Jump to menu „Process“<br/>Listing of setpoint, actual values of forward circulation temperature and circulation return temperature, output ratio of heater (if leading sign is positive) respectively output ratio of cooler (if leading sign is positive).</p>  |
|   | <p>Jump to menu „Graph“<br/>Diagram of the actual temperature value of the controlled temperature (forward / return)</p>   |
|  | <p>Jump to menu „Functions“</p> <ul style="list-style-type: none"> <li>• Activation of autotune</li> <li>• Activation of cooling down and switch off</li> <li>• Activation of tool (equipment) drainage</li> <li>• Selection of setpoint 1 or setpoint 2</li> <li>• Selection of target of temperature control (supply or return)</li> <li>• Selection of filling mode (manual filling or automatic filling)</li> </ul> <p>Details see 5.2.3</p> |
|  | <p>Jump to menu „Alarms“ (Configuration of event monitoring)<br/>By means of this menu the automatic signalling of events (generally out-of-band signalling) can be determined.<br/>Details see 5.2.6</p>  |
|  | <p>Jump to menu „Pump“<br/>Configuration: Automatic / manual / Cleaning<br/>Details see 5.2.5<br/><i>(prospective feature – currently not available)</i></p>   |
|  | <p>Jump to menu „Parameters“<br/>Details see 5.2.11</p>  |
|  | <p>Jump to menu „Program“<br/>By means of this menu temperature-time-profiles, which are more complex than simple temperature ramps, can be set up.</p>  |

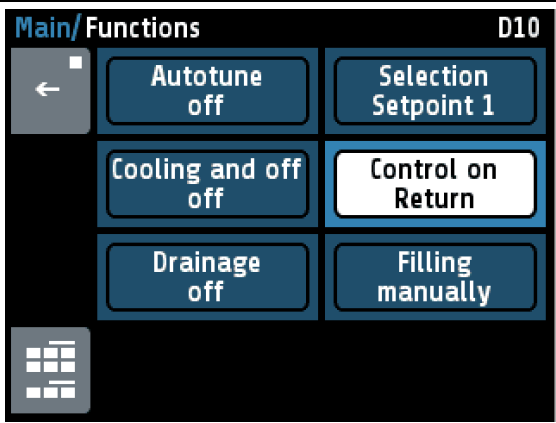
|   |  |
|---|--|
|   | Details see 5.2.10   |
|  | Jump to menu „System“<br>System configurations:<br>date, time, data rate, authorizations<br>Details see 5.2.16 |
|  | Touch < 2 seconds = jump to preceding display<br>Touch > 2 seconds = jump to operating mode display            |

### 5.2.3 Menu „Functions“

|   |   |
|---|---|
|   |   |
|  | Function „Autotune“ please see chapter 5.2.3.1  |
|  | Function „Cooling and off“<br><br><ol style="list-style-type: none"> <li>1. Cooling valve open (-100 %)</li> <li>2. Device will be switched off as soon as temperature is below „cool down temperature“ (see menu 5.2.14.2)</li> </ol>  |
|  | Function „Drainage“ (of tool equipment). This function makes the pump run reverse and opens the drainage valve.<br><ol style="list-style-type: none"> <li>1. Cooling down to „cool down temperature“ (see menu 5.2.14.2)</li> <li>2. Reverse pump direction</li> <li>3. Drainage: Wait delay „drainage time“ (see menu 5.2.14.4)</li> <li>4. Switch off device</li> </ol> <p>The stage „Cooling down“ can be aborted by switching off the device. The stage „Drainage“ cannot be aborted. The device shows error message.</p> |

|  |  |
|--|--|
| <p style="text-align: center;"><b>Filling manually</b></p>     | <p>Function „manual / automatic filling“:</p> <p>If the button „Filling“ is toggled to „automatic“: The filling valve will be activated if the filling level drops below maximum level.</p> <p>If the fluid level is on maximum level (both contacts closed) the pump will be released.<br/>If the fluid level is in between maximum and minimum level the pump remains released.</p> <p>If the fluid level drops below minimal level (tank empty) the pump will be locked.</p> <p>When filling (tank is empty) was activated the pump will not be released until the fluid level exceeds maximum level.</p> <p>If the filling procedure lasts longer than „maximal filling time“ (see menu 5.2.14.3) the alarm output is activated.</p> |
| <p style="text-align: center;"><b>Selection Setpoint 1</b></p> | <p>Selection of setpoint 1 / setpoint 2:</p> <p>Dependent on the current selection the controlled temperature follows setpoint 1 or setpoint 2.</p> <p>If setpoint 2 is selected the operating mode display shows „SP2“ at the headline.</p>   |

### 5.2.3.1 Autotune

|  |                                    |  |
|--|------------------------------------|--|
| <p style="text-align: center;"><b>Autotune off</b></p>   | <p><b>off</b></p> <p><b>on</b></p> | <p>Switches off autotune &lt;Default&gt;</p> <p>Activates autotune</p> |
| <p>The tuning algorithm determines the characteristic values within the controlled process and calculates the valid feedback parameters (P, D, I) and the cycle time. (= 0.3 x D) of a PD/I- controller for a wide section of the range.</p> <p>The autotune mode works during start-up shortly before the setpoint is reached. If activated after the setpoint has already been reached, the temperature will first drop by approx. 5% of the measuring range.</p> <p>The tuning algorithm can be activated at any time by selecting the parameter <b>Autotune = "on"</b>. After having calculated the feedback parameters, the controller will lead the process value to the actual setpoint.</p> <p>Selecting <b>Autotune = "off"</b> will stop the autotune function.</p> <p>Autotune duration &gt; 2 hours: autotune stops with an error message.</p> |                                    |  |

Conditions for starting the autotune algorithm:

- The setpoint must amount to at least 5% of the measurement range
- The sensor must not have a failure.
- The soft start function must not be active

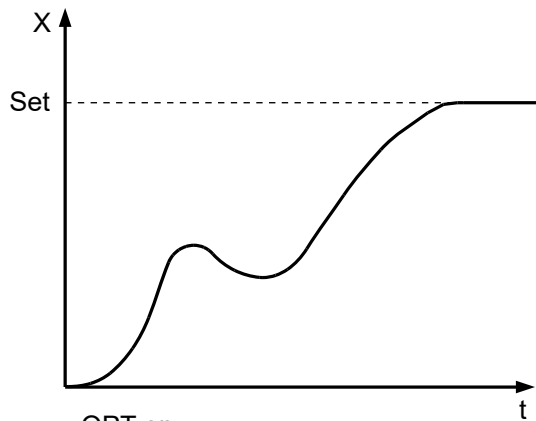

OPT on  
self tune during start-up

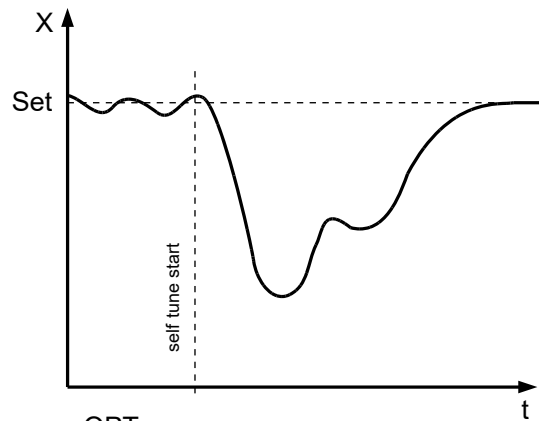

OPT on  
self tune, after the setpoint has  
already been reached

## 5.2.4 Menu „Process“

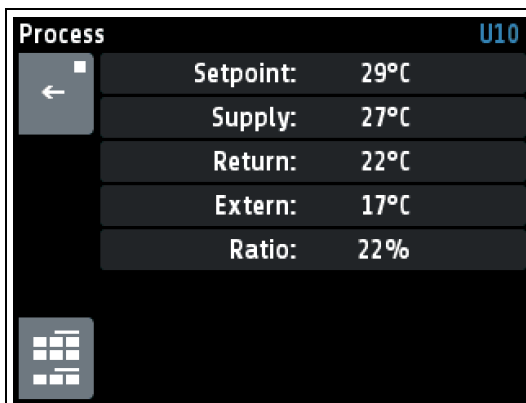

This display shows the fundamental current process values

- Setpoint of the controlled temperature
- Actual value of the controlled temperature
- Actual value of the recirculation
- Actual value of the external temperature
- Actual output ratio
  - positive sign means heating
  - negative sign means cooling

## 5.2.5 Menu „Pump“

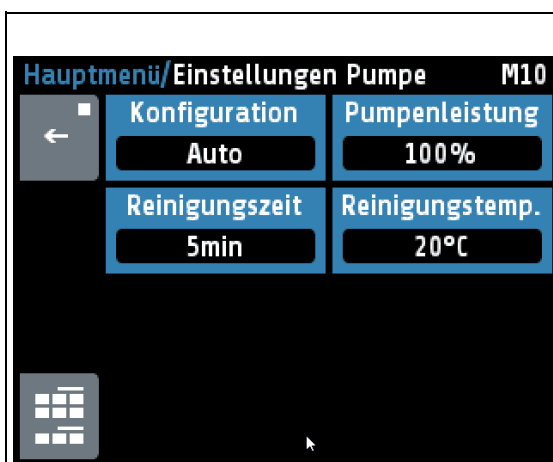

General behaviour:

- The pump works with clockwise rotation, if
- the temper device is in stage „power on“
  - the filling level regulation has released the pump
  - the motor protection is not active

*(The pump configuration menu pictured on the left-hand side is a prospective feature – currently not available)*

## 5.2.6 Menu „Alarms“ (Event Monitoring)

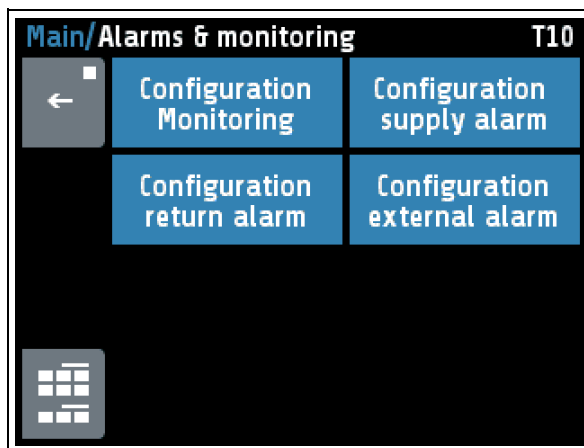

Explanations to the submenus pictured on the left hand side please find as follows in paragraphs 5.2.7 and 5.2.7.1.

## 5.2.7 Menu „Configuration Monitoring“

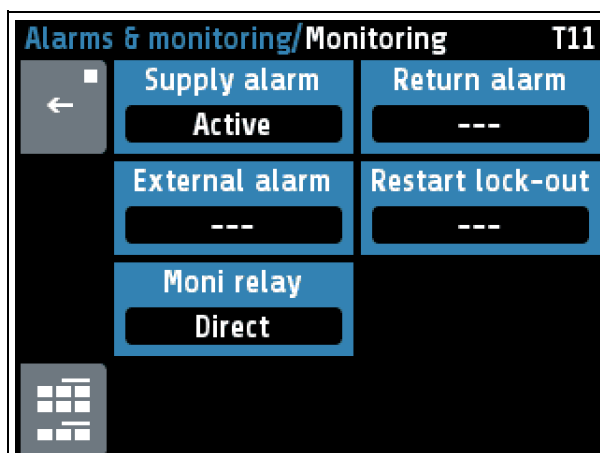

By means of this menu the events can be determined which shall generate signals and messages:

- out-of-band of the supply (forward circulation) temperature
- out-of-band of the supply (forward circulation) temperature
- out-of-band of the supply (forward circulation) temperature
- restart was locked after power-on

Furthermore the switching behaviour of the event monitoring relay can be determined:

- „Direct“: the contacts are closed when event is active
- „Inverse“ the contacts are open when event is active

### 5.2.7.1 Configuration of temperature monitoring

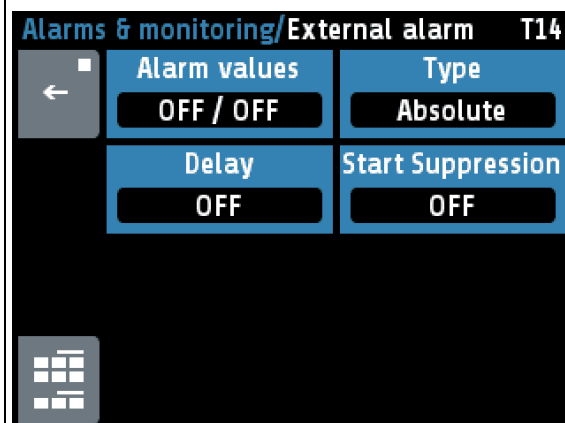
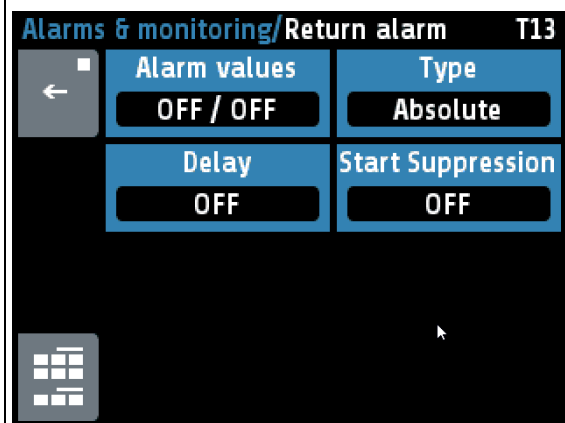
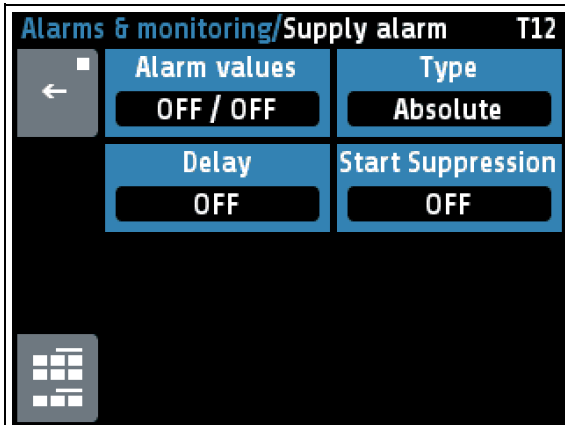





The device provides the monitoring of the following 3 temperature readings:

- supply temperature (temperature of forward circulation)
- return temperature (temperature of return circulation)
- externally measured temperature

The monitoring of the readings listed above can be adjusted as follows:

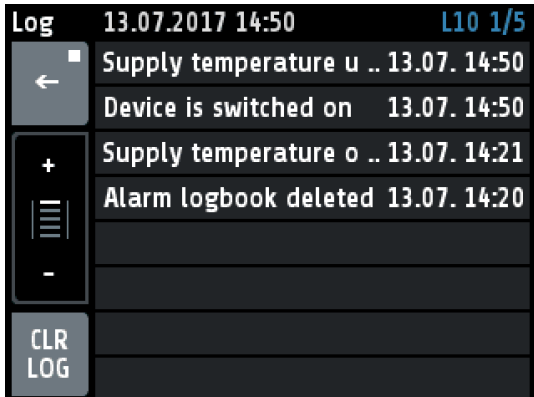
- lower limit value
- upper limit value
- absolute limits: if „absolute“ is activated the limits are not dependent on the set point
- relative limits: if „relative“ is activated the limits are dependent on the set point value. The complete limit values are then figured out, e.g.:  
Upper limit = 80 °C Setpoint + 10 Kelvin (upper limit value) = 90 °C  
Lower limit = 80 °C Setpoint - 10 Kelvin (limit value) = 70 °C
- the alarm signalization is delayed about the entered time (1...8000 s)
- start-up suppression: If activated the ⚡-Alarm is not released until the temperature will have attained once the inner-band sector.



## 5.2.8 Menu „Alarm Log“

|   |   |
|---|---|
|    | <p>This listing saves significant events (Power On, temperature alarms, lock on restarts)</p> <p>The headline shows the current date, time and current page of log listing.</p> <p>If you push and hold a particular entry it will appear in full length.</p> <p>If you push the underpart of the listing the log is scrolled on.</p> <p>The log listing is able to save up to 40 event entries. The most recent entry is listed on page 1/5. If there are more than 40 entries the first input will be deleted.</p> <p>The log listing is stored mains failure safe.</p> |
|   | <p>Jump from operating mode display to the log listing</p>  |
|  | <p>Page up / page down<br/>„+“ preceding page; „-“ next page</p>  |
|  | <p>Jump back to the operating mode display</p>  |
|  | <p>Clear log listing</p>  |

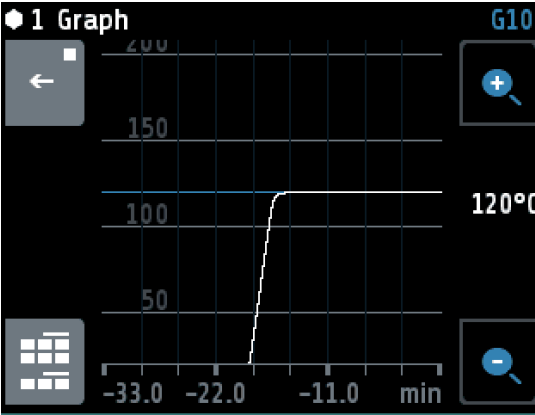

### 5.2.9 Menu „Graph“

This window shows the temperature curve.

In the case of a technical incident the actual process value can still be examined afterwards.

|  |  |
|--|--|
|   | <p>On the right the actual process value is shown, here 250°C.</p> <p>By pressing the zoom keys "+" and "-" the resolution of the temperature axis can be altered.</p> <p>The time axis can be determined by the parameter "Graph sampling time" in the window "System/Settings".</p> <p>Turning off the device causes deletion of the values.</p> |
|   | <p>Hold down &lt; 2 sec. = Return to previous window<br/>Hold down &gt; 2 sec. = Jump to window "Operating Mode Display"</p>   |
|  | <p>Jump to main menu</p>   |

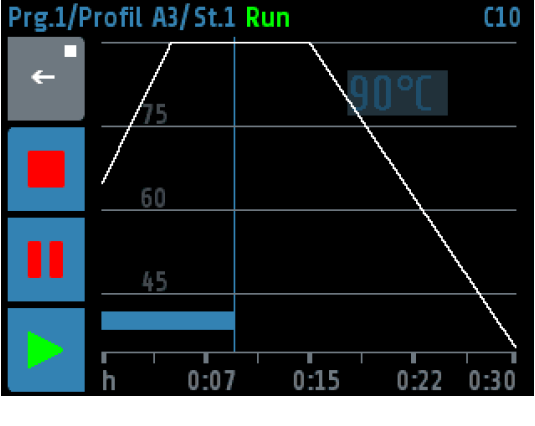
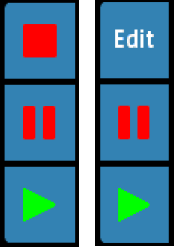
### 5.2.10 Menu „Program“ (Program controller graph)

|   |  |
|---|--|
|  | <p>The header displays the current program, the current step and the status.</p> <p>Right above the graph is the indication of the current program setpoint.</p> <p>At the bottom (x-axis) the time is shown in hours.</p> <p>The elapsed time is displayed as a blue ribbon.</p> <p>The current time is indicated by the thin vertical blue line.</p> |
|  | <p>By means of these keys the program is controlled:</p> <ul style="list-style-type: none"> <li>• Start</li> <li>• Pause</li> <li>• Stop</li> <li>• Edit (only available in mode "Stop")</li> </ul>  |
|  | <p>Hold down &lt; 2 sec. = Return to previous window<br/>Hold down &gt; 2 sec. = Jump to window "Operating Mode Display"</p>   |

### 5.2.10.1 Setting of program controller

The button "Edit" opens the program set up menu:

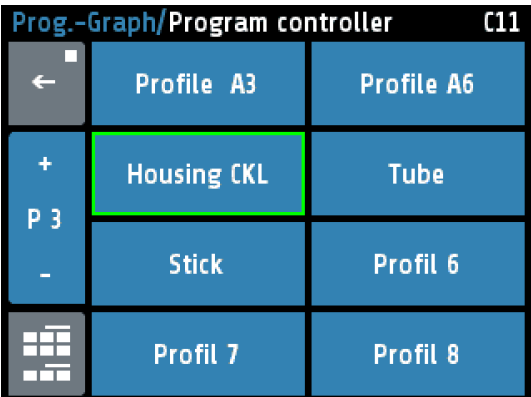
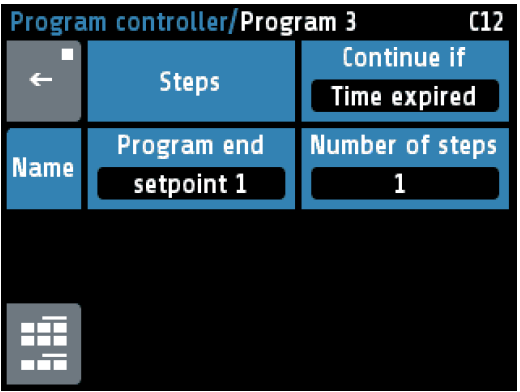
| Select the program   |                      |   |   |
|--|----------------------|---|---|
|   |                      |   | <p>The green frame shows the selected program. Select a other program by pressing + and – keys.</p> <p>Press the respective program button branches to the setup menu of the program.</p> |
| Setting program properties   |                      |   |   |
|  |                      |   |   |
| <b>Continue if</b>   | <b>Time expired</b>  | All steps are executed according to the time grid entered in the appropriate step menu.                               |   |
|  | <b>Temp. reached</b> | After the time has elapsed, the controller switches to the next step. The step setpoint must be reached up to + - 2K. |   |
| <b>Program end</b>   | <b>setpoint 1</b>    | After completion of the last step, the current setpoint is set active. Normally setpoint 1.                           |   |
|  | <b>Last setpoint</b> | After the last step has been completed, the temperature of the last step is further regulated.                        |   |
|  | <b>Repeat</b>        | After the last step has been completed, step 1 is started again.  |   |
| <b>Number of steps</b>   | <b>1 ... 8</b>       | Number of program steps   |   |
| <b>Name</b>  |                      | Entry of the program name   |   |

## Setting step properties

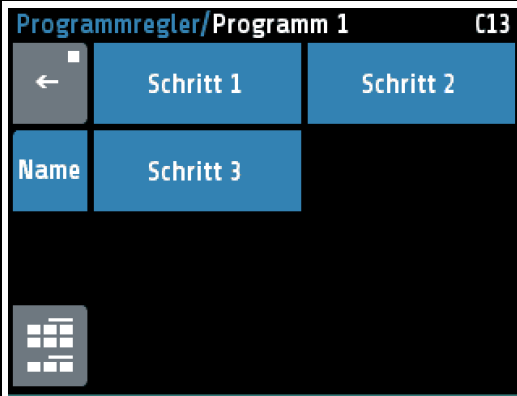

Here the set up menu of the particular step can be invoked.

## Setting the step parameter

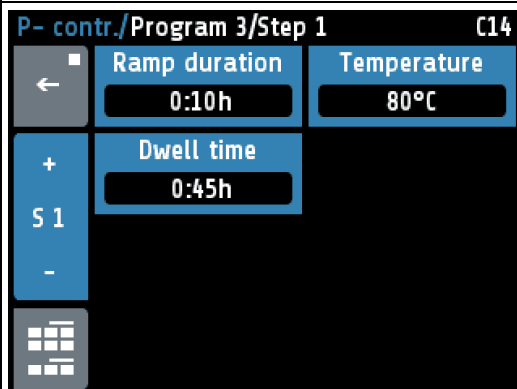

In this figure, the ramp duration, the step temperature and the dwell time can be set for the particular step.

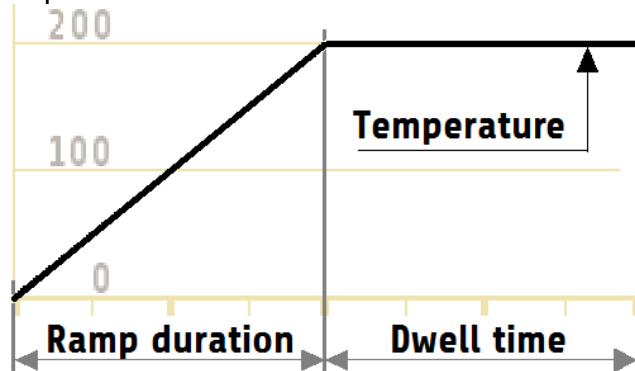

The key S1 + selects the next step.

The key S1 - selects the previous step.

|                      |                 |  |
|----------------------|-----------------|--|
| <b>Ramp duration</b> | 0:00 ... 99:59h | Time setting in which the setpoint shall move from the previous step temperature to the setpoint of the current step. In the first step, the actual value is set as the start setpoint.<br>* If no ramp is desired, set this time to 0: 00h. |
|----------------------|-----------------|--|

|                    |                 |                                      |
|--------------------|-----------------|--------------------------------------|
| <b>Temperature</b> | -100 ... 1600°C | Temperature (setpoint) of this step. |
|--------------------|-----------------|--------------------------------------|

|                   |                 |   |
|-------------------|-----------------|---|
| <b>Dwell time</b> | 0:00 ... 99:59h | Hold time of the current step temperature (step setpoint). The dwell time starts after the end of the ramp duration. If configuration is switched to "temp. reached", this time does not start until target temperature of the particular step is attained. |
|-------------------|-----------------|---|

## Program status in operating mode display (headline)

|                  |              |  |
|------------------|--------------|--|
| Normal operation | ⏪ 2 ▶ 08:47  | Program controller active, Step2 is running. |
| Normal operation | ⏪ 2    08:48 | Program paused or stopped                    |

## 5.2.11 Menu „Parameters“

|  |  |
|--|--|
|  | <p>By means of this menu the configuration of all controller-related parameters can be set up.</p>                           |
|  | <p>Hold down &lt; 2 sec. = Return to previous window<br/>Hold down &gt; 2 sec. = Jump to window "Operating Mode Display"</p> |
|  | <p>Jump to main menu</p>   |

### 5.2.11.1 Tool (equipment) selection

|  |  |
|--|--|
|  | <p>It is possible to store and to select 8 different sets of particular controlling parameters. Affected are the parameters being part of the submenus „Heating“, „Cooling“ and „Configuration Heating / Cooling“.</p> <p>If tool no.4 is selected, e.g., the parameter set no.4 is applied to the temperature controlling. This parameter set is then also accessible for adjusting.</p> <p>If tool no. 2 – no. 8 is selected in the headline of the Operating Mode Display the no. of the current tool parameter set is indicated: „W.4“, e.g.</p> <p>If the standard parameter set (no. 1) is selected there is no tool identification displayed.</p> |
|--|--|

### 5.2.11.2 Setpoint 2

|  |   |
|--|---|
|  | <p>Setting the second setpoint. This value is used for control if the button selection in the "Functions" menu is set to setpoint 2. For example, setpoint 2 can be used to lower the regulated temperature during a break.</p> |
|--|---|

### 5.2.11.3 Configuration Heating / Cooling

|  |   |   |
|--|---|---|
|  | <p><b>Heating</b><br/>&lt;Default&gt;</p> | <p>Two-point controller: "Heating"</p>  |
|  | <p><b>Cooling</b></p>                     | <p>Two-point controller: "Cooling"</p>  |
|  | <p><b>Non-lin. Cooling</b></p>            | <p>Two-point controller: "Cooling" , with non-linear characteristic curve for evaporation cooling</p> |
|  | <p><b>Heating-Cooling</b></p>             | <p>Three-point controller: "Heating-Off-Cooling"</p>  |

## 5.2.12 Control Parameters

|   |   |
|---|---|
| By default the controller operates in PD/I control mode, i.e. controlling without deviation and with nearly no overshoot during start-up.<br>The controlling behaviour can be changed by adjusting the PID parameters listed in paragraphs 5.2.13 and 5.2.14: |   |
| <b>no feed back</b>   | Setting P = off (then D and I are switched off as well) |
| <b>P-controller</b>   | Setting D and I = off                                   |
| <b>PD-controller</b>  | Setting I = off   |
| <b>PI-controller</b>  | Setting D = off   |
| <b>PD/I-controller</b>  | Modified PID-mode (set: P,D,I)                          |

## 5.2.13 Heating Control Parameters

|                                  |  |   |
|----------------------------------|--|---|
| <b>Heating Control parameter</b> |  | This menu is only available if configurations Heating or Heating-Cooling is selected. Depending on the configuration, particular parameters are not visible.  |
| <b>P (xp)</b>                    | <b>OFF, 0.1 ... 400.0K</b><br><Default=10,0> | Proportional range Unit: Kelvin   |
| <b>D (tv)</b>                    | <b>OFF, 1 ... 200s</b><br><Default=30s>      | Derivative time   |
| <b>I (tn)</b>                    | <b>OFF, 1 ... 1000s</b><br><Default=150>     | Reset time  |
| <b>Cycle-time</b>                | <b>0.5 ... 240.0s</b><br><Default=10,0s>     | The switching frequency of the actuator can be determined through the cycle time.<br>In this time interval the controller switches on and off once.<br><u>Voltage outputs for solid state relays (SSR):</u><br>Cycle time: 0,5...10 s<br>Preferred settings for rapid control processes: 0,8s<br><u>Relay outputs:</u> Cycle time: > 10 s<br>The cycle time should be adjusted to a time as long as possible in order to minimize wear of the relay contacts. |
| <b>Max. Output ratio</b>         | <b>0 .. 100%</b><br><Default=100%>           | The limitation of the output ratio is only necessary, if the heating energy supply is grossly over dimensioned compared to the power required.<br>Normally it should be switched off (Setting: 100 %).<br>The limitation becomes effective when the controller's calculated output ratio is greater than the maximum permissible (limited) ratio.<br><b>Warning!</b> The output ratio limiting does not work during autotune.                                 |

|                   |   |   |
|-------------------|---|---|
| <b>Hysteresis</b> | Only adjustable if "(xp)" = off (on-off action, without feedback) |   |
|                   | <b>OFF, 0.1 ... 80.0</b><br><Default=0.1>                         | For measuring range without decimal point |
|                   | <b>OFF, 0.01 ... 8.00</b><br><Default=0.01>                       | For measuring range with decimal point    |
|                   |   |   |

## 5.2.14 Cooling Control Parameters

|                                  |   |  |
|----------------------------------|---|--|
| <b>Cooling Control parameter</b> |   | This menu is only available if configurations Cooling or Heating-Cooling is selected. Depending on the configuration, particular parameters are not visible. |
| <b>P (xp)</b>                    | <b>see 5.2.13</b>   |  |
| <b>D (tv)</b>                    |   |  |
| <b>I (tn)</b>                    |   |  |
| <b>Cycle-time</b>                |   |  |
| <b>Max. Output ratio</b>         |   |  |
| <b>Hysteresis</b>                |   |  |
| <b>Deadband</b>                  | Switching point distance "heating" and "cooling"<br>This parameter is available for "heating and cooling" operations only.<br>(Configuration Heating-Cooling = Heating-Cooling) |  |
|                                  | <b>OFF, 0.1 ... 80.0</b><br><Default=0.1>   | For measuring range without decimal point  |
|                                  | <b>OFF, 0.01 ... 8.00</b><br><Default=0.01>   | For measuring range with decimal point   |

### 5.2.14.1 Ramps

| Ramp  |                             |  |
|---|-----------------------------|--|
| <div style="background-color: #0056b3; color: white; padding: 2px; text-align: center;">1.0K/min / 0.1K/min</div>   |                             |  |
| <p>A programmed ramp is always activated when the setpoint is changed or when the mains supply is switched on. The ramp starts at the actual process value and ends at the pre-selected setpoint. The ramp can be activated for both setpoint 1 and setpoint 2. By programming the second setpoint a setpoint profile can be obtained, accordingly (see example with external contact In_1 (K1) below).</p> |                             |  |
|   |                             |  |
| <b>Ramp rising</b>  | OFF<Default>, 0.1 ... 99,9  | °K/min for measurement range without decimal point |
|   | OFF<Default>, 0.01 ... 9.99 | °K/min for measurement range with decimal point    |
| <b>Ramp falling</b>   | OFF<Default>, 0.1 ... 99,9  | °K/min for measurement range without decimal point |
|   | OFF<Default>, 0.01 ... 9.99 | °K/min for measurement range with decimal point    |

### 5.2.14.2 Cool down temperature

| Cool down temperature  |   |
|--|---|
| <div style="background-color: #0056b3; color: white; padding: 2px; text-align: center;">50°C</div> | Function „cooling and off“ described in 5.2.3 will be shut off when this temperature is attained. |

### 5.2.14.3 Maximal filling time

| Maximal Filling time   |  |
|--|--|
| <div style="background-color: #0056b3; color: white; padding: 2px; text-align: center;">120s</div> | If the filling process lasts longer than the maximal filling time the alarm signal (monitoring signal) is activated. |

### 5.2.14.4 Drainage time

| Drainage time   |   |
|---|---|
| <div style="background-color: #0056b3; color: white; padding: 2px; text-align: center;">20s</div> | This time is applied to the function „Drainage“ described in 5.2.3. |

## 5.2.15 Offsets and setpoint limits

|                                    |  |
|------------------------------------|--|
| <b>Offsets and setpoint limits</b> | <p>By means of this menu the following parameters are adjustable:</p> <ul style="list-style-type: none"> <li>• minimal setpoint supported by menu</li> <li>• maximal setpoint supported by menu</li> <li>• offset to be added to supply (forward circulation) temperature reading</li> <li>• offset to be added to return (return circulation) temperature reading</li> <li>• offset to be added to externally measured temperature reading</li> </ul> |
|------------------------------------|--|

## 5.2.16 Menu „System“

|  |  |
|--|--|
|  | <p>This menu serves as access to general settings and information listed in the following:</p> |
|--|--|

## 5.2.17 Menu for Common Settings (General Settings)

|                        |                                      |  |
|------------------------|--------------------------------------|--|
| <b>Menu „Common“</b>   |                                      |  |
| <b>System/Settings</b> |                                      | <b>S11</b>                             |
| ←                      | <b>Language</b><br>English           | <b>Authorisation</b><br>All parameters |
|                        | <b>Time</b><br>19h:04min             | <b>Day / Month</b><br>14 / 7           |
|                        | <b>Year</b><br>2017                  | <b>Sample rate</b><br>10 s             |
|                        | <b>Restart lock-out</b><br>off       |  |
|                        |                                      |  |
| <b>Language</b>        | <b>Deutsch (German)</b><br><Default> | German                                 |
|                        | <b>English (English)</b>             | English                                |
| <b>Authorisation</b>   | <b>All Parameter</b>                 | All parameters adjustable              |

|   |   |   |
|---|---|---|
| <b>(LOC)</b>  | <b>adjustable</b><br><Default>  |   |
|   | <b>Setp. and ramps adjustable</b>   | Setpoints, alarm values and ramps are adjustable.<br>All other parameters are locked.   |
|   | <b>Only setpoint 1 adjustable</b>   | All other parameters are locked   |
|   | <b>All parameters locked</b>  | No parameter is adjustable  |
|   | <b>Change Lock code</b>   | Here the code (start value = 0000) can be changed to a different value.   |
| <p>The previous code is requested before setting the new code. The new Code has to be entered twice. The parameters that have been locked can be displayed but not changed. This parameter cannot be changed if the logic input In_2 is active, or the lock code is not known. The value of the factory setting is &lt;Default = 0000&gt;</p> |   |   |
| <b>Time</b>   | <b>Hours</b>  | Number value 0 ... 23   |
|   | <b>Minutes</b>  | Number value 0 ... 59   |
| <b>Day / Month</b>  | <b>Day</b>  | Number value 1 ... 31   |
|   | <b>Month</b>  | Number value 1 ... 12   |
| <b>Year</b>   | <b>2000 ... 2150</b>  | Adjustment of calendar year   |
| <b>Sample rate</b><br><br>Scanning time for recorder function   | <p>Time interval between the current measurements of two successive samples. In brackets the complete time interval as shown on display:</p> <p><b>2,5 s (Total time: 8,2 Min)</b><br/> <b>5 s (Total time: 16,5 Min)</b><br/> <b>10 s (Total time: 33 Min) &lt;Default&gt;</b><br/> <b>30 s (Total time: 99 Min)</b><br/> <b>1 Min. (Total time: 3,3 h)</b><br/> <b>5 Min. (Total time: 16,5 h)</b><br/> <b>10 Min.(Total time: 33 h)</b></p> <p>A maximum of 198 temperature points can be saved.</p> |   |
| <b>Restart lock-out</b>   | <b>OFF</b><br><Default>   | No function   |
|   | <b>On</b>   | After power-on the temperature controlling is switched of and a message is displayed. Switch on must be acknowledged. After acknowledgement the controlling will be started. In addition the alarm "Restart lock-out" will be set and can be handled in the monitoring. |

## 5.2.18 Menus Fieldbus / USB / LAN

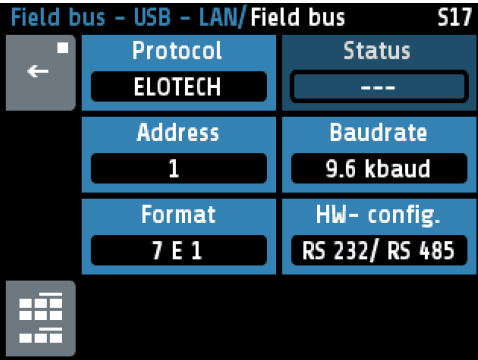
| Menu "Fieldbus"   |                                   | Depending to the installed fieldbus module parameters are displayed or hidden.   |
|---|-----------------------------------|--|
|  |                                   |  |
| <b>Protocol</b>   | off                               | No protocol selected   |
|   | <b>Elotech</b>                    | <SERIAL> ELOTECH-Standard-protocol   |
|   | <b>Modbus</b>                     | <SERIAL> Modbus-RTU-protocol   |
|   | <b>Arburg 1</b>                   | <SERIAL> Hot runner  |
|   | <b>Arburg 2</b>                   |  |
|   | <b>Arburg 3</b>                   | <SERIAL> Protocol for temperature control systems  |
|   | <b>Profibus DP</b>                | <PROFIBUS> Profibus DP   |
| <b>Status</b>   | ---                               | <SERIAL> No data communication   |
| Display only  | <b>Data Exchange</b>              | <SERIAL> Data communication is active<br><PROFIBUS> Data-Exchange-Mode   |
|   | <b>Wait Param</b>                 | <PROFIBUS> Controller waits for configuration / parametrisation  |
|   | <b>No connection</b>              | <PROFIBUS> No master connected / Master not active   |
| <b>Baudrate</b><br><SERIAL>   | <b>1.2 kBaud</b>                  | 1.200 Bit/s  |
|   | <b>2.4 kBaud</b>                  | 2.400 Bit/s  |
|   | <b>4.8 kBaud</b>                  | 4.800 Bit/s  |
|   | <b>9.6 kBaud</b>                  | 9.600 Bit/s  |
|   | <b>19.2 kBaud &lt;Default&gt;</b> | 19.200 Bit/s   |
|   | <b>38.4 kBaud</b>                 | 38.400 Bit/s   |
| <b>Baudrate</b><br><PROFIBUS>   | Display only                      | 45,5 kBaud – 12Mbaud (forced by the master)<br>Not detected = no master connected  |
| <b>Address</b>  | 1 ... 255                         | 1<Default> ... 255 (ELOTECH-Standard)<br>1<Default> ... 247 (Modbus-RTU-Protocol)<br>1<Default> ... 32 (Arburg-Protocols)<br>2<Default> ... 125 (Profibus)<br>At this address a master communicates with the controller. Each controller needs a unique address. |
| <b>Format</b>   | <b>7 E 1 &lt;Default&gt;</b>      | 7 Data bits, 1 Stop bit, Parity Even   |
|   | <b>7 0 1</b>                      | 7 Data bits, 1 Stop bit, Parity Odd  |
|   | <b>7 E 2</b>                      | 7 Data bits, 2 Stop bits, Parity Even  |
|   | <b>7 0 2</b>                      | 7 Data bits, 2 Stop bits, Parity Odd   |
|   | <b>7 N 2</b>                      | 7 Data bits, 2 Stop bits, Parity None  |
|   | <b>8 E 1</b>                      | 8 Data bits, 1 Stop bit, Parity Even   |
|   | <b>8 0 1</b>                      | 8 Data bits, 1 Stop bit, Parity Odd  |
| <SERIAL>  | <b>8 N 1</b>                      | 8 Data bits, 1 Stop bit, Parity None   |
|   | <b>8 N 2</b>                      | 8 Data bits, 2 Stop bits, Parity None  |

|                              |   |  |
|------------------------------|---|--|
| <b>HW-config</b><br><SERIAL> | The serial fieldbus module has three integrated interfaces.<br>Select here the desired interface: |  |
|                              | <b>RS232/RS485</b>  | Signals see connection diagram.                            |
|                              | <b>TTY</b>  | Signals see connection diagram.                            |
|                              |   |  |
| <b>Remote</b><br><PROFIBUS>  | <b>On</b>   | Profibus can read and write.<br>Local operation is locked. |
|                              | <b>Off</b> <Default>  | Profibus can read only. Local operation is permitted.      |

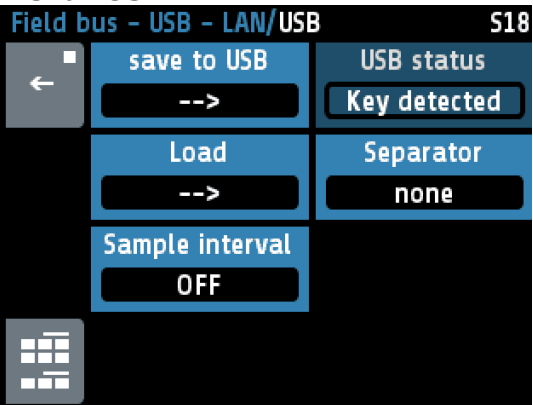
|   |  |   |
|---|--|---|
| <b>Menu "USB"</b><br>  |  | Save controller data on an USB-Stick. (USB-flash drive)<br><br>The data is stored as a text file in an adjustable CSV-format.<br><br>The USB-flash-drive must be formatted with FAT. (FAT16/ FAT32) The file name contains the last 5 digits "xxxxx" of the MAC-ID. |
| <b>Save to USB</b>  | <b>All parameters</b>                    | Save all parameters<br>Generates the file -> LogParaxxxxx.txt and LogPara.bin   |
|   | <b>Al. Logbook</b>                       | Save the entries of the Alarm Logbook.<br>Generates the file -> LogBookxxxxx.txt  |
|   | <b>Graph</b>                             | Save the readings of the graph<br>Generates the file -> LogGraphxxxxx.txt   |
| <b>USB status</b>   | - - -                                    | Display of the USB-status: no stick detected.   |
|   | <b>Key detected</b>                      | USB-stick detected:<br>Files can be saved or loaded from the USB flash drive.   |
| <b>Load</b>   | <b>Load all Parameters</b>               | Loading a previously saved parameter set. The file "LogPara.bin" must exist on the USB flash drive.   |
| <b>Separator</b>  | <b>none</b> <Default>                    | Delimiter symbol between single data sets:<br>Spaces  |
|   | <b>comma</b>                             | ,   |
|   | <b>semicolon</b>                         | ;   |
|   | <b>colon</b>                             | :   |
|   | <b>tabulator</b>                         | <TAB>   |
| <b>Sample-Interval</b>  | <b>OFF;</b> <Default><br><b>5...720s</b> | Cycle time for writing an output line with time stamp on the USB stick. The values setpoint, actual value, output ratio and current actual value are written out.   |
| <p>If the parameter "Log interval" is set to a numerical value, so a file named "LogR4000_xxxxx_YYYY_MM_DD.txt" is generated on the USB stick. "xxxxx" the last 5 digits of the MAC-ID. YYYY, MM and DD mean the year, month, day. After a change of date a new file is created.</p> <p>With the included names MAC-ID "xxxxx", the files can be assigned to different R4000 controllers.</p> <p>Each "Log interval" time a new row is added. The line includes a timestamp, setpoint, the actual value, the output ratio and the actual current value.</p> |  |   |

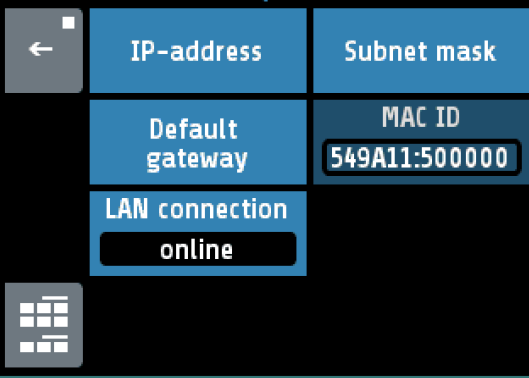
|   |                         |  |
|---|-------------------------|--|
| <b>Menu "LAN"</b><br>Field bus - USB - LAN/LAN <span style="float: right;">519</span> |                         | Ethernet interface for connection to <ul style="list-style-type: none"> <li>• Web browser</li> <li>• configuration tool EloVision 3</li> <li>• PLC via MODBUS-TCP</li> </ul>   |
|      |                         | Connect the device RS4100 to the LAN.<br><br>The static IP address must be set to an address which is not allocated to another device being part of the same LAN.<br><br>Please adjust the subnet mask as well and the default gateway according to the requirements of the LAN.<br><br>In order to operate the device via web browser please enter the chosen static IP address into the address field of the web browser, for example: „192.168.100.100“ |
| <b>Static IP address</b>  |                         | <b>192</b> . 168 . 100 . 100 Part 1 <Default>  |
|   |                         | 192 . <b>168</b> . 100 . 100 Part 2 <Default>  |
|   |                         | 192 . 168 . <b>100</b> . 100 Part 3 <Default>  |
|   |                         | 192 . 168 . 100 . <b>100</b> Part 4 <Default>  |
| <b>Subnet mask</b>  |                         |  |
| <b>Subnet mask 1</b>  |                         | <b>255</b> . 255 . 255 . 0 Part 1 <Default>  |
| <b>Subnet mask 2</b>  |                         | 255 . <b>255</b> . 255 . 0 Part 2 <Default>  |
| <b>Subnet mask 3</b>  |                         | 255 . 255 . <b>255</b> . 0 Part 3 <Default>  |
| <b>Subnet mask 4</b>  |                         | 255 . 255 . 255 . <b>0</b> Part 4 <Default>  |
| <b>Default gateway</b>  |                         |  |
| <b>def.-gateway 1</b>   |                         | <b>192</b> . 168 . 100 . 1 Part 1 <Default>  |
| <b>def.-gateway 2</b>   |                         | 192 . <b>168</b> . 100 . 1 Part 2 <Default>  |
| <b>def.-gateway 3</b>   |                         | 192 . 168 . <b>100</b> . 1 Part 3 <Default>  |
| <b>def.-gateway 4</b>   |                         | 192 . 168 . 100 . <b>1</b> Part 4 <Default>  |
| <b>MAC ID</b>   | <b>549A11:5xxxxx</b>    | Display of the MAC-ID: 54:9A:11:5x:xx:xx   |
| <b>LAN connection</b>   | <b>online / offline</b> | For connection to other devices this parameter must be set to "online"   |

## 5.2.19 Menu About

| Menu "About"  |   |
|---|---|
|  |   |
| <b>Firmware</b>   | Displays the current firmware version   |
| <b>Language version</b>   | Displays the current language version   |
| <b>Firmware update</b>  | <p>Start the firmware update by selecting the button "Start Update" and confirm with SAVE. A confirmation prompt opens. If this window is confirmed with YES, the unit turns into the loader mode.</p> <p>When the loader mode is accidentally turned on, you can switch back by a mains reset into the existing user program.</p> <p>If an update should be performed, a USB flash drive must be plugged in with the new firmware. After a short time, the firmware folder appears in the line "Folder". E.g. „EL4100.01_V20xx_xx.ELO“.</p> <p>Now you can start the loading process by touching the touch screen.<br/>The controller must not be disconnected from the power supply until the download is complete!<br/>After finished loading the new user program is started by a power interruption.</p> |
| <b>Factory setting</b>  | Reset to factory delivery status. With the help of this parameter, all settings are deleted and reset to the delivery status. Choose "Reset", then press "SAVE".  |
| <b>Type R4100-0x-x-000-0x-5</b>   | Type key of the controller  |
| <b>www.elotech.de<br/>info@elotech.de</b>   | Homepage and E-mail address of the manufacturer.  |

## 6 Error Messages

| <b>Error message</b>                          | <b>Cause</b>   | <b>Possible remedy</b>  |
|---|--|---|
| At actual process value maximum value flashes | Top range end has been exceeded, sensor defect                           | Check sensor and cable  |
| At actual process value minimum value flashes | Bottom range end has been exceeded, sensor defect                        | Check sensor cable<br>Check process value offset<br>TC connected with inverted polarity                                   |
| REMOTE:<br>Parameter locked                   | Adjusting of parameters is not allowed. Device is controlled by fieldbus | Profibus: The parameter "Remote" in the menu Field bus is set to "on".<br><br>The configuration-tool EloVision is active. |
| Field bus module unavailable                  |  | The controller is not fitted with the correct hardware for the selected protocol.   |
| DfErr   | Text display error   | Please send the controller back to the manufacturer.  |
| ERR0  | System error   | Please send the controller back to the manufacturer.  |
| ERR8  | System error   | Quit error message.<br>Check the parameters. If the error is still there, send the controller back to the manufacturer.   |

## 7 Technical Data

|                                  |   |  |
|----------------------------------|---|--|
| Input Pt100 / RTD<br>-30...400°C | PT100-1 and PT100-2: 2- wire connection<br>PT100-3 : 3- wire connection<br>Built-in protection against sensor breakage and short circuit<br>Sensor current: < 1 mA<br>Calibration accuracy: ... < 0,2 % Linear error: < 0,2 %<br>Influence of the ambient temperature: < 0,01 % / K |  |
| Logic input                      | Internal resistance > 22k-Ohm<br>Level 0 < 2V<br>Level 1 > 9V; max 30V  |  |
| Logic outputs                    | Bist. voltage, 0/24 V DC, max. 500 mA, short-circuit proof  |  |
| Relay output                     | Relay changeover contact; max. 250V AC, max. 3A, resistive load   |  |
| Continuous outputs               | 0...20 mA maximal load 300 Ohm; 0...10V minimal Load 5kOhm.<br>Automatic switching, depending on connected load.  |  |
| Hybrid Output                    | Optional plug-in module<br>tri-phase contacts, two phases are operated by controller.<br>max. 440V AC; max. 13A; max. 9kW total power<br><b>Please note: These outputs have to be protected by separate 16 Ampere fuses of type FF (very fast acting).</b>                          |  |
| Fieldbus                         | Optional plug-in module:<br>- Serial: RS232, RS485, TTY (20mA)<br>- Profibus DP, according to EN 50170<br>All variants are equipped with optical insulation.  |  |
| Ethernet                         | Modbus TCP  |  |
| USB                              | Host for USB-Stick; max. 100mA  |  |
| Supply voltage                   | 24 V DC, +/-25 %  |  |
| Power consumption                | appr. 6W + Power of logic outputs   |  |
| LCD-Display                      | 8,8 cm (3,5") RGB-display with LED-backlight.<br>320 x 240 pixel with resistive Touch-Panel   |  |
| Data protection                  | EARAM, Semiconductor storage<br>When using a Fieldbus interface please note: Permissible writing operations per parameter must not exceed 1 000 000.  |  |
| Real time clock                  | Backup battery: Lithium CR2032  |  |
| Housing R4100-C                  | Type  | Unsealed frame to be covered by a front film |
|                                  | Format  | Ca. 90 x 90 mm; Mounting depth: ca.60 mm     |
|                                  | display cut-out   | 78 +0,5 mm x 70 +0,5 mm                      |
|                                  | Material:   | Sheet steel and Makrolon UL 94-V1            |
|                                  | Protection class  | IP 10 (DIN 40050), Front side: IP 00         |
| Housing R4100-M                  | Type  | to be mounted on cap rail TS35/7,5           |
|                                  | Format  | Width: ca. 130 mm                            |
|                                  |   | Length: ca. 90 mm                            |
| Height: ca. 70 mm                |   |  |

|                                  |  |  |
|----------------------------------|--|--|
|                                  | Material:  | PVC  |
|                                  | Protection class   | IP 10 (DIN 40050), Front side: IP 00   |
| Weight R4100-C                   | Approximately 250 g, depending on actual model   |  |
| Weight R4100-M                   | Approximately 250 g, depending on actual model   |  |
| Connectors                       | Service-Interface: Ethernet RJ45<br>USB-Interface: Type A<br>Profibus: SUB-D 9<br>Others: Screw terminals, Protection mode IP 10 (DIN 40050)<br>Insulation class C |  |
| Permissible operating conditions | Operating temperature:   | 0...50°C / 32...122°F  |
|                                  | Storage temperature:   | -30...70°C / -22...158°F   |
|                                  | Climate class:   | KWF DIN 40040; equivalent to annual average<br>max. 75% rel. humidity, no condensation |
| Harmonized standards             | EN 61326-1:2013 / EN 61000-3-2:2006+A1:2009+A2:2009<br>EN 61000-3-3:1995+A1:2001+A2:2005<br>Electrical safety: EN 61010-1  |  |

Subject to changes without notification

